

U.L. LISTED CANADIAN LISTED CSFM: 7300-1418:100

GENERAL DESCRIPTION:

S/N _____

The The Cookson Company Firefly II-MV time delay release devices are designed for use on rolling doors. All models are normally energized Fail-Safe Releasing Devices incorporating state of the art electronic control circuitry. The Firefly II-MV series release devices respond to emergency conditions generated by manual or automatic normally closed initiating devices and shall be used in conjunction with a temperature fuse link system.

The Firefly II-MV series release device features include; world power source capability allowing the same unit to be used on 24VDC, 24VAC or 120VAC 50 or 60HZ., separate adjustable time delays for alarm and power loss, motor voltage sensing, form-C relay output, proximity/door edge input and trouble diagnostic capabilities. **Models FFII and FFIIIB can be wired for two or four wire configuration. *Check model label on unit to be installed to verify applicable features.**

CAUTION: Review all installation instructions, procedures, cautions and warnings contained within this manual prior to installing and/or servicing this product. As with all releasing device systems, maximum fire protection is provided when installed in accordance with factory specifications and used with fuse link systems.

Fail-safe operation can only be provided with input power applied. DO NOT install this unit without fuse links.

TEST SYSTEM AT LEAST ONCE EVERY 90 DAYS TO ASSURE PROPER OPERATION.

Installation and testing to factory specifications shall be performed by factory authorized personnel for proper operation in accordance with all of the latest National Fire Protection Association (NFPA), Underwriters Laboratories (UL), National Electrical Code (NEC), local, state, county, district and/or other applicable building and fire standards, guidelines, regulations and codes including, but not limited to, all appendices and amendments and the requirements of the local authority having jurisdiction (AHJ).



INSTALLATION INSTRUCTIONS - To be performed by factory authorized personnel only.

The following installation procedures must be followed to assure performance of the release device to factory standards.

SECTION A. MOUNTING PROCEDURE (Figure 1)

1. The release device shall be mounted on a vertical surface with chain end link exiting side of enclosure as illustrated in figure 1. The unit may be rotated 90 degrees CW for a direct vertical pull.
2. Release device enclosure shall be mounted with minimum #10 size fastening screws or bolts for securing to structures other than masonry. Masonry applications shall utilize 1/4" or greater anchors or studs as required to ensure proper mounting strength.
3. Release device and associated hardware [sash chain or 1/16 cable, eyebolts, fuse links (**DO NOT install this unit without fuse links**), turnbuckles] shall be installed as per door manufacturers recommendations (figure 1 typical installation configuration). Note should be taken that the end link direction of pull is perpendicular to the enclosure side. An eyebolt installed at a distance of 18 to 24 inches from the release device should adequately redirect sash chain pull as illustrated in figure 1.
4. Complete hardware installation by connecting fuse links, sash chain, S-hooks and turnbuckles as required. Push reset lever in direction of arrow on label to allow insertion of end link through release device side opening. Push end link completely in and release reset lever to latch end link. Remove sash chain slack by adjusting turnbuckle.
Do Not exceed 40 lbs. maximum pull rating on release device.

SECTION B. Smoke Detectors.

When installing smoke detectors with this unit refer to NFPA 72-1993 and NFPA 80, for instructions concerning proper placement and detection coverage. **End of line devices (relays) must be installed in accordance with U.L. 864. See electrical connections figure 4.** Verify detector placement with Final AHJ.

SECTION C. ELECTRICAL CONNECTIONS - All models (Figure 4 - 4 wire operation, figure 4A - 2 wire operation)

Installation of all wiring and connections shall be performed in accordance with, but not limited to, the latest **NFPA, U.L. and N.E.C.** standards. In addition, all installations subject to Canadian standards shall be performed in accordance with the **Canadian Electrical Code, Part I**, with respect to wiring material, wiring gauge related to power capacity requirements and circuit length and wiring methods.

The following wiring instructions can configure the unit for independent delay on alarm and power loss using four wires or a single adjustable delay using only two wires. Use steps 1-2-3-4 for 4 wire operation. *Use 1-2-3 for 2 wire operation.

See Figure 4, page 3A for 4 wire dual delay wiring and Figure 4A, page 3B for 2 wire single delay wiring

1. Turn off power supply before beginning.
2. Verify voltage rating of release device to power source being utilized.
3. Connect 24 volt power source inputs to MV circuit board, screws 1 & 2. On 24VDC units **observe proper polarity** by placing positive (+) wire to screw 1. 120 VAC use TB3. TB3 screw 3 shall be utilized for earth ground where applicable.
4. **Normally closed initiating devices** (smoke detectors)- remove jumper from screws 1 & 2 (Alarm loop will not function if jumper is not removed). Connect wiring from N/C initiating device alarm loop to TB1 screws 1 & 2 (see NFPA 72-1993 and NFPA 80 for proper placement of smoke detectors). **NOTE:** Alarm loops cannot be series or parallel connected between TB1 of multiple release devices.

OPTIONS: FFIIB-MV only.

***Close Limit Detection (Lower limit/Proximity switch)** -This option interfaces to electrical contact type lower limit sensing devices and/or magnetic proximity type switches. If the electrical contact has toggled states from its N/O condition to a closed condition (TB1-5&6) indicating the door edge has made contact with desired down position, the release device logic will prevent the solenoid from energizing on alarm, thereby eliminating any damage which may result to the door from the release device attempting to close the already lowered door. **This option only works as long as power is available to unit. Fail-safe operation shall be maintained under all operating conditions.**

* TYPICAL INSTALLATION

FIGURE 1

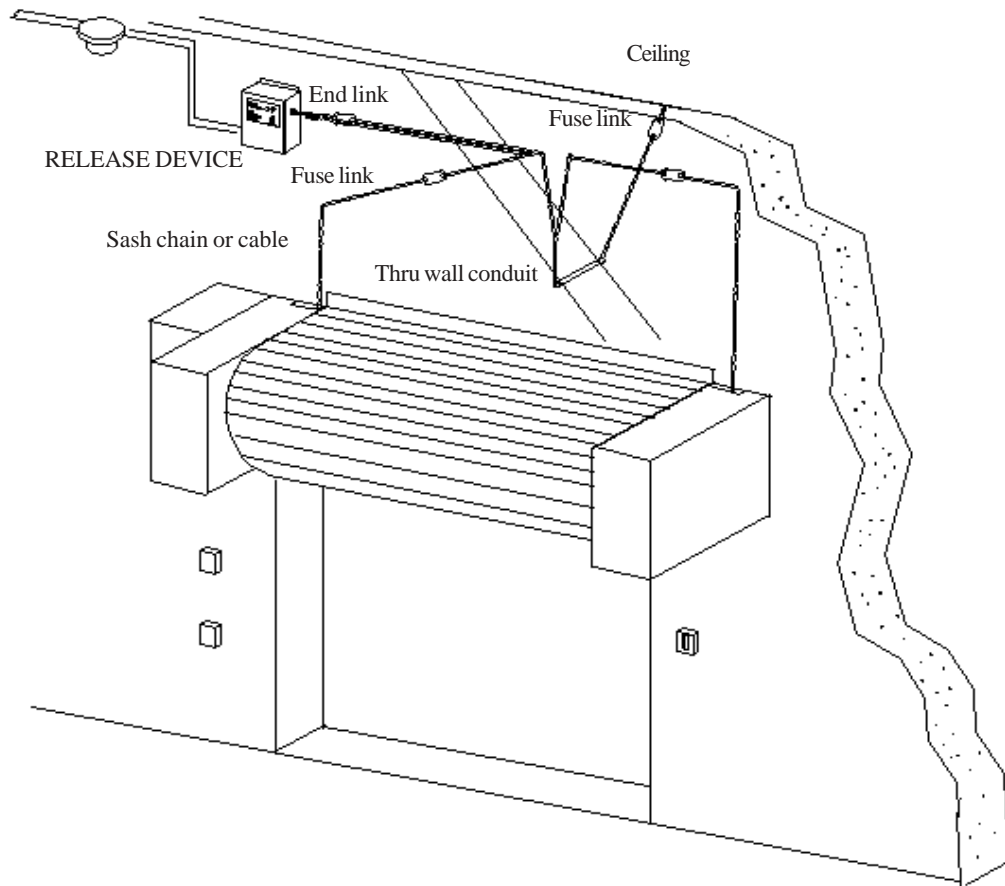

* Actual configuration may differ. This unit may be rotated 90 degrees CW for a vertical pull. See door manufacturer recommendations and NFPA 80 for use of this product with specific door. **DO NOT** install this unit without fuse links.

INSIDE VIEW FFII-MV

FIGURE 2

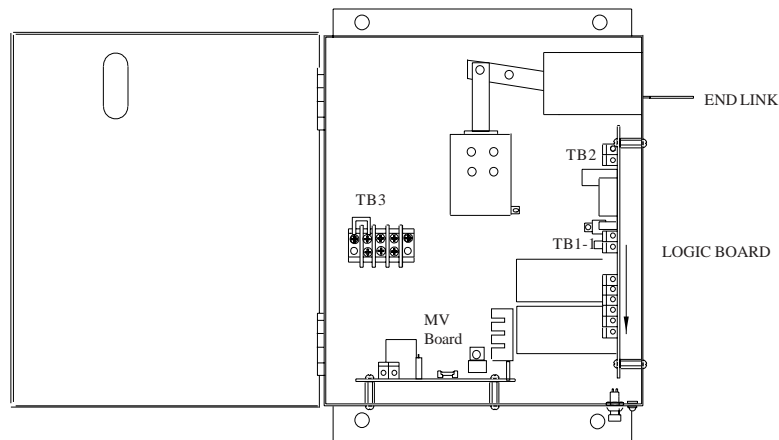

TROUBLE RELAY (TB1-8,9&10) The trouble relay toggles immediately upon a power loss or alarm condition and may be used for turning on signalling appliances (horns, strobes, etc.) or other external signalling functions requiring a dry contact open or closure. Figure 4 illustrates contacts with no power to unit. With power applied TB1-9&10 are closed and toggle in alarm and power loss.

Optional wiring - Verify that all operating voltage is off before continuing.

5. **Normally open lower limit/proximity switch (closes in down limit).** Connect wiring from *Aux. electrical loop to TB1 screws 5 & 6. Leave jumper in TB1-6&7. Remove jumper & use TB1-6&7 for a N/C which opens in down limit.

6. Trouble Relay - Connect wiring to common TB1-9 and either N/O contact TB1-10 or N/C contact TB1-8.

*** Note: Electrical loop must be provided as dry contacts and may not be used in conjunction with the simultaneous switching of a motor control or any other voltage through the same contacts. Connections of this type will result in immediate damage to the release device.**

Verify all connections made within unit. Close hinged cover and secure screw on lid after all connections are made.

DO NOT LEAVE COVER OPEN AFTER CONNECTIONS ARE MADE!

Firefly II-MV SERIES RELEASE DEVICE ELECTRICAL AND MECHANICAL CHARACTERISTICS

OPERATING VOLTAGES

MODEL

FFII-MV	24VDC +10% /-15%	24VAC +10% /-15%	120VAC +10% /-15%
FFIIB-MV	24VDC +10% /-15%	24VAC +10% /-15%	120VAC +10% /-15%

CURRENT REQUIREMENTS

	----- Operating Voltage -----		
	24VDC	24VAC	120VAC
Current rating	SUPERVISORY/ALARM	SUPERVISORY/ALARM	SUPERVISORY/ALARM
Model			
FFII-MV	.025A/.045A	.075A/.130A	.300A/.650A
FFIIB-MV	.025A/.045A	.075A/.130A	.300A/.650A

INITIATING LOOPS -

CAUTION: All initiating devices shall be dry contact type only

- Maximum loop resistance: 100 Ohms
- Maximum current: Not to exceed .002A
- Maximum voltage: 15Vdc

FORM C OUTPUT (MAXIMUM CONTACT RATING)

2A/15Vdc 30 Watt DC Resistive Load Only

FUSE RATINGS

Model FFII PC Board - 0.75 AMP @250V
2AG FAST ACTING TYPE

MVPC BOARD

- F1 2A @ 250v, 2AG Fast Acting, high voltage input
- F2 1A @ 250v, 2AG Fast Acting, low voltage input
- F3 1A @ 250v, 2AG Fast Acting, low voltage output

MECHANICAL- LOAD RATING

Support and release: 40LB. MAXIMUM

DIMENSIONS

7 1/2" x 8 " x 4" (H x W x D)

ELECTRICAL CONNECTIONS (TYPICAL) - FIGURE 4

FOUR WIRE- INDEPENDENT ALARM & POWER LOSS DELAYS

Refer to Section C - Electrical Connections pages 2&3 for complete FFII wiring instructions. Reference all footnotes below for additional installation information.

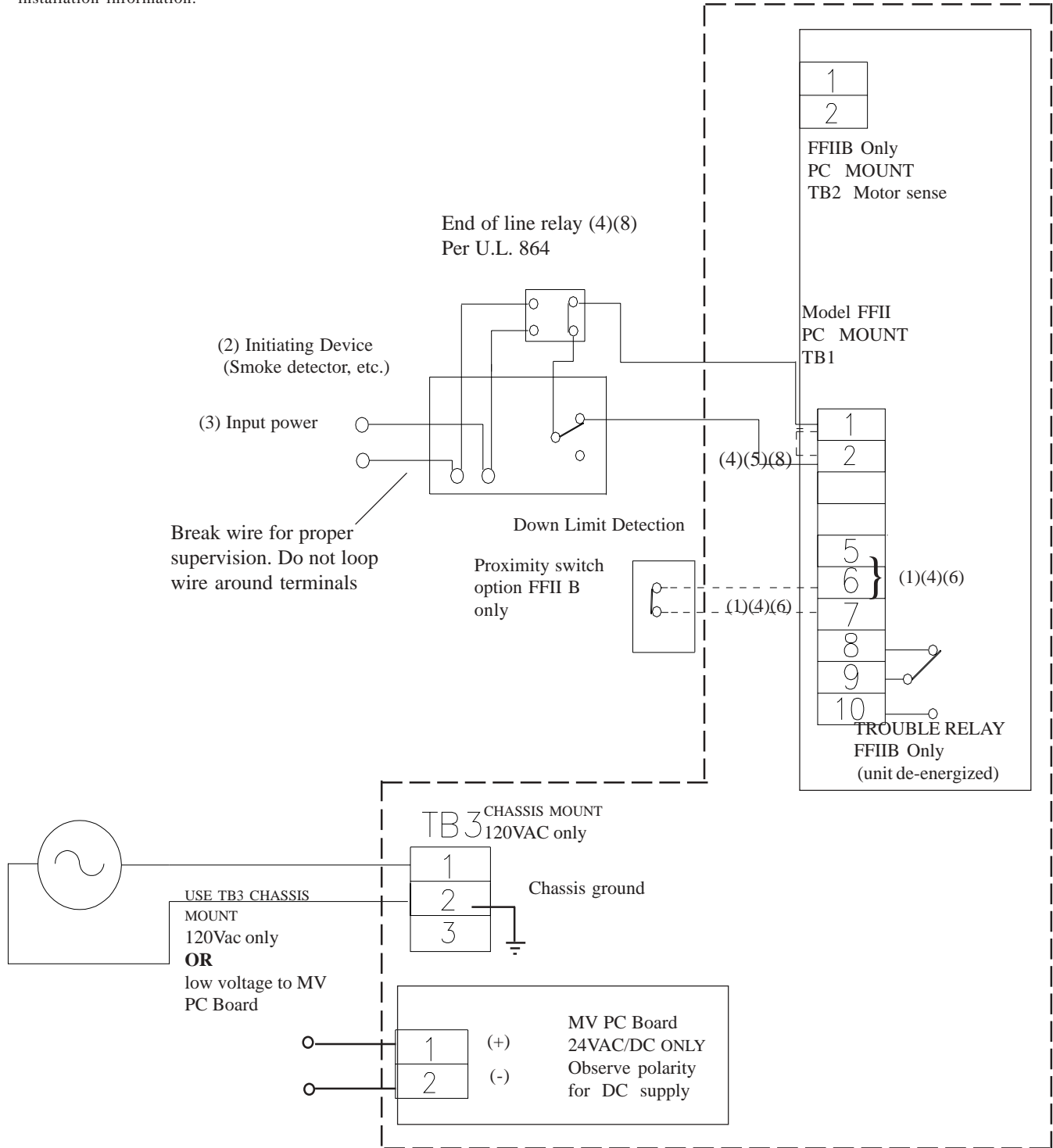

- (1) Dotted line indicates factory jumper which must be removed when connecting the N/C device.
- (2) See NFPA 80 and NFPA 92-1993 for proper placement.
- (3) Verify input voltage to model being used.
- (4) Maximum loop resistance 100 ohms. Verify contact rating of End of Line Relay.
- (5) Jumper must remain installed for two wire installation (figure 4A).
- (6) Jumper must remain installed if not using this option.
- (7) All fuses 2AG Fast Acting. See page 5, figures 5 & 5A for proper ratings
- (8) End of line relay as per U.L. 864** See smoke detector installation instructions for proper End of Line Relay p/n and contact ratings. Installation of all wiring and related connecting hardware must be performed in accordance with the latest NFPA, U.L., and N.E.C. standards and codes. In addition, all installations subject to Canadian standards shall be performed in accordance with the Canadian Electrical Code, Part I, with respect to wiring material type, wiring gauge related to power capacity requirements and circuit length and wiring methods.

FIGURE 4A - TWO WIRE/SINGLE DELAY

High voltage connections

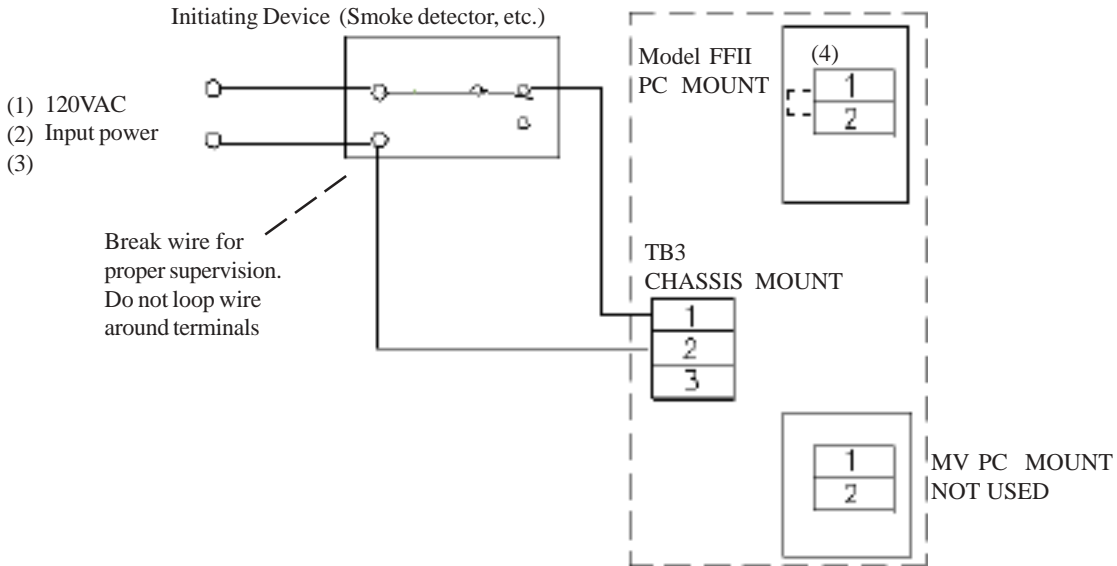

Low voltage connections

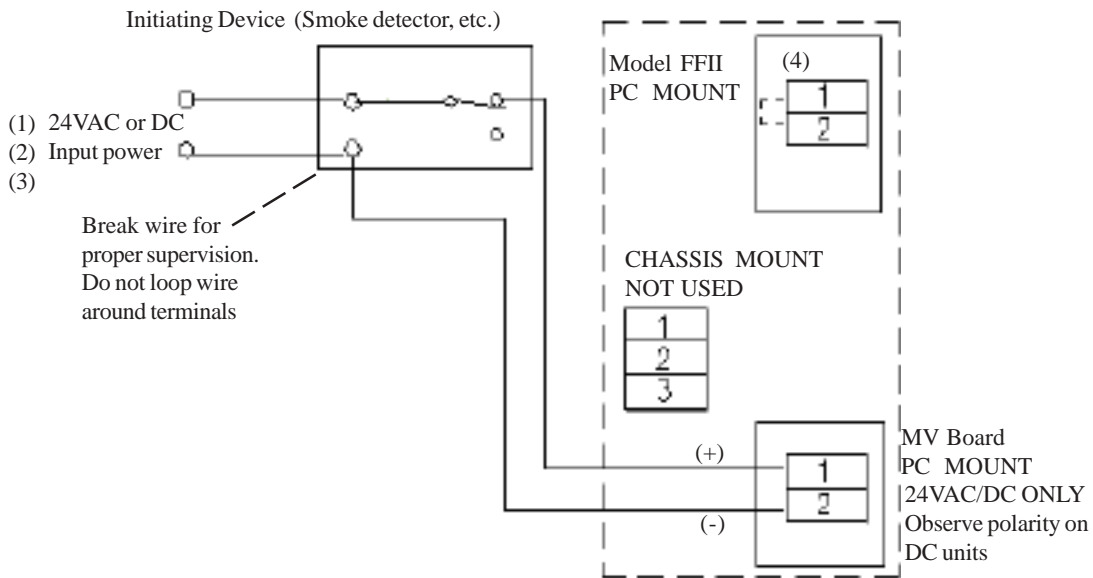

- (1) See NFPA 80 and NFPA 92-1993 for proper placement.
- (2) Verify input voltage to model being used.
- (3) See smoke detector installation instructions for contact ratings. Installation of all wiring and related connecting hardware must be performed in accordance with the latest NFPA, U.L., and N.E.C. standards and codes. In addition, all installations subject to Canadian standards shall be performed in accordance with the Canadian Electrical Code, Part I, with respect to wiring material type, wiring gauge related to power capacity requirements and circuit length and wiring methods.
- (4) Jumper must remain installed for two wire installation.
- (5) All fuses 2AG Fast Acting. See page 5, figures 5 & 5A for proper ratings

SECTION D. TEST PROCEDURES

TO BE PERFORMED BY FACTORY AUTHORIZED PERSONNEL ONLY! THE COOKSON COMPANY RECOMMENDS REGULAR TESTING OF ALL RELEASE DEVICE EQUIPMENT. TESTING SHALL BE WITNESSED FOR PROPER OPERATION.

Follow step A for electronic testing of Model Firefly II-MV. Step B refers to Model Firefly IIB-MV with Close Limit option. Step C power loss test may be performed on both models II and IIB. Testing does not affect normal operation of alarm system when connected to release device. Testing and normal operation can only be accomplished with power applied to unit. When power is applied to unit under test the Power LED (red) will be lit on the bottom of the release device.

CLEAR FIRE DOOR OPENING AND PROHIBIT ALL TRAFFIC THROUGH DOOR OPENING DURING TESTING OF SYSTEM!

Door must be in open position with power applied to unit to begin testing.

- A) 1. Depress and continue to hold test button on side of release device (figure 1). After factory adjusted 10 second alarm verification (10 sec. delay) device will release door. Release test button.
- 2. Reset and raise door, then reset release device by pushing reset lever in direction of arrow as indicated on device label. Fully insert end link through release device side opening and release reset lever to latch end link.
- B) 1. **Using chain hoist, lower door to fully closed position.**
- 2. Reset door, then release device by pushing reset lever in direction of arrow as indicated on device label. Fully insert end link through release device side opening and release reset lever to latch end link.
- 3. Verify that **Close Limit** LED (amber) is lit indicating "**the door is closed**". Depress and continue to hold test button on side of release device for 10 seconds. Active "Lower Limit" logic will prohibit the release device from energizing. Release test button.
- 4. Raise door to fully open position.

C. Power Loss Test.

- 1. Make sure door is in the fully open position. Turn off all power to release device (including motor control voltage when used on the model B). After approximately 10 seconds of continuous power loss, a mechanical release will be initiated.
- 2. Reset and raise door, then reset release device by pushing reset lever in direction of arrow as indicated on device label. Fully insert end link through release device side opening and release reset lever to latch end link.

After completing all tests, make sure door is in its normally open position and all power required for normal operation is restored to unit. This unit is designed to operate with power applied.

REMINDER:

Testing of the Firefly II-MV release device is independent of, and shall in no way be interpreted as an alternative method of, testing of the fire alarm system, motorized operator and/or any other system component employed on the fire door or counter fire door installation. TESTING SHALL BE PERFORMED AND WITNESSED FOR PROPER OPERATION.

MAINTENANCE REQUIREMENTS

The Firefly II-MV model release devices have no scheduled maintenance requirements. The unit has been designed and tested for use in indoor locations. The Cookson Company recommends weekly testing of the unit, but test intervals shall ultimately be subject to criteria established by the Final Authority Having Jurisdiction (AHJ).

To increase power loss release time turn VR1 CCW and to increase alarm release time turn VR2 CCW.

Serviceable fuses are provided for the following: See Figure 5 for fuse locations on release control board. Figure 5A illustrates fuses on Multi Voltage board.

Figure 5 fuses

- F1 3/4A @ 250v, 2AG Fast Acting, Logic Board Power Supply
- F2 3/4A @ 250v, 2AG Fast Acting, MODEL B ONLY
- F3 3/4A @ 250v, 2AG Fast Acting, Power Input

Replacement fuses may be ordered directly from the factory thru the technical support number provided below.

Should servicing of fuses be required, personnel authorized to perform such maintenance shall ensure that; a) all traffic is prohibited thru door opening, b) door is mechanically released and fully closed, c) all power is disconnected from unit.

After servicing equipment as required, unit shall be tested and witnessed for proper operation as described in **SECTION D- TEST PROCEDURES**, contained herein.

FIGURE 5 Fuses Firefly II circuit board

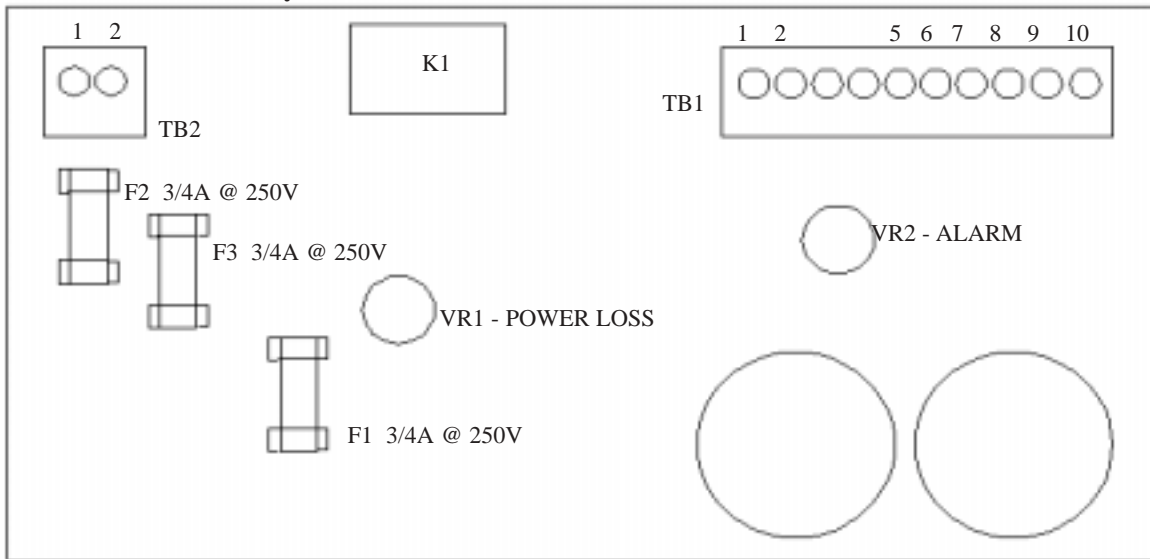
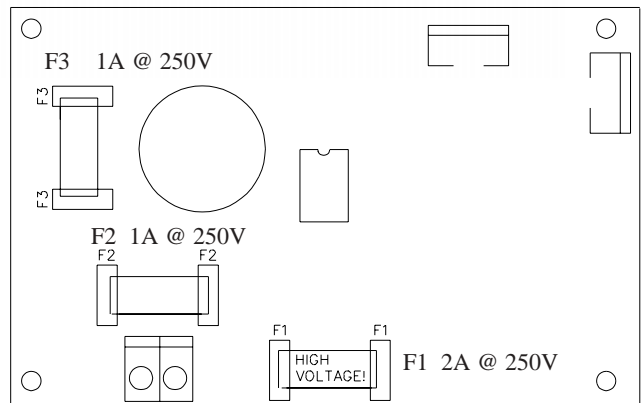

FIGURE 5A - Fuses MV circuit board

- F1 2A @ 250v, 2AG Fast Acting, high voltage input
- F2 1A @ 250v, 2AG Fast Acting, low voltage input
- F3 1A @ 250v, 2AG Fast Acting, low voltage output



Firefly II / IIB -MV TROUBLESHOOTING GUIDE

Verify that desired options are available on unit before troubleshooting. Refer to electrical connection information and the maintenance and service page of this manual for fuse locations. Troubleshooting shall be performed by factory authorized personnel only. Service and/or installation by unauthorized personnel shall void warranty. Review the following guide prior to requesting technical support. If technical support is required, unit serial number (found on front of manual and inside unit), as well as distributor who supplied unit must be supplied.

SYMPTOM

POSSIBLE TROUBLE

1. Red Power LED does not light.

- A) Primary power source turned off.
- B) Loose connection on TB3 or MV board
- C) Incorrect polarity on D.C. unit
- D) Incorrect power source applied. Verify voltage and check fuses F1 & F2 of both circuit boards.

2. Red LED is on, but unit does not release door after alarm or power loss delay.

- A) N/C Alarm loop is not connected properly to TB1. Remove wires from TB1, 1 & 2. Continuity test on wires should be zero ohms (short) back to initiating device. Place smoke detector in alarm and verify that dry contacts open on alarm.
- B) Unit is detecting down limit (FFII B only). If Down Limit feature is not being used, jumper must remain in TB1, 6 & 7.
- C) Load on release mechanism exceeds 40lbs. Remove sash chain and test with manual test button for proper release.
- D) Damaged unit. Call tech support.

3. Amber Disable LED does not light (Model B)

- A) Motor control voltage not connected to TB2
- B) Motor control is D.C.. Check polarity.
- C) Control voltage is above 30V. Check FFII B circuit board fuse F2.

4. Red LED is on, unit does not respond to manual test button, but works in alarm.

- A) Test button is not being depressed long enough. Depress button continuously for the 10 second delay. Unit must be powered up for a minimum of 15 seconds before testing.
- B) Unit is detecting down limit (FFII B only) Make sure Aux. down limit is connected properly. If N/O down limit is used, N/C loop (TB1-6&7) must have jumper installed.
- C) Possible defective switch. Call tech support.

5) Unit blows fuse when power is applied

- A) Incorrect power applied. Check unit label. Measure supply voltage.
- B) Unit has sustained damage from transient voltage. Call tech support.

UNIT SERIAL NUMBER _____ DISTRIBUTOR _____

TECHNICAL SUPPORT (602) 272-4244 9AM - 5PM MST MON-FRI

NOTES/TEST RECORDS

Copy this sheet and attach to manual for additional test data as required. Maintain test records in a secure location for future reference.

UNIT SERIAL NUMBER: _____

TEST DATE	PERFORMED BY	WITNESSED BY	COMMENTS
-----------	--------------	--------------	----------

