

**INSTALLATION INSTRUCTIONS
AND
OPERATION MANUAL**

**FS-200, FS-500 Series
Rolling Fire Door Operators**

UL325-2010 Compliant

Restricted Duty Operators

U.S. GEAR CORPORATION

IMPORTANT INSTALLATION INSTRUCTIONS

WARNING –To reduce the risk of death or serious injury to persons:

1. READ AND FOLLOW ALL INSTALLATION INSTRUCTIONS.

WARNING! – Components under **extreme spring tension** can cause death or serious injury.

2. Install only on a properly operating and balanced door. A door that is operating improperly could cause death or serious injury. Have trained door systems technicians make all necessary adjustments and repairs to the door before installing the operator.

Note: Fire door spring tension must be adjusted per the manufacturer's installation instructions to allow for automatic closing during a drop test, fusible link/alarm activation and/or power failure (Power failure condition only applies to operators capable of fail-safe closing).

3. Remove all pull ropes.
4. Unless the door operator includes an internal lock sensing system, or external electrical interlocks are installed, remove or make all door locks inoperative, or secure locks in the unlocked position to prevent operation with the locks engaged.
5. Install the door operator at least 8 feet or more above the floor if the operator has exposed moving parts. If it is installed less than 8 feet above the floor, any exposed moving parts must be covered or guarded.
6. Do not connect the door operator to the source of power until instructed to do so.
7. Locate the control station (open-close-stop push button, key station, or the like):
 - a) within sight of the door
 - b) at a minimum height of 5 feet above the floor so small children cannot reach it, and
 - c) away from all moving parts of the door.
8. Install the Entrapment Warning Placard next to the control station in a prominent location.
9. Make sure the available power supply to be connected to the operator is of the same voltage, frequency, phase and wattage as indicated on the nameplate of the operator.
10. Read and understand the wiring diagram of the operator and the control station and any other equipment to be connected to the operator.
11. Always disconnect power whenever installing or servicing the door operator or door.
12. All wiring must be permanent and comply with National Electrical Code (NEC) and local code requirements.

13. Any change in mounting position may result in a change of operator rotation and consequently in a change of control functions. Consult factory for any changes.
14. For products having a manual release, instruct the end user on the operation of the manual release.

SPECIFICATIONS

MOTOR	
Type:	Restricted cycle duty (30 cycles per hour)
Horsepower:	2 hp, 5 hp
Speed:	1700 RPM
Voltage:	230, 460, 575 – 3 phase 230 volt 3 phase motor is suitable for use with 208 volts
Current:	See motor nameplate
ELECTRICAL	
Transformer:	24VAC
Wiring Type:	Momentary pressure open, stop, constant pressure close (provided standard), with provision for momentary pressure close*
Limit Adjustment:	Linear driven, fully adjustable screw type cams.
MECHANICAL	
Drive Reduction:	72:1 (2 hp), 81:1 (5 hp)
Output Shaft Speed:	24 RPM (2 hp), 21 RPM (5 hp)
Door Speed:	6 - 8" per sec. average (typical)
Brake:	Solenoid actuated brake
ENTRAPMENT PROTECTION	
Sensing Edge*:	(Optional) Sensing device attached to the bottom edge of the door.
Non-Contact Device*:	(Optional) Photo eye device.
<p>* Per the requirements of UL Standard 325, the door operator is setup for constant pressure to close the door. As an alternative, the door may be provided with a monitored entrapment protection device that will reverse the door upon contact with or detection of an obstruction during closing. Adding an entrapment device would enable momentary close operation.</p>	

Notes:

1. Non-contact device (photo eye) can be used on doors up to 45 ft. wide (or maximum rated range of device if less than 45 ft.). Use a sensing edge to provide entrapment protection on doors over 35 ft. wide.
2. Sensing edge can be used on all doors.

TYPES AND SIZES OF DOORS

Consult factory for details.

INSTALLATION INSTRUCTIONS

INSTALLATION POSITIONS

LS

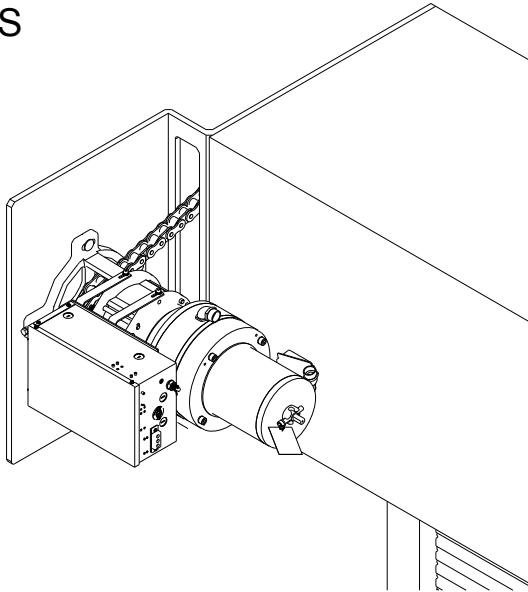

RS

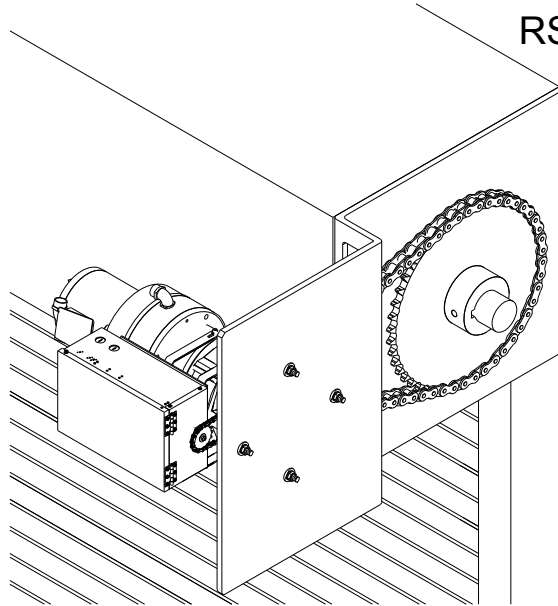

LA

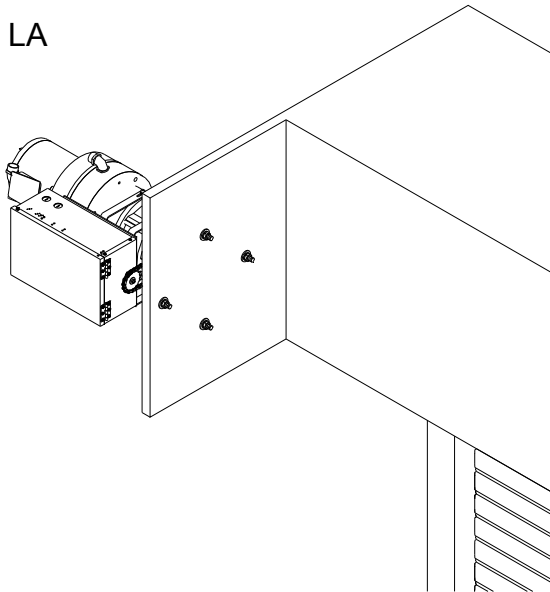

RA

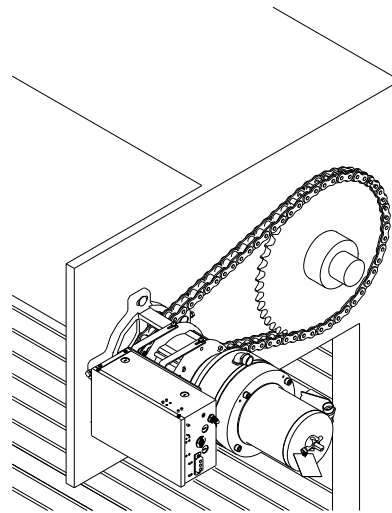

(Figure 1 for 2hp)

Consult factory for changes in installation positions.

NOTE: Any change in mounting position may result in a change of operator rotation and consequently in a change of control functions. Consult factory for any changes. (LH=LS and RA, RH=RS and LA)

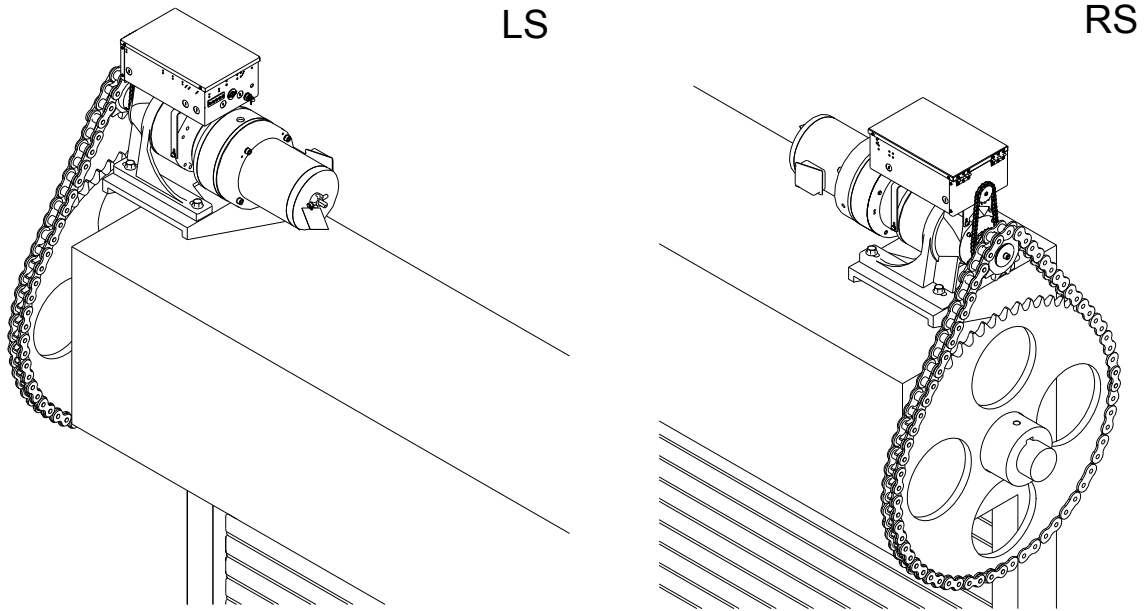

(Figure 2 for 5hp)

Consult factory for changes in installation positions.

NOTE: Any change in mounting position may result in a change of operator rotation and consequently in a change of control functions. Consult factory for any changes.

OPERATOR MOUNTING

1. Before the operator is installed, verify that the door is properly operating and balanced.
2. Make sure the layout of the mounting holes on the bracket is correct.

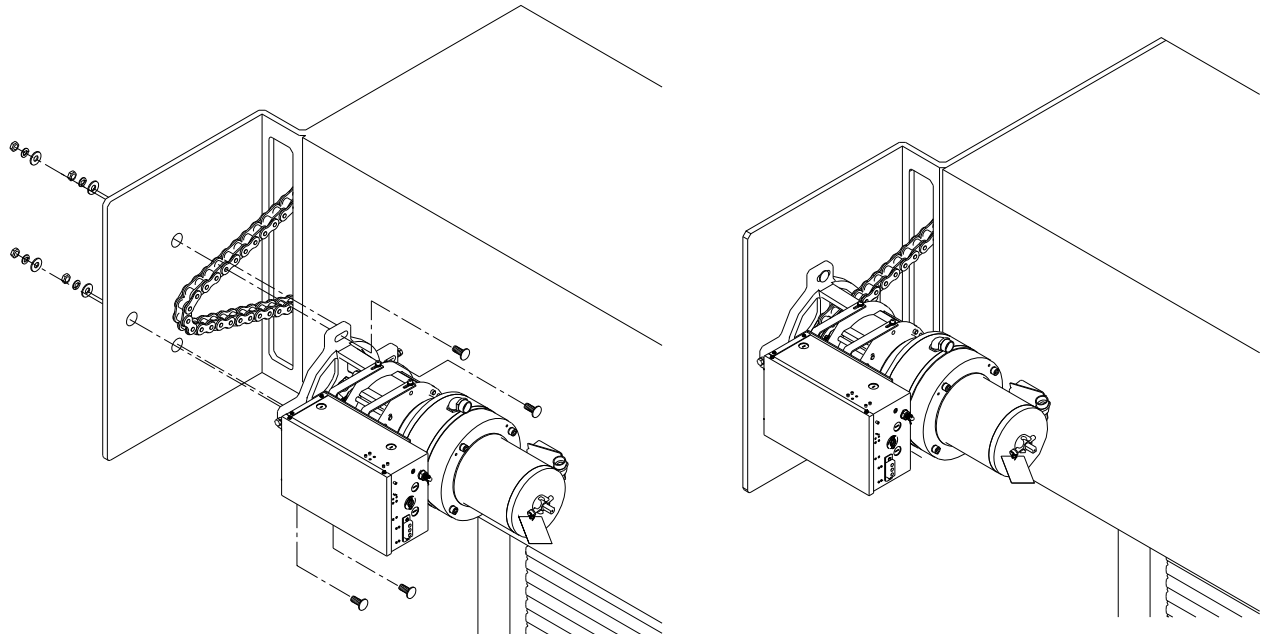

(Figure 3 for 2hp)

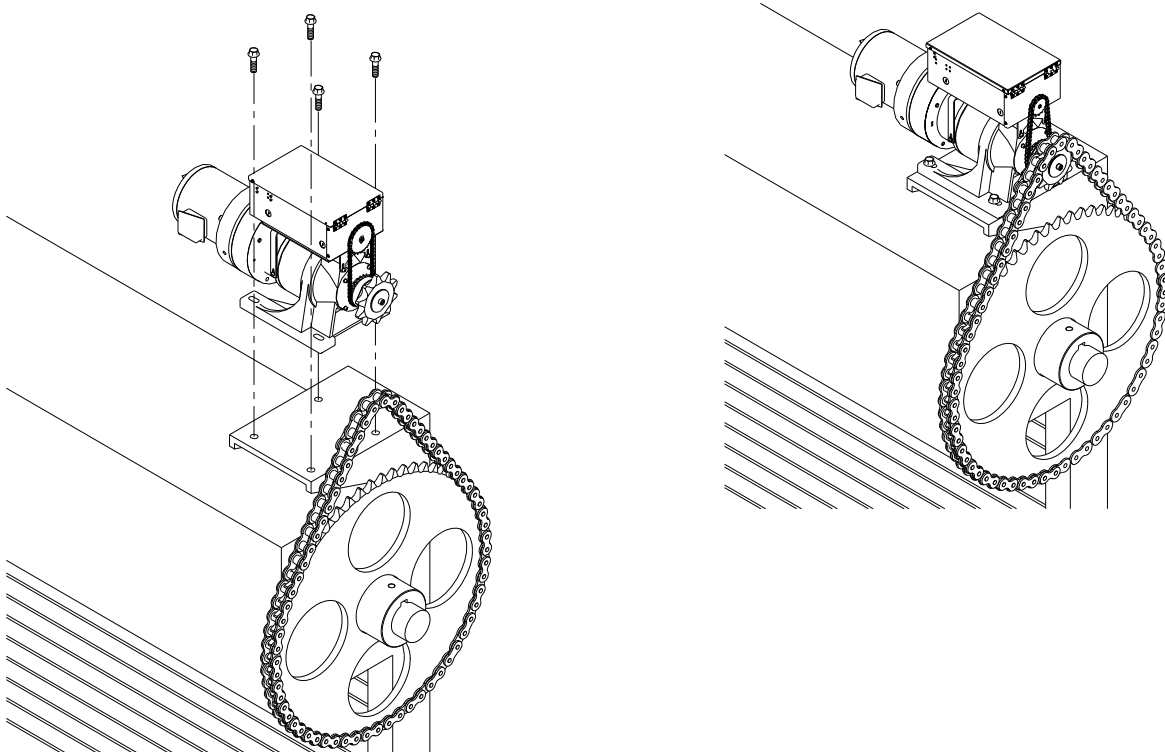

(Figure 4 for 5hp)

3. When the operator assembly is attached to the door bracket, be sure the door driven sprocket is properly aligned with the operator drive sprocket before securing the driven sprocket to the shaft.
4. The shelf or bracket must provide adequate support for the operator. Prevent play between the operator and the door shaft. The operator must be securely attached with the drive shaft parallel to the door shaft. It may be necessary to field brace the operator/bracket.

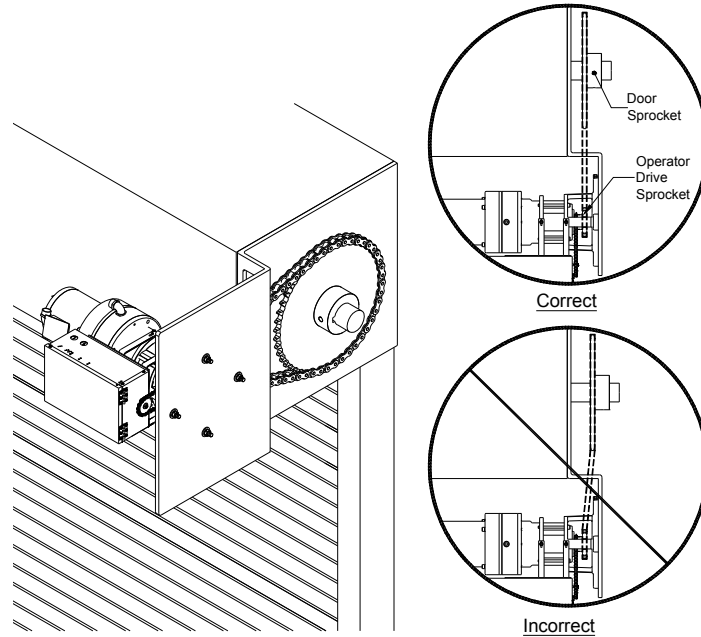

(Figure 5 for 2hp)

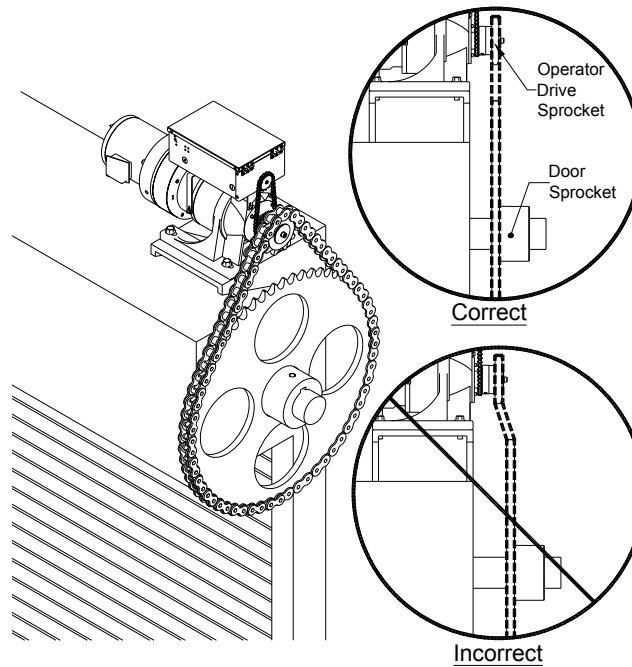

(Figure 6 for 5hp)

DRIVE CHAIN ADJUSTMENT

NOTE: Use correct type, size and proper length of roller chain.

1. Adjust the drive chain by tilting or move the operator so that there is about 1/4" of slack when the chain is depressed.

Note: The set screw included in the operator may be used for adjustment. (See figure - T3, T4 for 2hp).

2. Once the drive chain has been tightened and the base leg screws have been set, and then tighten the operator screws.

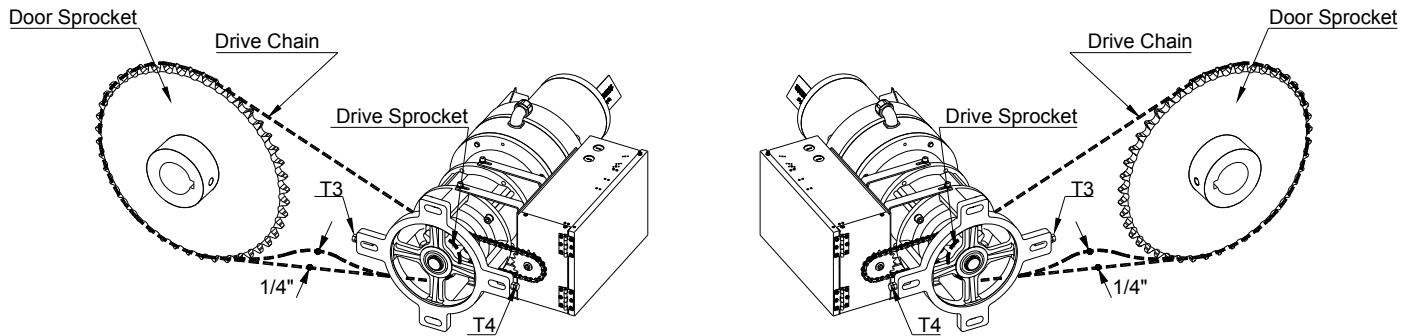

(Figure 7 for 2hp)

LS

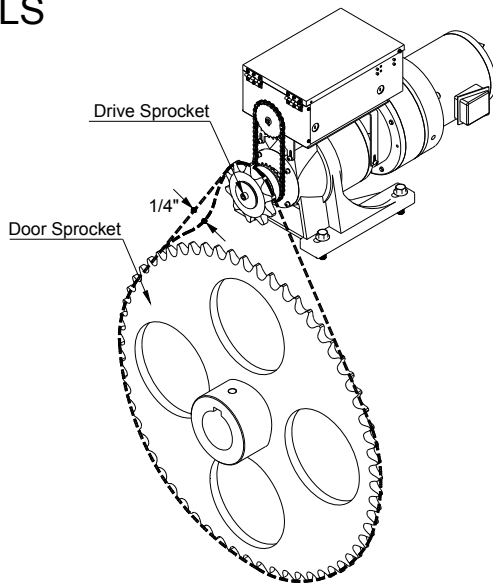

RS

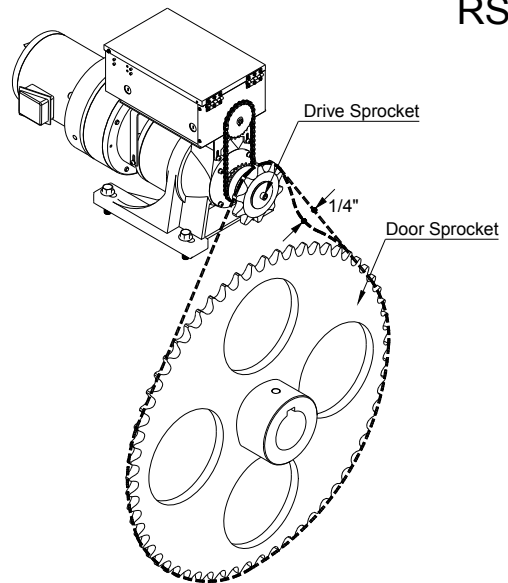

(Figure 8 for 5hp)

LIMIT SWITCH ADJUSTMENT

Make sure the limit cams are positioned between the limit switch actuators before proceeding with adjustments.

1. Open / remove the control panel cover.
2. Open or close door to determine the moving direction of the limit switch cams.
3. Open or close door to the desired position.



Disconnect power before adjusting limit switch cams.

WARNING

4. While pressing the spring-loaded lever (G), which holds the limit switch cams in place, adjust the limit switch cam (E or F) until the micro switch (C or D) clicking sound is heard.
5. If the limit switch cam cannot be rotated to its desired position, release the lever and move the door away from the desired position, then adjust the limit switch cam to its desired position. It may be necessary to repeat this step until the exact position has been reached.
6. Repeat step 3 and 4 for the opposite direction. Adjust close limit cams so that actuator is engaged as door fully seats at the floor.
7. Micro switch (A or B) can be adjusted to accommodate sensing edge cut-off position.

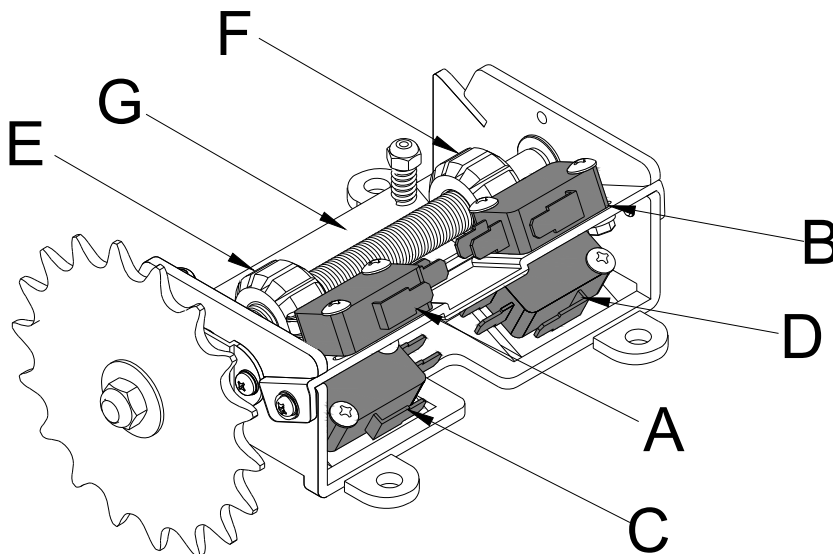

NOTE: "C" is usually the opening side and "D" is usually the closing side.

WIRING INSTRUCTIONS



Disconnect power at the fuse box before proceeding with any wiring.

WARNING

1. Do not install any wiring or attempt to run this operator without checking the wiring diagram located on the inside of the control box cover.
2. Do not turn on power until you have finished making all power and control wiring connections.
3. Do not run power and control wiring in the same conduit.
4. Any wire connected to the control panel must be protected by conduit or other means to ensure the safety and permanency of the wiring.
5. Use copper wire inside the control panel.
6. A separate fuse line of adequate capacity is needed for the operator.
7. The operator must be properly grounded. The ground screw, painted green, is located inside the control panel.



WARNING

Failure to properly ground the operator could result in electric shock and death or serious injury.



WARNING

Unless the operator includes an internal lock sensing system, or external electrical interlocks are installed, remove or make all door locks inoperative, or secure locks in the unlocked position. Failure to disable the locks could result in damage to the door or operator.

CONTROL WIRING



WARNING

If the door is not visible from the control station, or if any device other than the control station is used to activate the door, an entrapment protection device must be installed on the door. Failure to install an entrapment protection device may result in serious injury or death to person(s) trapped beneath the door.

1. Complete limit switch adjustments before making any sensing edge/non-contact device wiring connections to the operator.

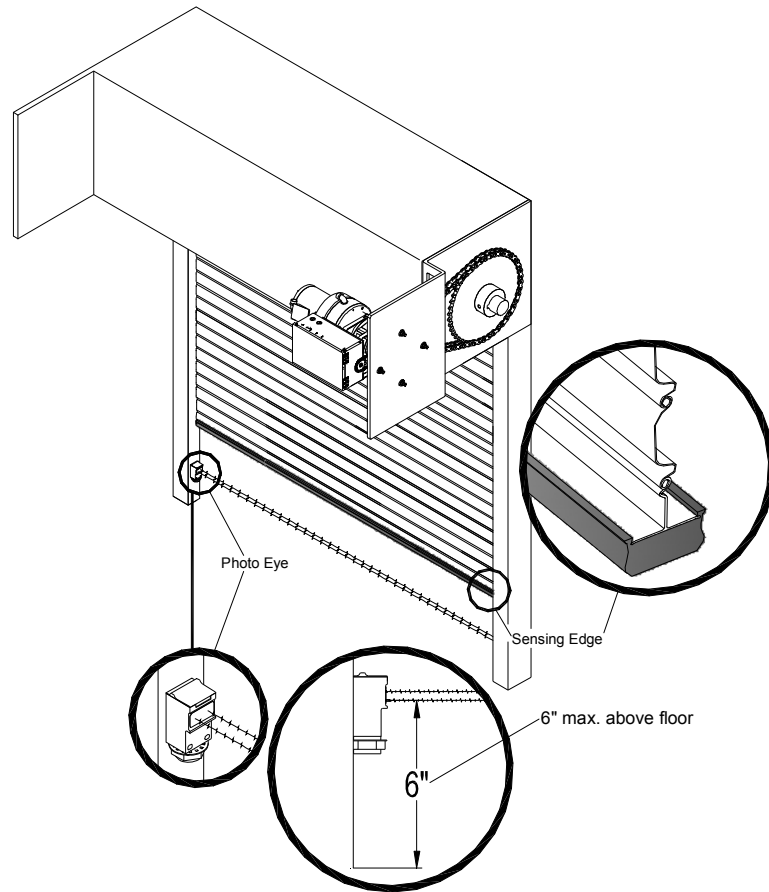

Entrapment Device Options:

Sensing Module	Device Manufacturer	Model
ELR 2-wire resistive sensing edge	Miller Edge Inc. * End of Line resistor type edge must have model number with Suffix T2.	ME110*, ME111*, ME120*, ME123*, ME112*, ME113*, ME116*, ME117*
		MT21*, MU21*, MT22*, MU22*, MC22*, MC271*
		CPT223*
IR Monitored photo eye	Martec Access Products. Inc.	1266
	FRABA Inc.	Optical Edge Sensors and Photo Eyes, Models OPTOEDGE, OPTOEYE; Part Nos. OSE-T, OSE-R, OSE-P, OPE.

Note: Please refer to sensing device manufacturer for specific installation and maintenance requirements.



Disconnect power at the fuse box before proceeding with any wiring.

WARNING

2. Locate the control station where the user can clearly see the operation of the door. Mount the enclosed placard adjacent or near the door.



WARNING

Controls shall be far enough from the door, or positioned such that the user is prevented from coming in contact with door while operating the controls.

3. Do not run control wiring in the same conduit as power wiring.
4. Any wire connected to the control panel must be protected by conduit or other means to ensure the safety and permanency of the wiring.



WARNING

Do not use radio controls with your operator unless some type of entrapment protection device has been installed. Failure to do so may result in death or serious injury to person(s) trapped beneath the door.



WARNING

Changing from left hand to right hand or vice versa could result in change of control wiring. Consult factory for details.

5. After installation, be sure that the operator, controls, and sensing edge or other entrapment protection devices have been tested and function properly.

FS 208/230V 3 PHASE (DRY CONTACT ALARM) LH (FOR FS-203E, 503E)

EB 1004EE L

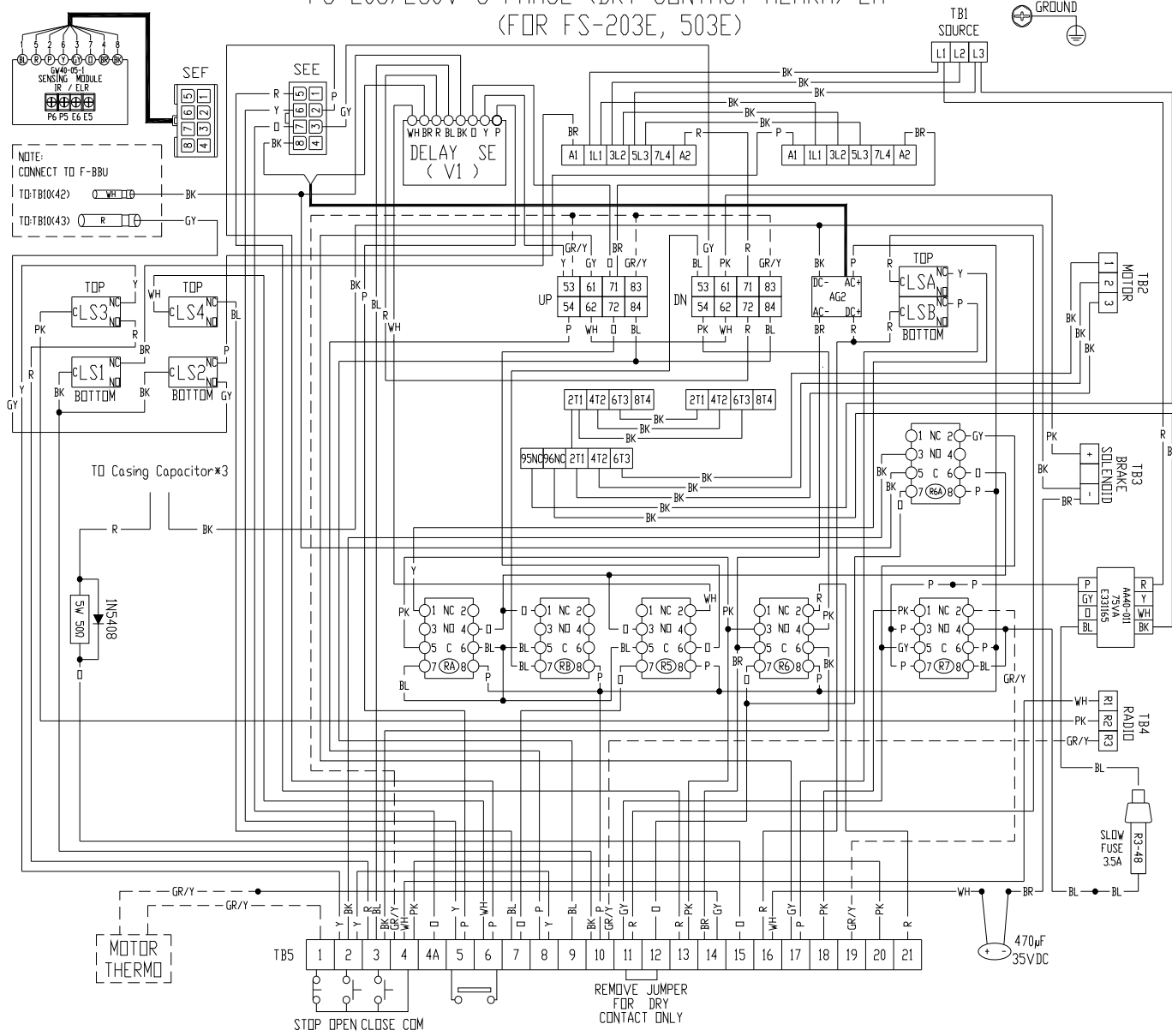

- NOTES:
- RA-WIRELESS EDGE RELAY (COIL 24VAC)
 - RB-GRAVITY DOWN RELAY (COIL 24VAC)
 - R5-SENSING-EDGE RELAY (COIL 24VAC)
 - R6-ALARM RELAY (COIL 24VAC)
 - R6A-ALARM RELAY (COIL 24VAC)
 - R7-EXTERNAL POWER SOURCE RELAY (COIL 24VAC)
 - SEF-SENSING MODULE CONNECTOR
 - LS1-OPEN MICROSWITCH
 - LS2-CLOSE MICROSWITCH
 - LS3-RADIO CONTROL MICROSWITCH
 - LS4-SENSING-EDGE MICROSWITCH
 - LSA-FUSIBLE LINK MICRO (TOP)
 - LSB-FUSIBLE LINK MICRO (BOTTOM)

SENSING MODULE TERMINAL:
E5&E6 CONNECT TO ELR SENSING DEVICE
P5&P6 CONNECT TO IR SENSING DEVICE



- TERMINAL NUMBER:
- 1 CONTROL STATION-STOP
 - 2 CONTROL STATION-OPEN
 - 3 CONTROL STATION-CLOSE
 - 4 CONTROL STATION-COMMON
- 4&4A JUMP FOR MOMENTARY CONTACT CLOSE WHEN ENTRAPMENT PROTECTION DEVICE IS INSTALLED
- 7&8 JUMP FOR S.E. TO REVERSE
- 9&10 DOOR MOVING WARNING SIGNAL 24VAC
- 15&16 JUMP FOR ALARM AND POWER FAILURE 10 SEC. DELAY
- 16&17 JUMP FOR FUSIBLE LINK 10 SEC. DELAY
- 18&19 EXTERNAL POWER INPUT 24VAC

ALARM FUNCTION	11&12	13&14	20&21
NO ALARM	JUMP	OPEN	OPEN
ALARM (G.V.DN)	DRY CONTACT	OPEN	OPEN
ALARM (P.W.DN)	DRY CONTACT	JUMP	JUMP

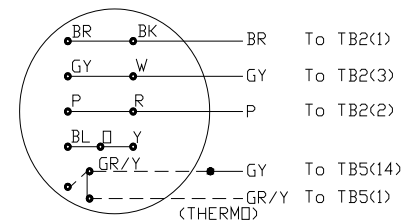

208V/230V 3 PHASE
MOTOR CONNECTION
2012.10.25

FS 208/230V 3 PHASE (DRY CONTACT ALARM) RH (FOR FS-203E, 503E)

EB 1004EE R

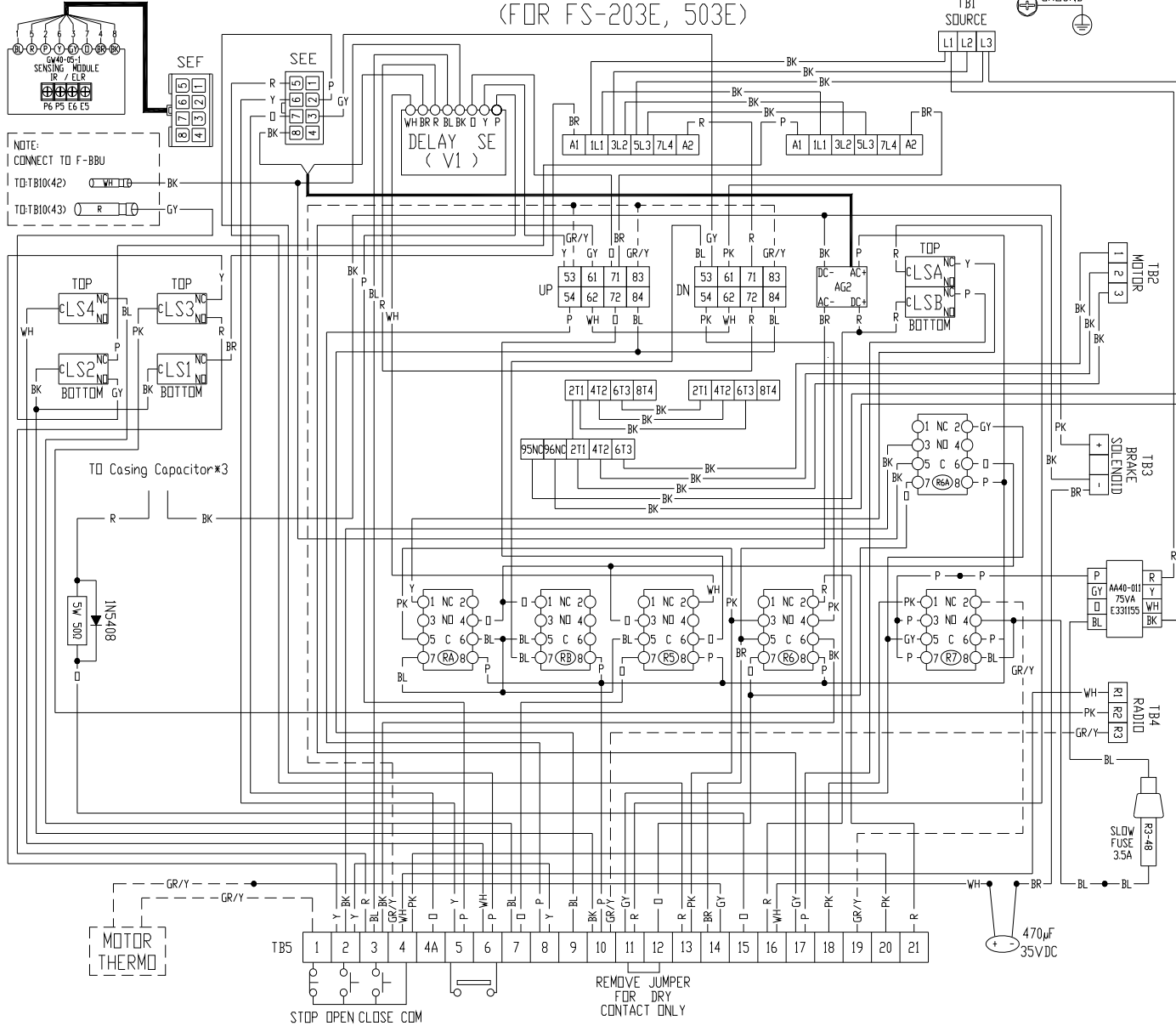

- NOTES:**
- RA-WIRELESS EDGE RELAY (COIL 24VAC)
 - RB-GRAVITY DOWN RELAY (COIL 24VAC)
 - R5-SENSING-EDGE RELAY (COIL 24VAC)
 - R6-ALARM RELAY (COIL 24VAC)
 - R6A-ALARM RELAY (COIL 24VAC)
 - R7-EXTERNAL POWER SOURCE RELAY (COIL 24VAC)
 - SEF-SENSING MODULE CONNECTOR
 - LS1-OPEN MICROSWITCH
 - LS2-CLOSE MICROSWITCH
 - LS3-RADIO CONTROL MICROSWITCH
 - LS4-SENSING-EDGE MICROSWITCH
 - LSA-FUSIBLE LINK MICRO (TOP)
 - LSB-FUSIBLE LINK MICRO (BOTTOM)

SENSING MODULE TERMINAL:
 E5&E6 CONNECT TO ELR SENSING DEVICE
 P5&P6 CONNECT TO IR SENSING DEVICE



- TERMINAL NUMBER:**
- 1 CONTROL STATION-STOP
 - 2 CONTROL STATION-OPEN
 - 3 CONTROL STATION-CLOSE
 - 4 CONTROL STATION-COMMON
 - 4&4A JUMP FOR MOMENTARY CONTACT CLOSE WHEN ENTRAPMENT PROTECTION DEVICE IS INSTALLED
 - 7&8 JUMP FOR S.E. TO REVERSE
 - 9&10 DDDR MOVING WARNING SIGNAL 24VAC
 - 15&16 JUMP FOR ALARM AND POWER FAILURE 10 SEC. DELAY
 - 16&17 JUMP FOR FUSIBLE LINK 10 SEC. DELAY
 - 18&19 EXTERNAL POWER INPUT 24VAC

ALARM FUNCTION	11&12	13&14	20&21
NO ALARM	JUMP	OPEN	OPEN
ALARM (GAV.DN)	DRY CONTACT	OPEN	OPEN
ALARM (PW.DN)	DRY CONTACT	JUMP	JUMP

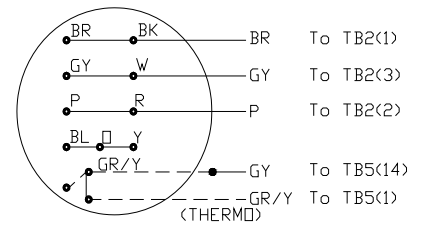

208V/230V 3 PHASE
 MOTOR CONNECTION

2012.10.25

FS 460V 3 PHASE (DRY CONTACT ALARM) LH (FOR FS-204E, 504E)

EB 2004EE L

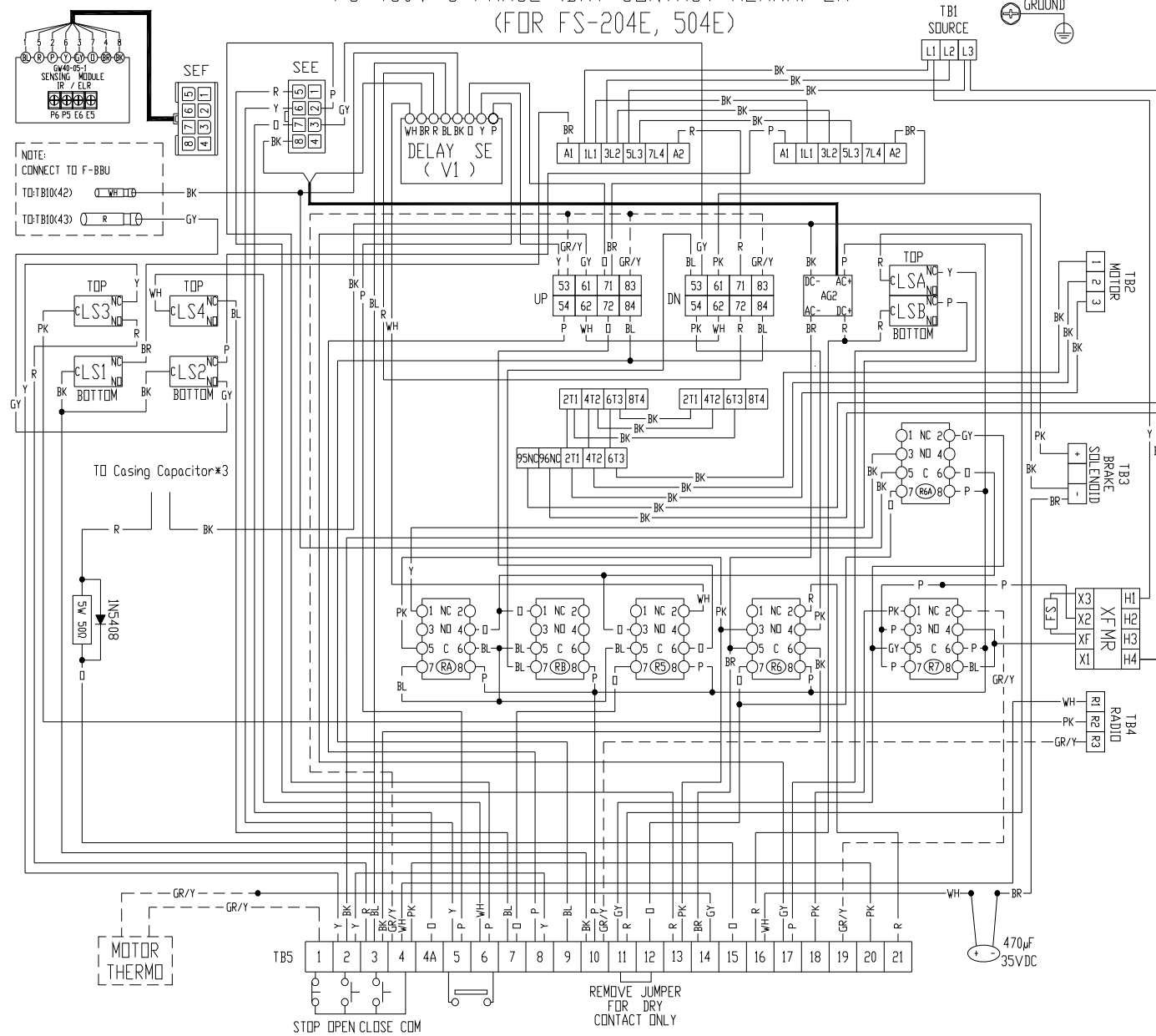

- NOTES:
- RA-WIRELESS EDGE RELAY (COIL 24VAC)
 - RB-GRAVITY DOWN RELAY (COIL 24VAC)
 - R5-SENSING-EDGE RELAY (COIL 24VAC)
 - R6-ALARM RELAY (COIL 24VAC)
 - R6A-ALARM RELAY (COIL 24VAC)
 - R7-EXTERNAL POWER SOURCE RELAY (COIL 24VAC)
 - SEF-SENSING MODULE CONNECTOR
 - LS1-OPEN MICROSWITCH
 - LS2-CLOSE MICROSWITCH
 - LS3-RADIO CONTROL MICROSWITCH
 - LS4-SENSING-EDGE MICROSWITCH
 - LSA-FUSIBLE LINK MICRO (TOP)
 - LSB-FUSIBLE LINK MICRO (BOTTOM)

SENSING MODULE TERMINAL:
 E5&E6 CONNECT TO ELR SENSING DEVICE
 P5&P6 CONNECT TO IR SENSING DEVICE



- TERMINAL NUMBER:
- 1 CONTROL STATION-STOP
 - 2 CONTROL STATION-OPEN
 - 3 CONTROL STATION-CLOSE
 - 4 CONTROL STATION-COMMON
 - 4&4A JUMP FOR MOMENTARY CONTACT CLOSE WHEN ENTRAPMENT PROTECTION DEVICE IS INSTALLED
 - 7&8 JUMP FOR S.E. TO REVERSE
 - 9&10 DOOR MOVING WARNING SIGNAL 24VAC
 - 15&16 JUMP FOR ALARM AND POWER FAILURE 10 SEC. DELAY
 - 16&17 JUMP FOR FUSIBLE LINK 10 SEC. DELAY
 - 18&19 EXTERNAL POWER INPUT 24VAC

ALARM FUNCTION	11&12	13&14	20&21
NO ALARM	JUMP	OPEN	OPEN
ALARM (GAV.DN)	DRY CONTACT	OPEN	OPEN
ALARM (PW.DN)	DRY CONTACT	JUMP	JUMP

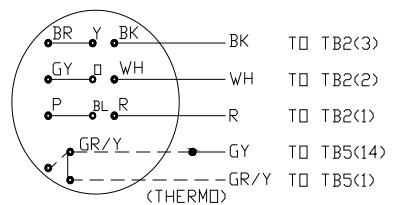

460V 3 PHASE
MOTOR CONNECTION

2012.10.25

FS 460V 3 PHASE (DRY CONTACT ALARM) RH (FOR FS-204E, 504E)

EB 2004EE R

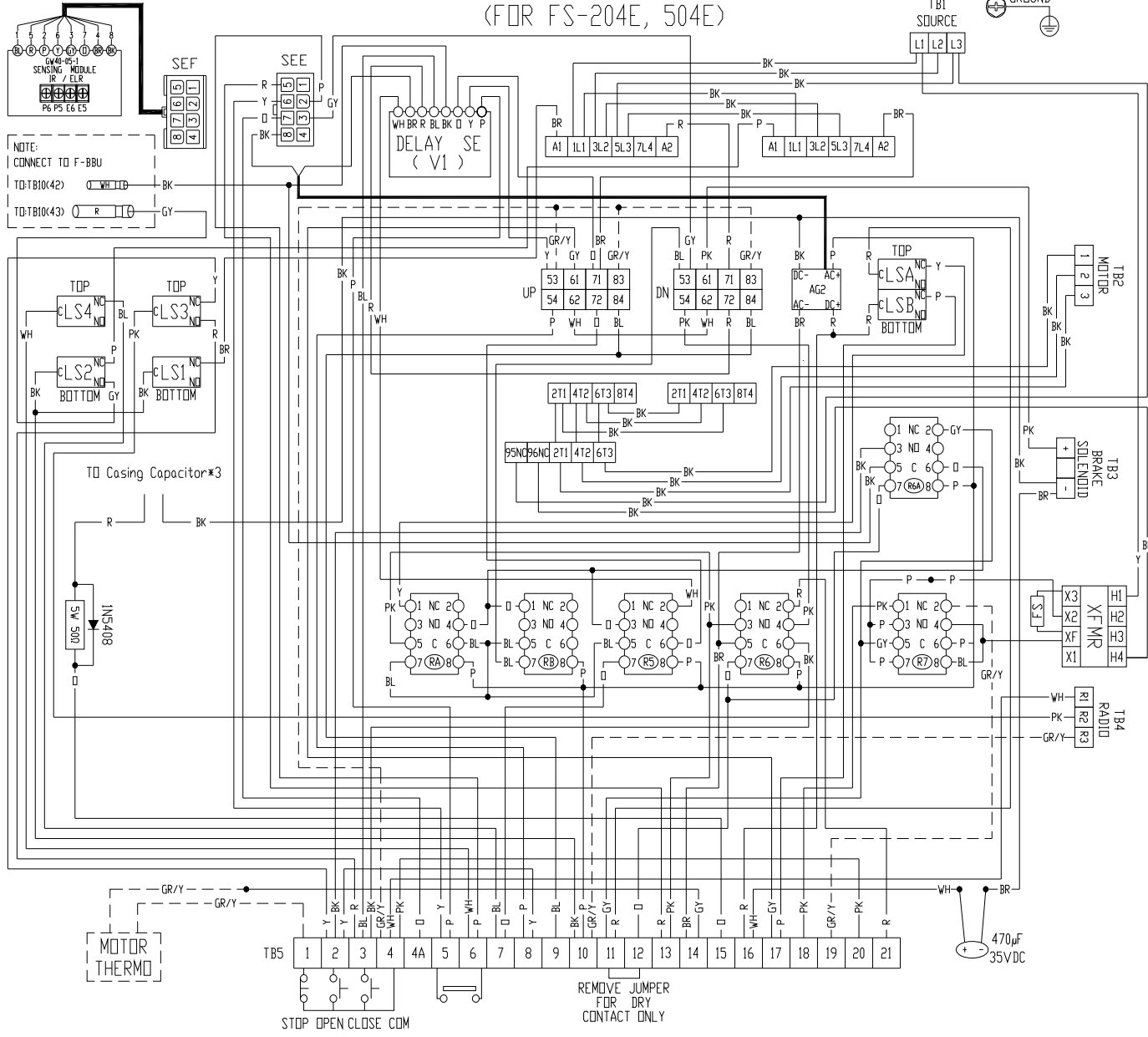

- NOTES:**
 RA-WIRELESS EDGE RELAY (COIL 24VAC)
 RB-GRAVITY DOWN RELAY (COIL 24VAC)
 RS-SENSING-EDGE RELAY (COIL 24VAC)
 R6-ALARM RELAY (COIL 24VAC)
 R6A-ALARM RELAY (COIL 24VAC)
 R7-EXTERNAL POWER SOURCE RELAY (COIL 24VAC)
 SEF-SENSING MODULE CONNECTOR
 LS1-OPEN MICROSWITCH
 LS2-CLOSE MICROSWITCH
 LS3-RADIO CONTROL MICROSWITCH
 LS4-SENSING-EDGE MICROSWITCH
 LSA-FUSIBLE LINK MICRO (TOP)
 LSB-FUSIBLE LINK MICRO (BOTTOM)

SENSING MODULE TERMINAL:
 E5&E6 CONNECT TO ELR SENSING DEVICE
 P5&P6 CONNECT TO IR SENSING DEVICE



- TERMINAL NUMBER:**
 1 CONTROL STATION-STOP
 2 CONTROL STATION-OPEN
 3 CONTROL STATION-CLOSE
 4 CONTROL STATION-COMMON
 4&4A JUMP FOR MOMENTARY CONTACT CLOSE WHEN ENTRAPMENT PROTECTION DEVICE IS INSTALLED
 7&8 JUMP FOR S.E. TO REVERSE
 9&10 DOOR MOVING WARNING SIGNAL 24VAC
 15&16 JUMP FOR ALARM AND POWER FAILURE 10 SEC. DELAY
 16&17 JUMP FOR FUSIBLE LINK 10 SEC. DELAY
 18&19 EXTERNAL POWER INPUT 24VAC

ALARM FUNCTION	11&12	13&14	20&21
NO ALARM	JUMP	OPEN	OPEN
ALARM (GAV.DN)	DRY CONTACT	OPEN	OPEN
ALARM (PW.DN)	DRY CONTACT	JUMP	JUMP

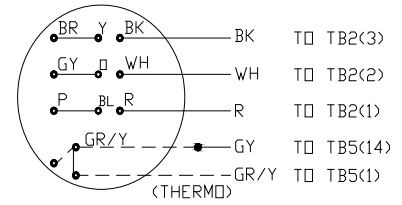

460V 3 PHASE
MOTOR CONNECTION

2012.10.25

FS 575V 3 PHASE 60Hz (DRY CONTACT ALARM) LH
(FOR FS-208E, 508E)

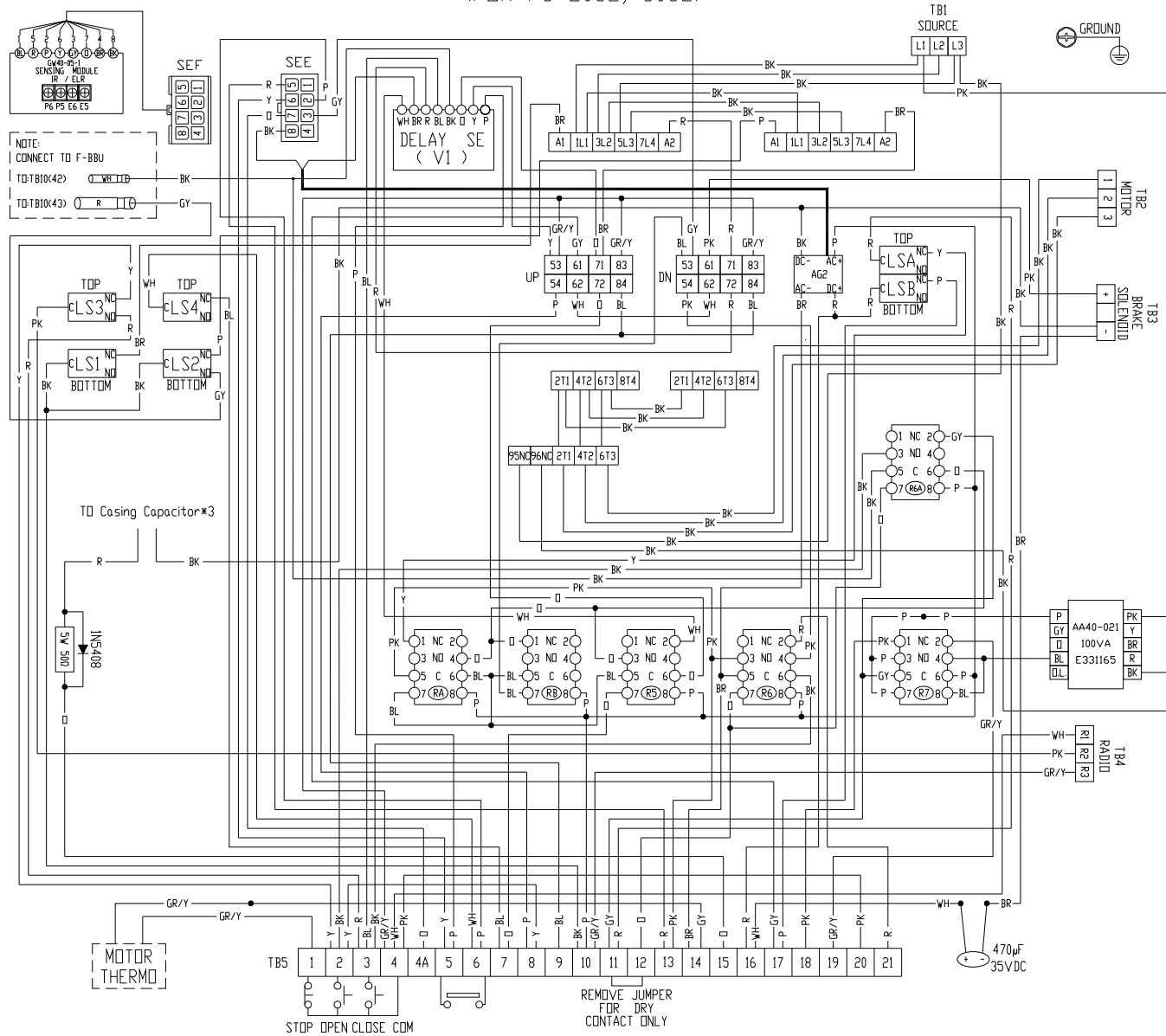

EB 4004EE L

- NOTES:
 RA-WIRELESS EDGE RELAY (COIL 24VAC)
 RB-GRAVITY DOWN RELAY (COIL 24VAC)
 R5-SENSING-EDGE RELAY (COIL 24VAC)
 R6-ALARM RELAY (COIL 24VAC)
 R6A-ALARM RELAY (COIL 24VAC)
 R7-EXTERNAL POWER SOURCE RELAY (COIL 24VAC)
 SEF-SENSING MODULE CONNECTOR
 LS1-OPEN MICROSWITCH
 LS2-CLOSE MICROSWITCH
 LS3-RADIO CONTROL MICROSWITCH
 LS4-SENSING-EDGE MICROSWITCH
 LSA-FUSIBLE LINK MICRO (TOP)
 LSB-FUSIBLE LINK MICRO (BOTTOM)

SENSING MODULE TERMINAL:
 E5&E6 CONNECT TO ELR SENSING DEVICE
 P5&P6 CONNECT TO IR SENSING DEVICE



- TERMINAL NUMBER:
 1 CONTROL STATION-STOP
 2 CONTROL STATION-OPEN
 3 CONTROL STATION-CLOSE
 4 CONTROL STATION-COMMON
 4&4A JUMP FOR MOMENTARY CONTACT CLOSE WHEN ENTRAPMENT PROTECTION DEVICE IS INSTALLED
 7&8 JUMP FOR S.E. TO REVERSE
 9&10 DOOR MOVING WARNING SIGNAL 24VAC
 15&16 JUMP FOR ALARM AND POWER FAILURE 10 SEC. DELAY
 16&17 JUMP FOR FUSIBLE LINK 10 SEC. DELAY
 18&19 EXTERNAL POWER INPUT 24VAC

ALARM FUNCTION	11&12	13&14	20&21
NO ALARM	JUMP	OPEN	OPEN
ALARM (GAV.DN)	DRY CONTACT	OPEN	OPEN
ALARM (PW.DN)	DRY CONTACT	JUMP	JUMP

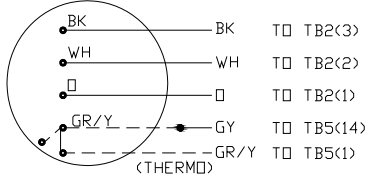

575V 3 PHASE
MOTOR CONNECTION

2012.10.25

FS 575V 3 PHASE 60Hz (DRY CONTACT ALARM) RH
(FOR FS-208E, 508E)

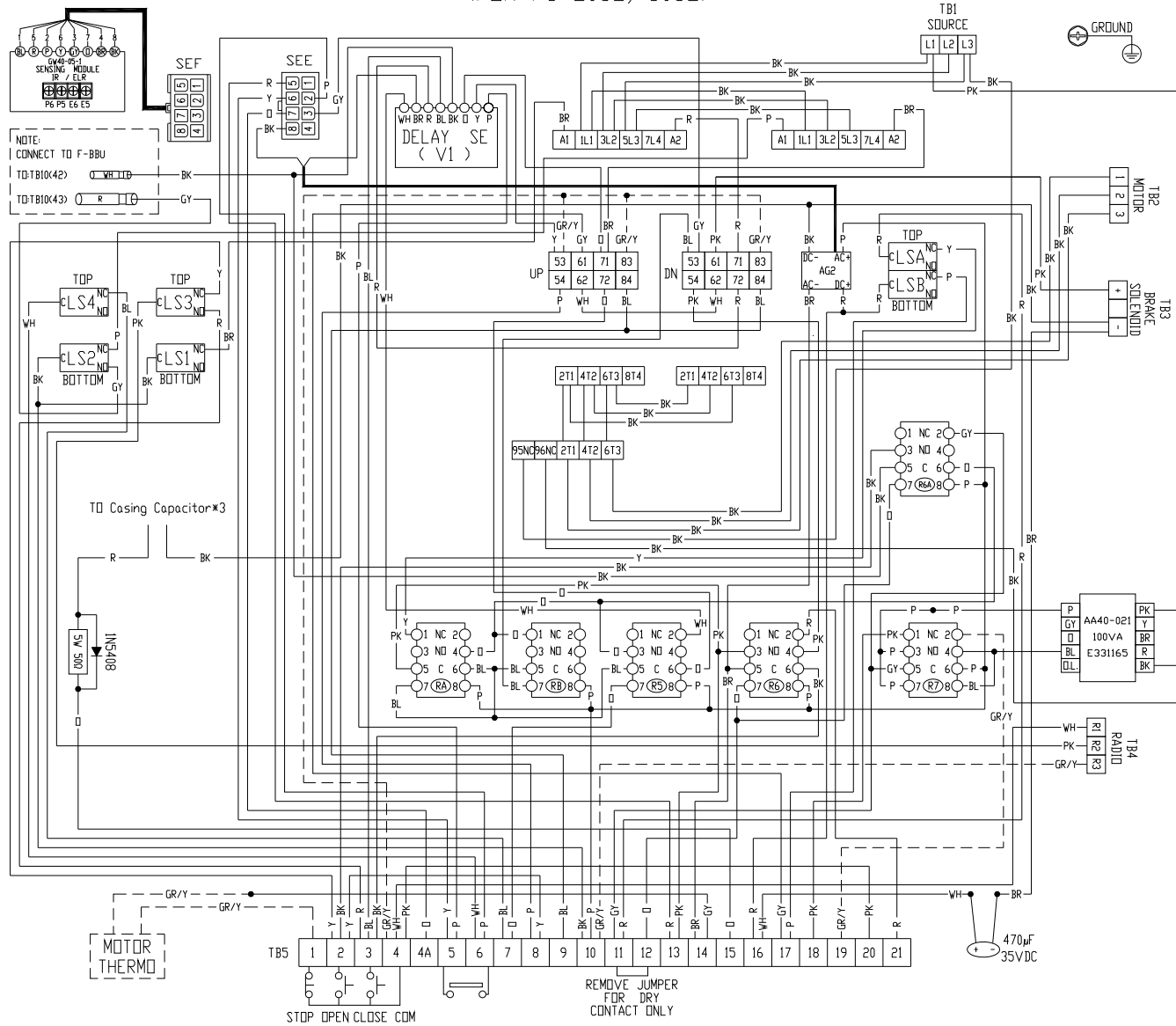

EB 4004EE R

- NOTES:
 RA-WIRELESS EDGE RELAY (COIL 24VAC)
 RB-GRAVITY DOWN RELAY (COIL 24VAC)
 R5-SENSING-EDGE RELAY (COIL 24VAC)
 R6-ALARM RELAY (COIL 24VAC)
 R6A-ALARM RELAY (COIL 24VAC)
 R7-EXTERNAL POWER SOURCE RELAY (COIL 24VAC)
 SEF-SENSING MODULE CONNECTOR
 LS1-OPEN MICROSWITCH
 LS2-CLOSE MICROSWITCH
 LS3-RADIO CONTROL MICROSWITCH
 LS4-SENSING-EDGE MICROSWITCH
 LSA-FUSIBLE LINK MICRO (TOP)
 LSB-FUSIBLE LINK MICRO (BOTTOM)

SENSING MODULE TERMINAL:
 E5&6 CONNECT TO ELR SENSING DEVICE
 P5&P6 CONNECT TO IR SENSING DEVICE

CONNECTOR
 SEE <=> ≡ ≡ ≡ ≡ => SEF

- TERMINAL NUMBER:
 1 CONTROL STATION-STOP
 2 CONTROL STATION-OPEN
 3 CONTROL STATION-CLOSE
 4 CONTROL STATION-COMMON
 4&4A JUMP FOR MOMENTARY CONTACT CLOSE WHEN ENTRAPMENT PROTECTION DEVICE IS INSTALLED
 7&8 JUMP FOR S.E. TO REVERSE
 9&10 DDDR MOVING WARNING SIGNAL 24VAC
 15&16 JUMP FOR ALARM AND POWER FAILURE 10 SEC. DELAY
 16&17 JUMP FOR FUSIBLE LINK 10 SEC. DELAY
 18&19 EXTERNAL POWER INPUT 24VAC

ALARM FUNCTION	11&12	13&14	20&21
NO ALARM	JUMP	OPEN	OPEN
ALARM (GAV.DN)	DRY CONTACT	OPEN	OPEN
ALARM (PW.DN)	DRY CONTACT	JUMP	JUMP

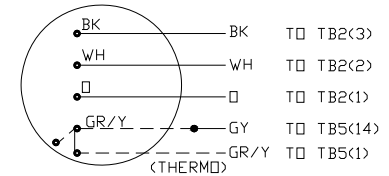

575V 3 PHASE
MOTOR CONNECTION

2012.10.25

Reference

Fail-Safe Series Terminal Connections

1	2	3	4	4A	5	6	7	8	9	10	11	12	13	14	15	16	17	18	19	20	21
Control Station					Sensing Edge Connection		S.E. Open to Stop		Door moving warning signal 24VAC		Alarm Connection		Alarm Function Please review Alarm Table		10 Sec. Delay for alarm signal			External power source input 24VAC		Alarm Function Please review Alarm Table	
Stop	Up Open	Down Close	Com				S.E. Jump to Reverse				N/C Dry Contact		Alarm Table			10 Sec delay for fusible link					
			*Jump for momentary contact close												If and only if alarm has delay, then fusible link has delay.						

Alarm Table

Alarm Function	Terminal		
	11&12	13&14	20&21
No Alarm	Jump	Open	Open
Alarm (Gravity Down)	Dry Contact	Open	Open
Alarm (Power Down)	Dry Contact	Jump	Jump

Notes:

1. When power closing in alarm and entrapment protection device comes in contact with an obstruction, door stops and then brake releases for gravity closing.
2. When in alarm and entrapment protection device is abnormal, door stops and then brake releases for gravity closing.

- ❖ *If momentary contact close is desired, an entrapment protection device must be installed, and then jump 4 and 4A.
- ❖ 10-second delay standard during power failure. Other delay adjustments can be made on the terminal strip.
- ❖ There is no 10-second delay under power closing during alarm.
- ❖ Control box comes with one-second delay on reverse.
- ❖ When the door is moving downward, activation of “Open” or “Stop” button will stop the door from moving.
- ❖ When the door is moving downward, the radio control transmitter can stop and reverse the door at anytime.
- ❖ For gravity closing during alarm, control has no power. The door will close under gravity.
- ❖ Per NFPA 80, if equipped with sensing edge, door will stop on the object during alarm.

Sensing Module connections

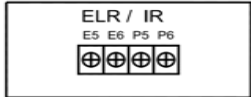
 <p style="font-size: small;">SENSING MODULE ELR / IR E5 E6 P5 P6</p>	E5 & E6 – Connect with ELR sensing edge
	P5 & P6 – Connect with Photo eyes or IR sensing edge

IMPORTANT SAFETY INSTRUCTIONS

WARNING –To reduce the risk of severe injury or death:

1. READ AND FOLLOW ALL INSTRUCTIONS.
2. Never let children operate or play with door controls. Keep the remote control (where provided) away from children.
3. Personnel should keep away from a door in motion and keep the moving door in sight until it is completely closed or opened. NO ONE SHOULD CROSS THE PATH OF A MOVING DOOR.
4. Test the door's safety features at least once a month. After adjusting either the force or the limit of travel, retest the door operator's safety features. Failure to adjust the operator properly may cause severe injury or death.
5. For products having a manual release, if possible, use the manual release only when the door is closed. Use caution when using this release when the door is open. Weak or broken springs may cause the door to fall rapidly, causing severe injury or death.
6. KEEP DOORS PROPERLY OPERATING AND BALANCED. See Door Manufacturer's Owner's Manual. An improperly operating or balanced door could cause severe injury or death. Have trained door systems technician make repairs to cables, spring assemblies, and other hardware.
7. **SAVE THESE INSTRUCTIONS.**

FUSIBLE LINK CONNECTIONS

- ❖ REMOVE COTTER PIN FROM RELEASE ASSEMBLY AFTER INSTALLATION IS COMPLETE.

Refer to the fire door installation instructions for connection of the release assembly or consult NFPA-80 and the authority having jurisdiction for fusible link location(s) and method.

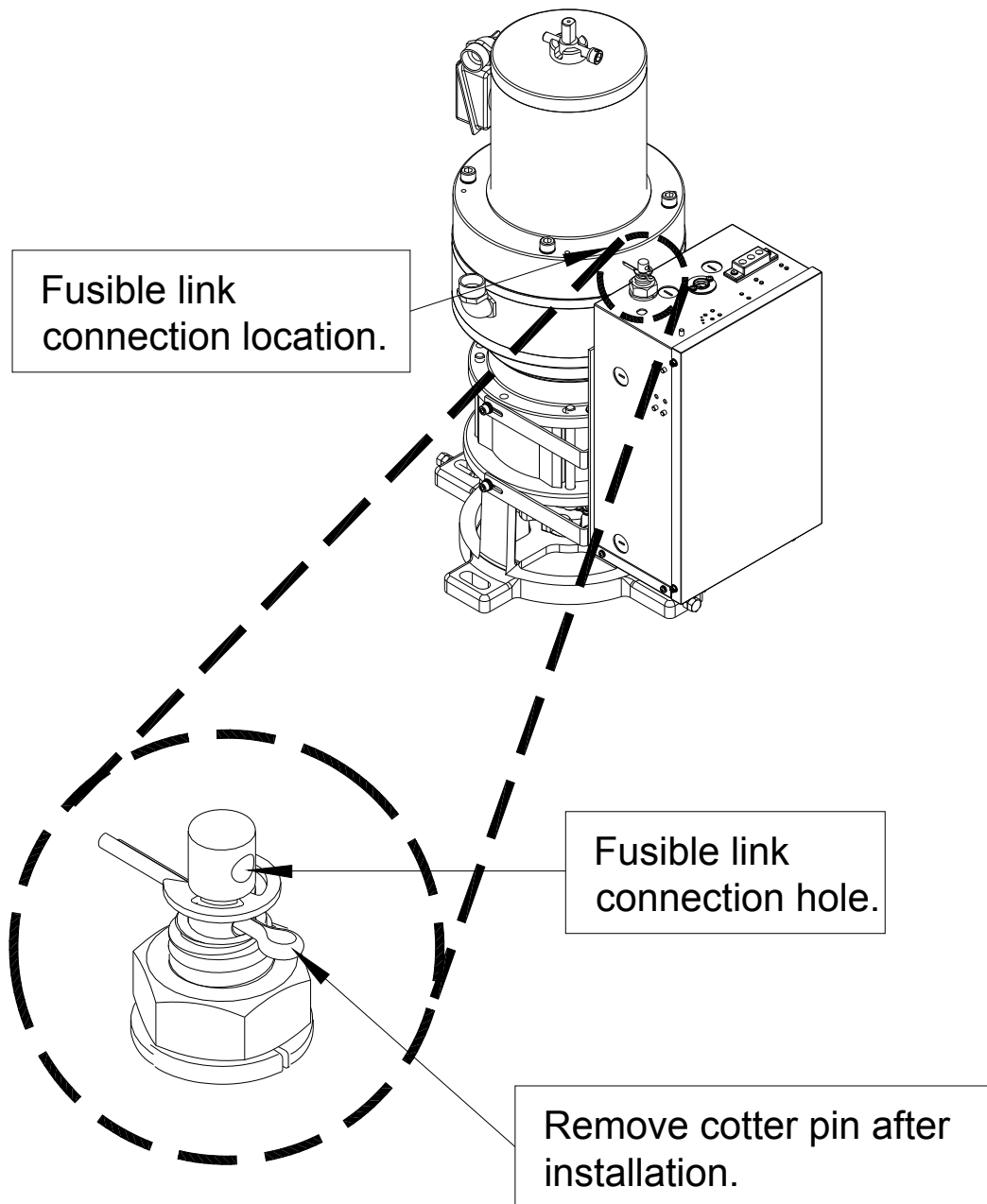

* Illustration only, not drawn to scale. See product for actual details.

OPERATING INSTRUCTIONS

1. If a 3-button control station is used to operate the door, push the “OPEN” button to open the door, push the “CLOSE” button to close the door, push the “STOP” button to stop movement of the door while opening or closing. Removing pressure from the “CLOSE” button will cause the door to stop.
2. If a key switch control station is used to operate the door, turn the key to the “OPEN” position to open the door, turn the key to the “CLOSE” position to close the door, push the “STOP” button to stop movement of the door while opening or closing. Removing pressure from the “CLOSE” key position will cause the door to stop.



WARNING

If a sensing edge is not installed on the bottom of the door, and removing pressure from the “CLOSE” button or key switch position does not cause the door to stop, this condition must be corrected immediately. Improper operation could result in serious injury or death to person(s) trapped beneath the door.

3. Door may also be operated by remote devices.

MAINTENANCE INSTRUCTIONS

The brake is a self-adjusting brake. It is maintenance free. The brake assembly requires no additional adjustments for its lifetime.

If an entrapment protection device is used, i.e. sensing edge or photoelectric sensors, please consult the manufacturer for maintenance instruction.



WARNING

Disconnect power supply to the operator before servicing.

Check the following items at the intervals listed:

CHECK LIST	DESCRIPTION	EVERY 3 MONTHS	EVERY 6 MONTHS	EVERY 12 MONTHS
Drive Chain	Check for excessive slack. Check & adjust as required Lubricate.	●		
Sprockets	Check set screw tightness	●		
Fasteners	Check & tighten as required		●	
Bearings & Shafts	Check for wear & lubricate	●		
Drop-test	Inspect door, drop-test for proper operation and full closure per NFPA-80			●

- ❖ Do not lubricate motor. Motor bearings are rated for continuous operation.
- ❖ Inspect and service whenever a malfunction either door or operator is observed or suspected.
- ❖ Before servicing, always disconnect power supply to the operator.
- ❖ Replace fuses only with those of the same type and rating.
- ❖ All replacement parts must be obtained from the door manufacturer per NFPA-80.



WARNING

Do not place hands or tools in or near the operator when the power is connected or when testing control or sensing devices. Always disconnect power before servicing or adjusting the operator.

APPENDIX 1

Control Connections Diagrams

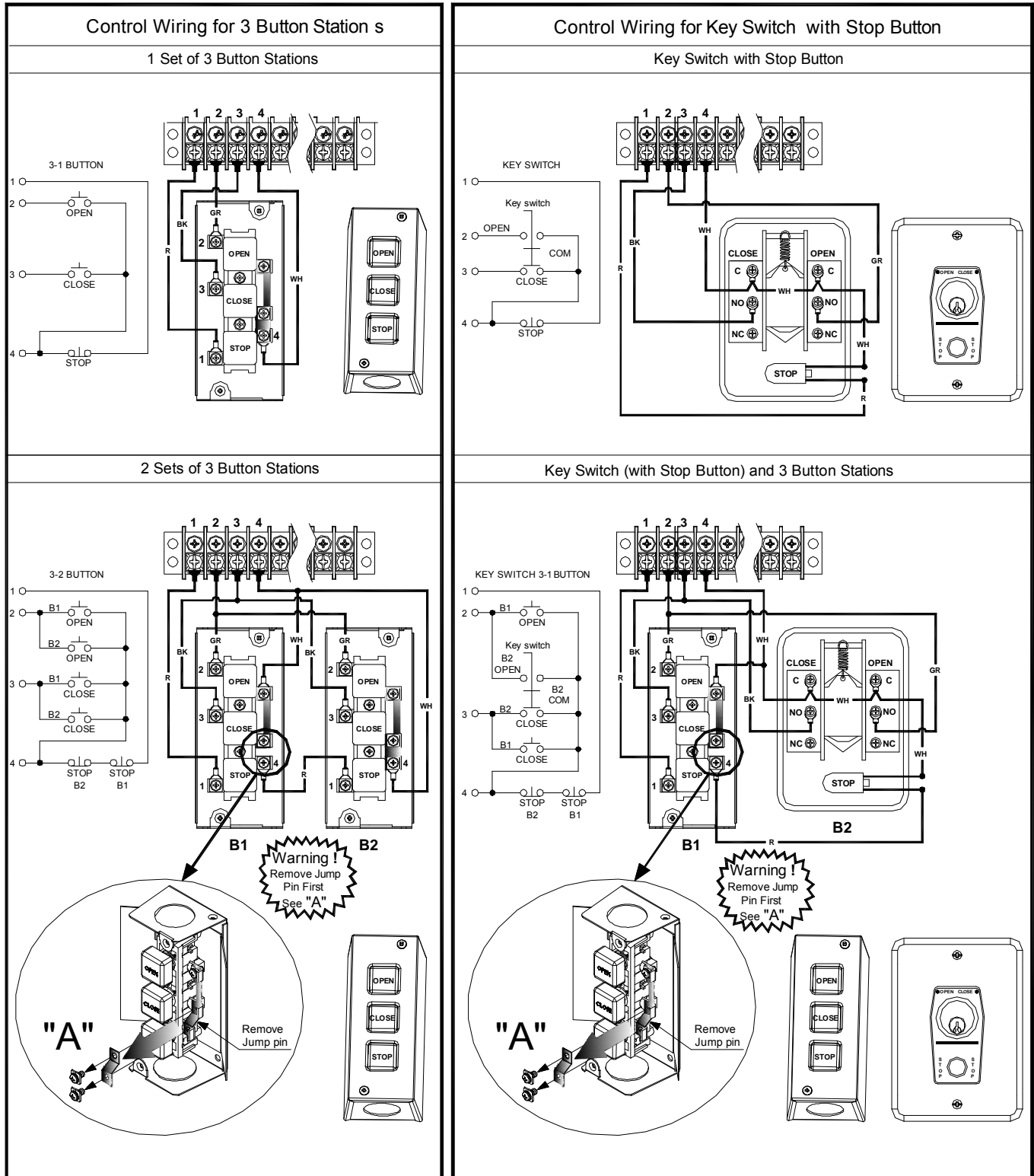

APPENDIX 2

Control Connections Diagrams

