

# ***Installation Instructions, 300 Series Door***

## Section 1 – Table of Contents





<b>Section 2 – Safety Check List.....</b>	<b>2</b>
<b>Section 3 – Freight Receiving.....</b>	<b>3</b>
<b>Section 4 – Pre-installation.....</b>	<b>4</b>
<b>Section 5 – Guides.....</b>	<b>5</b>
<b>Face Of Wall.....</b>	<b>5</b>
<b>Between Jambes.....</b>	<b>8</b>
<b>Section 6 – Barrel and Brackets.....</b>	<b>10</b>
<b>Preparation.....</b>	<b>10</b>
<b>Bracket Preparation.....</b>	<b>11</b>
<b>Hoisting and Installing Barrel Assembly.....</b>	<b>11</b>
<b>Section 7 – Motor Operator Installation.....</b>	<b>13</b>
<b>Section 8 – Curtain Installation.....</b>	<b>15</b>
<b>Section 9 – Sensor Mounting.....</b>	<b>17</b>
<b>Section 10 – Lintel Seal.....</b>	<b>18</b>
<b>Z Shape.....</b>	<b>18</b>
<b>L Shape.....</b>	<b>19</b>
<b>Section 11 – Hood, Fascia, and Covers.....</b>	<b>20</b>
<b>Hood Support Installation.....</b>	<b>20</b>
<b>Hood and Fascia Installation.....</b>	<b>22</b>
<b>Hood Splice Cover.....</b>	<b>23</b>
<b>Section 12 – Torque Specifications.....</b>	<b>24</b>
<b>Section 13 – Maintenance Schedule.....</b>	<b>25</b>
<b>Appendix A – Vinyl Guide Weather Seal.....</b>	<b>27</b>

## Section 2 – Safety Check List

Rolling doors are large, movable objects. They move with the help of electric motors or manual operators (chain, crank, push up, etc), and most have springs under high tension. These items and their components can cause injury. In order to avoid injury to yourself and others, please follow the instructions in this manual.

- **Review the potential hazards and preventative measures listed below:**

**Table 2.1 - Potential Hazards and Preventative Measures**

Potential Hazard	Preventative Measure	
	<p style="text-align: center;"><b>⚠ DANGER</b></p> <p style="text-align: center;"><b>Pinned or crushed by closing door.</b></p>	<ul style="list-style-type: none"> <li>• Keep yourself and others clear of opening while door is in motion.</li> <li>• Do not allow children to play near or operate door.</li> <li>• Do not operate if door becomes jammed or broken.</li> </ul>
	<p style="text-align: center;"><b>⚠ WARNING</b></p> <p style="text-align: center;"><b>Struck by adjusting wheel bar while applying spring turns.</b></p>	<ul style="list-style-type: none"> <li>• Be sure bar is adequate in strength and long enough to allow installer to apply the necessary torque.</li> <li>• Make sure bar is fully seated into the adjusting wheel slot before applying pressure.</li> <li>• Use two bars while applying turns to the adjusting wheel.</li> </ul>
	<p style="text-align: center;"><b>⚠ WARNING</b></p> <p style="text-align: center;"><b>Electrical shock.</b></p>	<ul style="list-style-type: none"> <li>• Make sure electrical operator is properly grounded.</li> <li>• Turn off source power completely prior to servicing the motor.</li> <li>• Make sure wires are clear of any moving or potentially moving parts.</li> <li>• Avoid pinching wires when installing the motor cover.</li> </ul>
	<p style="text-align: center;"><b>⚠ WARNING</b></p> <p style="text-align: center;"><b>Pinched by moving components.</b></p>	<ul style="list-style-type: none"> <li>• Make sure the motor is turned off and unplugged before working with moving parts such as roller chain and sprockets, drop-out mechanisms, adjusting wheels, etc.</li> <li>• Locate the possible pinch-points of the unit (Drive chain, coil area, bottom bar, etc.) Do not operate the door while someone is near these areas.</li> </ul>

- **Check the following during installation and before leaving the job site:**
  - a. If the unit has tension springs, be sure the proper amount of tension is applied to the torsion springs, in order to properly counterbalance the weight of the curtain.
  - b. Securely fasten the tension adjusting wheel in place with the appropriate hardware provided.
  - c. Check that the keys and/or cotter pins have been set in place and fit properly at all sprockets or gears.
  - d. Check that the setscrews in each sprocket or gear (one over the key and one offset from the key) have been tightened properly.
  - e. Check all fasteners holding the unit to the building structures.
  - f. Check all fasteners used to assemble the components of the unit together.
  - g. Instruct owner or representative in the proper method of operating the door.

### Section 3 – Freight Receiving

- **Upon delivery, check condition of components for damage.**
- **If damage occurred in transit, the installation should not proceed without authorization.**

#### **NOTICE**

If the installation proceeds, neither the carrier nor the manufacturer will assume responsibility for replacing the damaged material.

- **If the installation is stopped due to damage, do the following:**
  1. Take pictures of the damage.
  2. Do not move material from point of delivery to other premises once the damaged components are discovered.
  3. Do not unpack, if the damage is visible prior to removing packaging, until an inspection is made.
  4. If the damage is found while removing contents from packaging, the packaging material must be saved until inspection is made.
  5. Container and packaging should be retained by consignee until inspection is made.
  6. Have components inspected by carrier's representative within 15 days from date of delivery.
  7. Consignee must obtain a copy of the Inspection Report.
- **Returning damaged components:**
  1. Obtain permission from carrier to return.
  2. Route the return shipment via the identical carrier(s) involved in the original shipment.
  3. Notify the manufacturer when shipment is returned to manufacture plant.
- **Verify that all components have arrived. Look for the following:**
  1. Job construction drawings featuring different views (elevation, section, plan, etc.)
  2. (2) Guide assemblies; check for guide weathering if included in order
  3. Barrel assembly
  4. Curtain assembly with bottom bar attached
  5. (2) Bracket assemblies
  6. Operator; if not attached to bracket
  7. Operator cover; may not be included in order
  8. Adjusting wheel; if the barrel assembly contains springs
  9. Inertia brake; typically on units with springless barrel assemblies
  10. Hood and hood supports; may not be included in order
  11. Hardware
  12. Misc. items (Reelite, lintel seal, hood baffle, etc.)
  13. Verify material/finish/color of components matches what is listed on the job construction drawings and/or what was ordered.
- **If the delivery is incomplete:**
  1. Make note on delivery receipt.
  2. Note should be verified by driver's signature.
  3. Notify carrier and manufacturer.

## Section 4 - Pre-installation

- **Read entire instruction manual thoroughly. The manufacturer will not be held responsible for any charges incurred due to improperly installed components.**
  - a. Only trained door systems technicians should perform installation, maintenance, etc.
  - b. Each unit comes with an individual item number. If the job contains multiple units, be sure to locate all the components for each item and separate each.

### **⚠ WARNING**

**Do not** interchange parts from one door to another.

- c. Find the job construction drawings for the unit being installed and check the dimensions of the opening against those on the drawings. See **Figure 4.1** below.
- d. If the opening dimensions differ from those on the drawings, **do not proceed**, check with distributor/manufacturer to be sure the correct door is being installed.
- e. Check the jambs of the opening for plumb. Check the head/lintel and floor for level. If the unit is to be free standing, for example mounted to tubes, check the floor and ceiling for level and for adequate mounting areas at the top and bottom.

**Note:** *The floor may not be level if a pitched bottom bar is specified.*

- **Work Area:**
  - a. The key to a smooth installation is a clean and well-prepared work environment. Once the components have been inspected and the job construction drawings have been reviewed; lay out the components in the order of installation.
  - b. The opening for the door should be cleaned and inspected for rough surfaces and construction debris.
  - c. Lastly the mounting hardware supplied with the door should correspond with the surface and construction features of the opening.
  - d. The basic assembly sequence is as follows: guides, barrel w/ rings or tapped holes, brackets, motor operator (if applicable), curtain, bellmouth, weather stripping, hood, and operator/adjustor/idler covers.

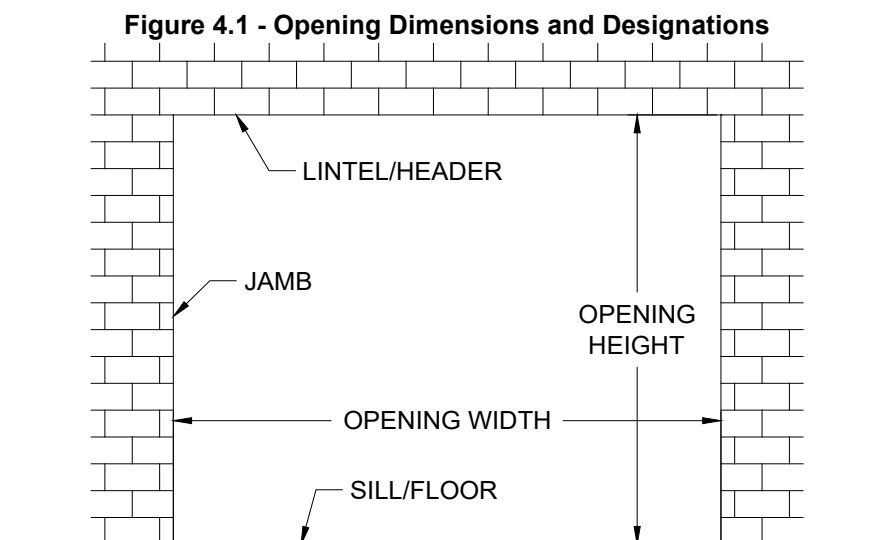

## Section 5 – Guides

### ▪ Face of Wall Units (Figures 5.1 - 5.4):

**Note:** Determine which guide assemblies are utilized on the unit from the job construction drawings and compare to the diagrams below.<sup>1</sup>

**Figure 5.1 – Face of Wall “Z” Guide**

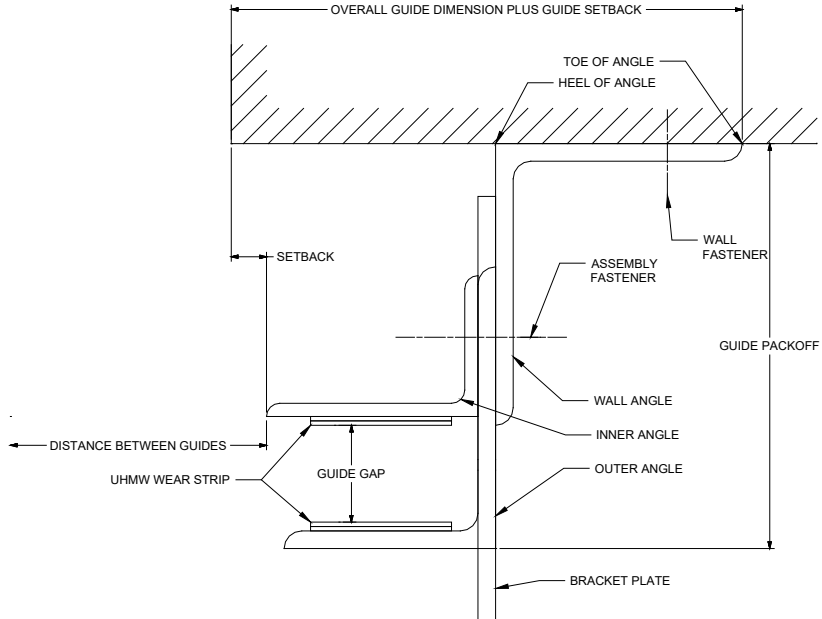

**Figure 5.2 – Face of Wall “Z” Guide With Windlock Flat**

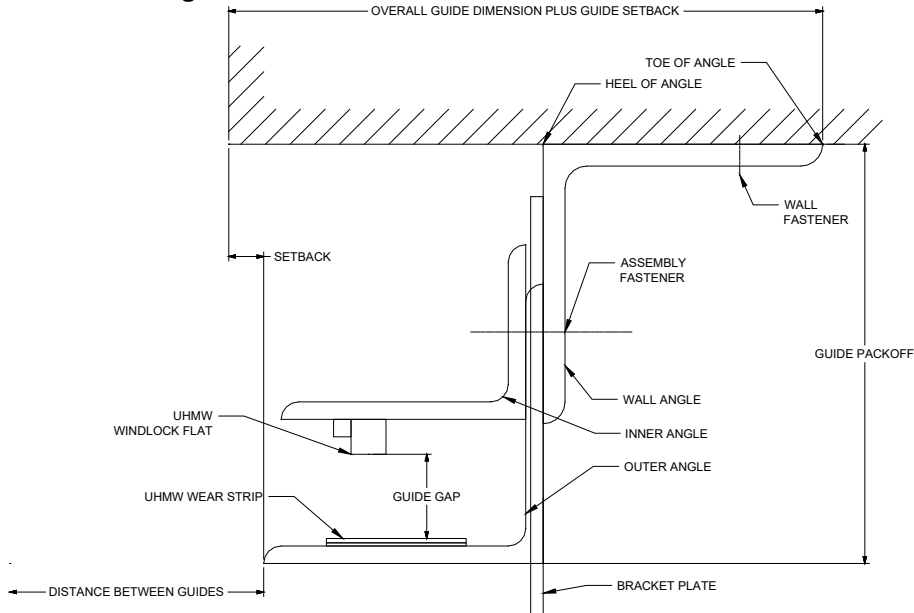

<sup>1</sup> The guide assembly may differ from the right to left hand side of the unit. In these cases, follow the directions for each particular guide assembly, as well as the job construction drawings provided with the unit.

## Section 5 – Guides

### Figure 5.3 – Face of Wall “E” Guide

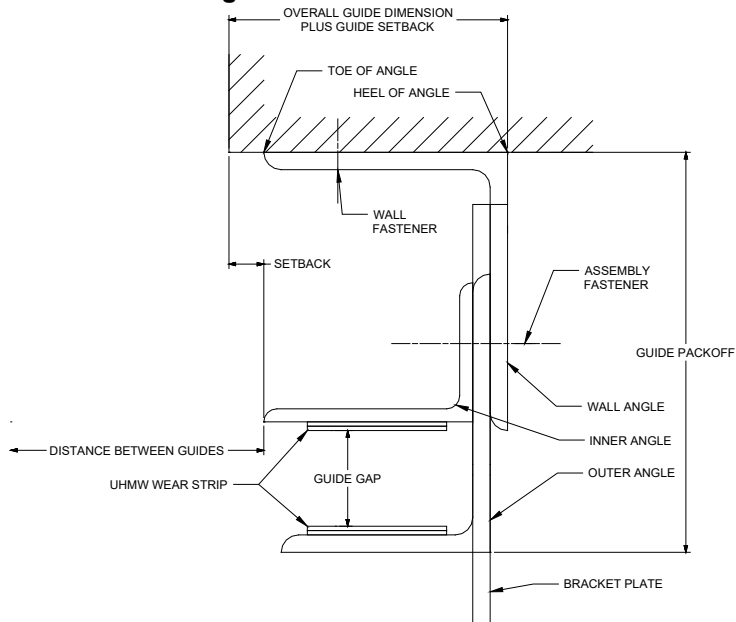

### Figure 5.4 – Face of Wall “E” Guide With Windlock Flat

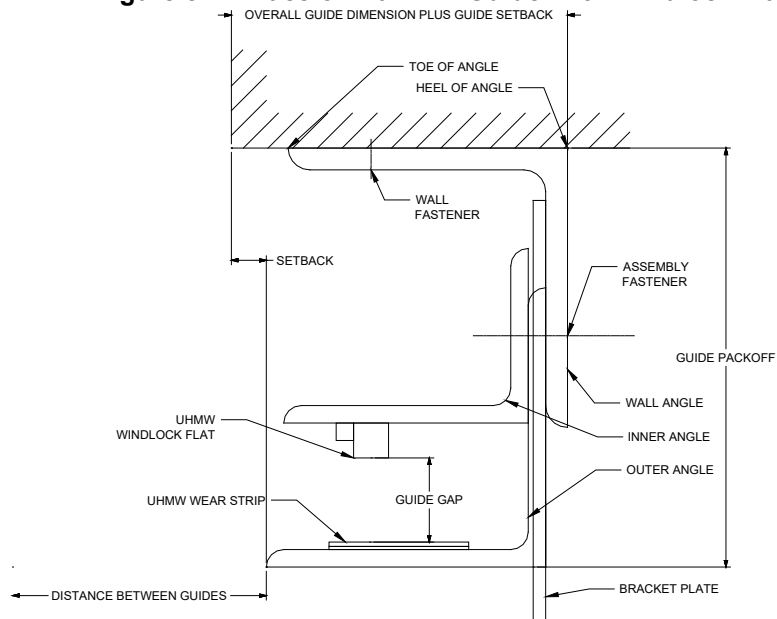

## Section 5 – Guides

1. Remove the bellmouth from the guide by removing the bolts that anchor the bellmouth to the wall angle. Loosen the first bolt closest to the bellmouth on the guide.
2. Certain guide assemblies may have to be disassembled in order to mark the location of the wall fastener mounting holes, and in order to fasten to wall.<sup>2</sup>
  - “Z” guides, with or without windlock flat, may **not** have to be disassembled to install.
  - “E” guides, with or without windlock flat, must be disassembled in order to install the wall angle.
3. Measure the distance from the opening/jamb to the heel of the wall angle (on “E” guides) or the toe of the wall angle (on “Z” guides). This distance is referred to as the “*Overall Guide Dimension plus Guide Setback*”; see **Figures 5.1 - 5.4**. See the job construction drawings for the dimensions.
4. Place mark on the floor at measured location. Check the distance between these marks and compare with the job construction drawing. It will be the “*Distance Between Guides*” plus the “*Overall Guide Dimension plus Guide Setback*” at both jambs.

### NOTICE

If the measurement does not equal the dimensions on the job construction drawings, **STOP**. Check the guide dimensions against those on the job construction drawings to be sure the correct guides are being installed. If so, repeat previous step and re-check.

5. Scribe a plumb line on the wall from the marks on the floor.
6. Place the guide or wall angle against the scribed line, check the top of the guide for level, and mark the location of the wall fastener mounting holes.
7. If the guide is attached to the wall with fasteners, drill mounting holes for the wall fasteners and fasten the guides / wall angle with the hardware provided. Check the job construction drawings for the wall fastener required. Tighten the wall fasteners to the recommended installation torque in the *Torque Specifications Tables* in **Section 12**.
8. If the guide is attached to the wall by welding to structural steel, see the job construction drawings for details on weld location, type, pitch, size, etc.<sup>3</sup>
9. Reassemble inner and outer angles if necessary.
10. Adjust the guide gap if necessary. Guide gap is **critical** and must be verified. Check the job construction drawing to determine what guide gap is required for the unit.
11. Preload the assembly fasteners per the torque recommendations in the *Torque Specifications Tables* in **Section 12**.
12. If guide seal is provided, fasten it to the guide at this time per the guide detail on the job construction drawings.

---

<sup>2</sup> In some cases where there is a mounting member, such as a structural tube (not provided by door manufacturer), the guide may be fastened to the mounting member and then the entire assembly is stood up and installed together. If the guides are too heavy to stand up assembled, they will have to be installed in pieces.

<sup>3</sup> Mi

nimum recommended weld rod: AWS A5.1, Grade E-70.



## Section 5 – Guides

- Between Jambs Units Four-Angle Guide (Figures 5.5):

Figure 5.5 – Between Jambs Four-Angle Guide

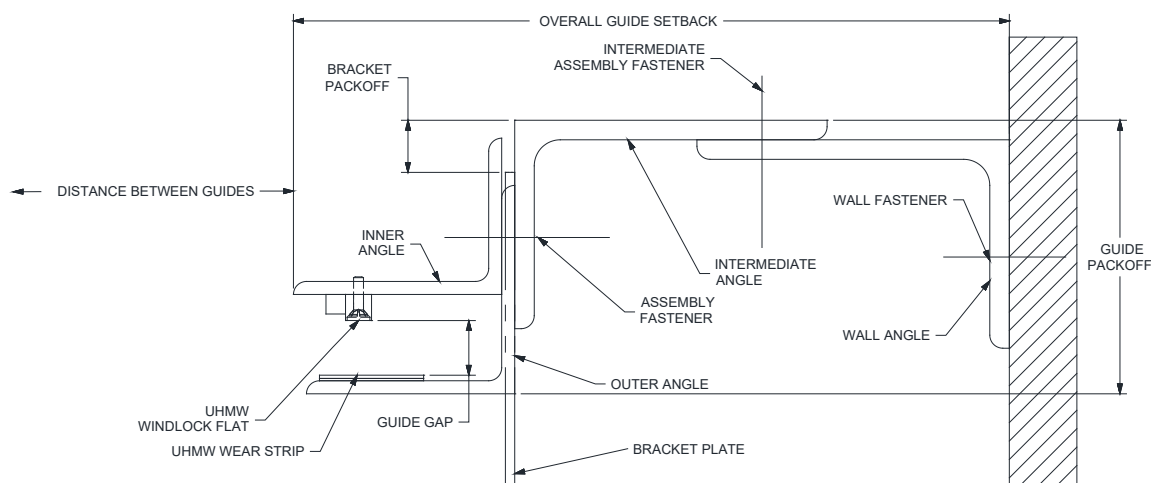

1. Remove the bellmouth from the guide by removing the bolts that anchor the bellmouth to the wall angle. Loosen the first bolt closest to the bellmouth on the guide.
2. Certain guide assemblies may have to be disassembled in order to mark the location of the wall fastener mounting holes, and in order to fasten to the wall. The four angle guide assembly may be too bulky to maneuver or too compact to allow sufficient access for the tool(s) required to apply the necessary torque.<sup>4</sup>
3. Measure the “*Opening Width*”, or the distance between jambs, and compare with the job construction drawings provided. If this distance is not equal to the job construction drawing dimension, **do not proceed!!** Be sure the correct unit is being installed. Contact the project manager.
4. Determine where the fascia of the door will be located with respect to the header / lintel (if one exists) and the jamb.
5. If a header/lintel exists, see the elevation view of the job construction drawings to determine if the door is to be placed against the header as shown below. If so, project a plumb line from the header to the floor. Mark the floor at this location.
6. If a header/lintel does not exist, or if the door is not going to be placed against the header/lintel, contact the project manager to determine where the door will be located. Mark the floor at this location and scribe a plumb line up the jambs.
7. Stand the guide/wall angle up to the wall, holding the bottom of the guide on the mark while making the guide plumb. Mark the location of the wall fastener mounting holes.
8. If possible, check the “*Distance between Guides*”<sup>5</sup> dimension at this time.

<sup>4</sup> In some instances where there is a mounting member, such as a structural tube (not provided by door manufacturer), the guide may be fastened to the mounting member and then the entire assembly is stood up and mounted in place together. If the guides are too heavy to stand up fully assembled, the guides will have to be disassembled to be installed.

<sup>5</sup> The “*Distance between Guides*” dimension may be taken from the tip of the inner or outer angle, depending on which angle extends further into the opening. See the job construction drawing of the guide detail.

## Section 5 – Guides

### NOTICE

If the “*Distance between Guides*” dimension does not equal the dimension on the job construction drawings, **STOP**. Check the guide dimensions against those on the job construction drawings to be sure the correct guide is being installed. If so, repeat the previous steps and check the “*Distance Between Guides*” dimension again.

9. If the guide is attached to the wall with fasteners, drill mounting holes for the wall fasteners and fasten the guides / wall angle with the hardware provided. Check the job construction drawings for the wall fastener required. Tighten the wall fasteners to the recommended installation torque in the *Torque Specifications Tables* in **Section 12**.
10. If the guide is attached to the wall by welding to structural steel, see the job construction drawings for details on weld location, type, pitch, size, etc.<sup>6</sup>
11. Reassemble guides if necessary.
12. Adjust the guide gap if necessary.

### NOTICE

Guide gap is **critical** and must be verified. Check the job construction drawing to determine what guide gap is required for the unit.

13. Preload the assembly fasteners per the torque recommendations in the *Torque Specifications Tables* in **Section 12**

---

<sup>6</sup> Minimum recommended weld rod: AWS A5.1, Grade E-70.

## Section 6 – Barrel and Brackets

### Preparation of the Barrel and Brackets

**Note:** Check to see if a hood support will be required. If so, refer to the “**Hood Support Installation**” section before proceeding to the barrel and brackets.

1. Refer to the job construction drawings to determine the “coil side” of the opening, or the side of the opening on which the coil is to be installed. Then determine which jamb wall is your “operator side”, or side on which the operator is to be installed. The following instructions refer to these directional cues.
2. Unpack the barrel assembly. Note the markings on the barrel, see **Figure 6.1** below.

**Figure 6.1 – Barrel Markings**

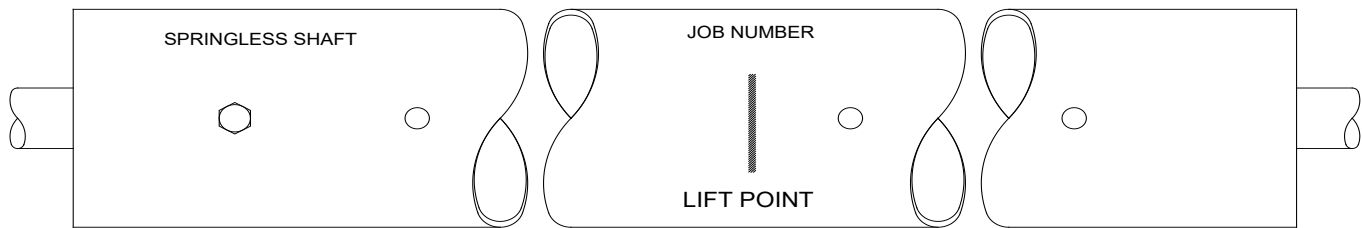

3. Position the barrel assembly on the coil side of the opening with the end marked longer gear end towards the “operator side” of the opening. In order to alleviate the bracket installation, place the barrel assembly on blocks or spacers such that it is elevated off the ground.

**Note:** Choose sufficiently sized blocks. The barrel assembly should be elevated off the ground enough that the brackets can be installed without contacting the floor.

4. Check to make sure the the barrel is marked as *springless*, as shown in **Figure 6.1**. Consult the distributor or the manufacturer if you cannot locate this information.
5. Locate the brackets. Determine the “operator” and “adjustor” brackets by referring to **Figure 6.3**. The “operator” bracket will contain a bearing and holes to mount the operator. The “adjustor” bracket will contain a bearing only.
6. Prior to placing the brackets on the barrel assembly, place the provided spacers on the gear end on each side of the shaft. The spacers will help ensure that the barrel assembly is centered in between the brackets.

**Figure 6.2 – Barrel Spacer Installation**

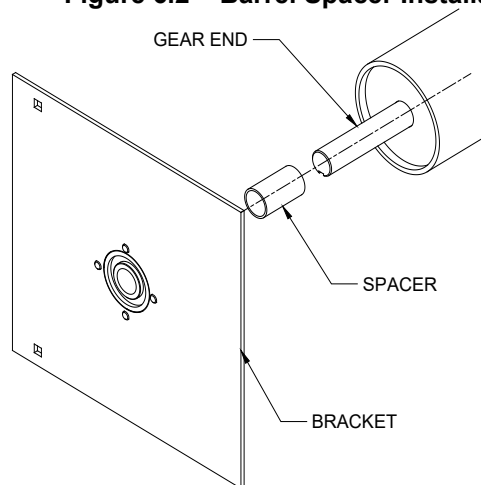

## Section 6 – Barrel and Brackets

- Slide the operator and adjustor brackets over the gear end until the inside face of the bracket is approximately 3 inches from the edge of the outer shaft. Do not tighten the set screws at this point, as you may need to adjust the position of the bracket.
- If installing the operator prior to lifting the barrel and brackets into place, ensure that the “lift point” is adjusted to account for the additional weight of the operator at one end of the shaft. The alignment of the brackets to the wall angles may be easier if the operator is not secured to the bracket, but instead is just placed on the gear end.

Figure 6.3 – Brackets and Barrel Prior to Installation

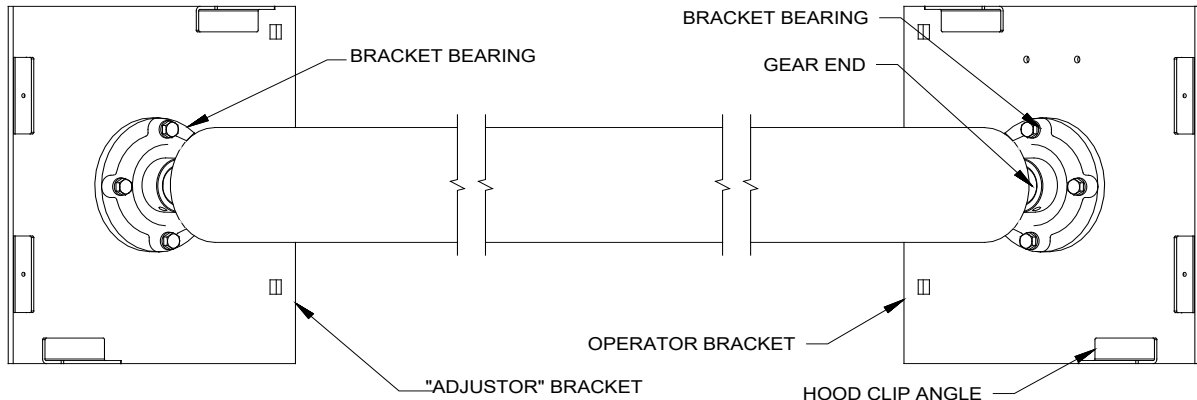

### Hoisting and Installing Barrel Assembly

- The following methods can be used for hoisting them into place:
  - Crane Hoisting:** Place a sling or lifting agent under the barrel assembly at the “lift point” provided on the barrel, see **Figure 6.1**.
  - Forklift Hoisting:** Space the forks evenly under the “lift point” provided on the barrel, see **Figure 6.1**. Ensure that the barrel assembly is positioned close enough to the tips of the forks that the fastening holes in the bracket can be aligned with those of the guides without the forks contacting the wall. Secure the barrel assembly to avoid the slipping off the tip of the forks.

### **WARNING**

The addition of brackets (and operator) may offset the balance slightly from when the “lift point” was marked. Check to make sure the assembly is properly balanced before hoisting.

- Before hoisting, refer to the hardware sheet and ensure that the proper type and quantity of fasteners were provided for the bracket installation. Measure the distance between the brackets and compare that to your wall angles. Readjust the brackets as needed before hoisting.
- Center the barrel assembly between the guides, keeping approximately 2 feet of clearance between the barrel assembly and wall/guides.
- Raise the barrel assembly up to the approximate bracket mounting level. The brackets should be clear of the outer and inner guide angles.

**Note:** Position the brackets in the upright position, with the mounting holes facing the wall, before moving the assembly towards the wall. It may be difficult to rotate the bracket when in close to the wall.

- Slowly maneuver the barrel assembly towards the guide, and align the mounting holes of the brackets with those of the wall angles.
- Insert the specified bolts and snug tighten, see **Figure 6.4**.

## Section 6 – Barrel and Brackets

Figure 6.4 – Bracket Mounting Configuration and Hardware

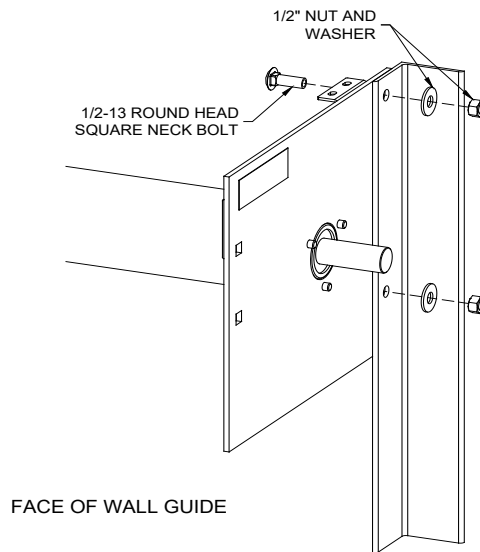

7. Check to see that the barrel is positioned properly between the brackets. That is, so that the proper amount of space is allowed between the barrel and the brackets. Typically the space is equal at both the operator and adjuster side. Adjust as necessary. The set screws in the bearings should be tightened at this time
8. Place a level in the center of the barrel. If the shaft is **not** level:
  - Check the dimensions of the brackets from the top of the bracket to the center of the barrel.
  - Verify that the bracket mounting fasteners are the same distance from the top of the bracket.
    - a. If the dimensions **are not** correct, contact the Service Department.
    - b. If the dimensions **are** correct, the floor may be out of level, causing the bracket mounting holes in the guides to be out of alignment.
9. Fully tighten mounting bolts to the torque specifications in this manual. See *Torque Specification Tables* in **Section 12**.

### NOTICE

Proper pretension of the bracket mounting bolts will benefit the life of the bolts and brackets.

## Section 7 – Motor Operator Installation

1. Unpack the motor operator from the shipping box and retrieve the mounting plates and hardware provided.
2. Refer to the shop drawings in order to understand the operator mounting configuration. See **Figure 7.1** for a vertical mount configuration or **Figure 7.2** for a horizontal mount configuration.
3. Attach the gearbox mounting plate to the operator using the provided hardware. Do not tighten the bolts at this time.
4. Attach the operator mount to the head plate. Do not tighten the bolts at this time.
5. In the unlikely event of the operator needing to be removed for maintenance in the future, anti seize lubricant has been provided. Prior to installation apply the anti seize lubricant to the gear end, Gib key, and inside hub of the operator.
6. Place the Gib key in the keyway of the gear end. Slide the operator over the gear end of Gib key, ensuring the keyways are aligned. The keyways can be aligned by rotating the barrel by hand or utilizing the auxiliary hand chain on the operator.
7. Attach the gearbox mounting plate to the operator mount using the provided vibration isolators and hardware.
8. Align the operator and mounting plates so that the operator hangs freely on the gear end.
9. Tighten all the bolts at this time.
10. Remove the bolt in the front/top of the gearbox housing and install the provided vent plug.

### NOTICE

Installation of the vent plug is critical to safe operation of the operator. Failure to install the vent plug may cause permanent damage to the operator.

Figure 7.1 – Vertical Motor Mount

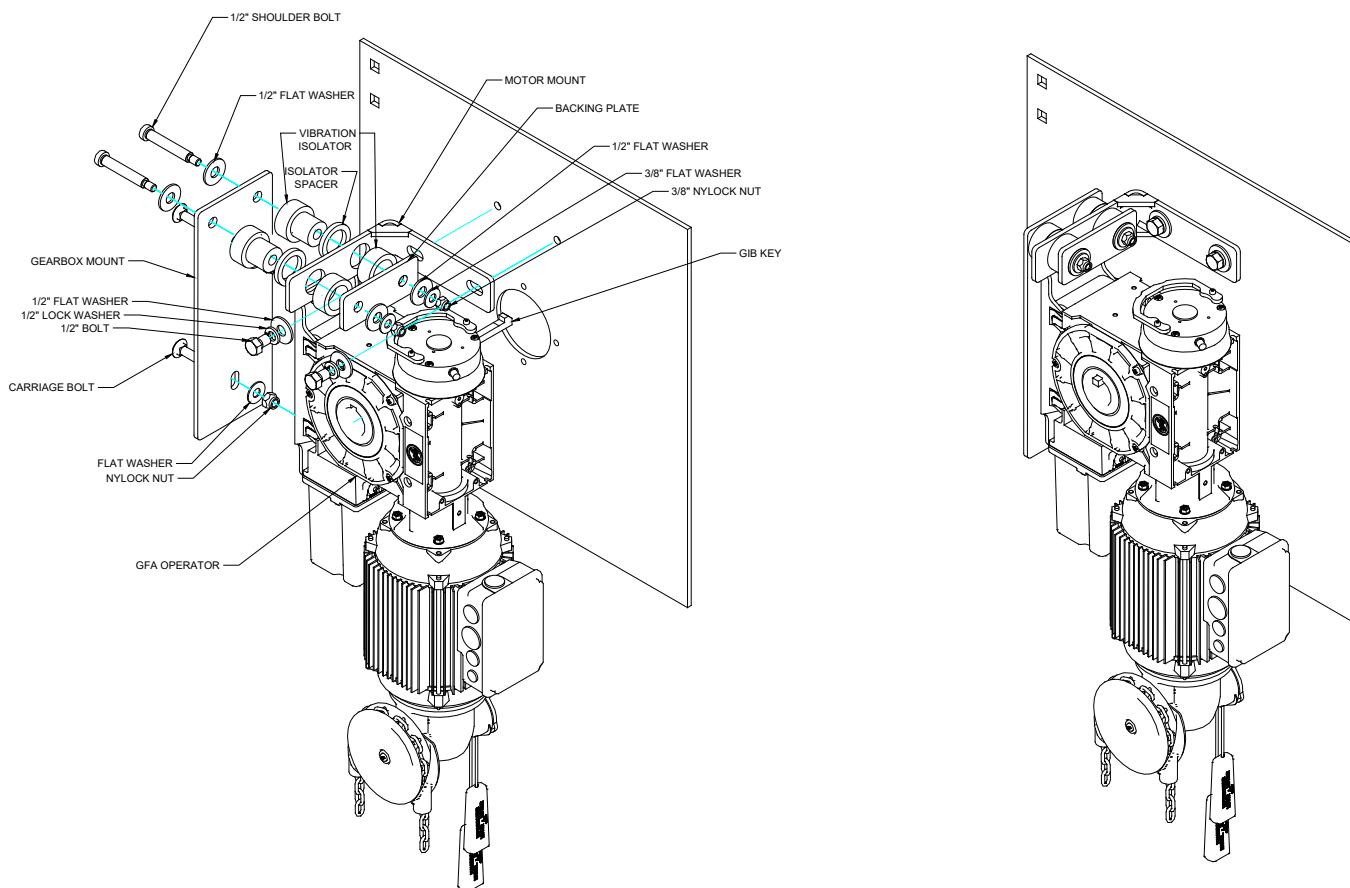

Section 7 – Motor Operator Installation

Figure 7.2 – Horizontal Motor Mount

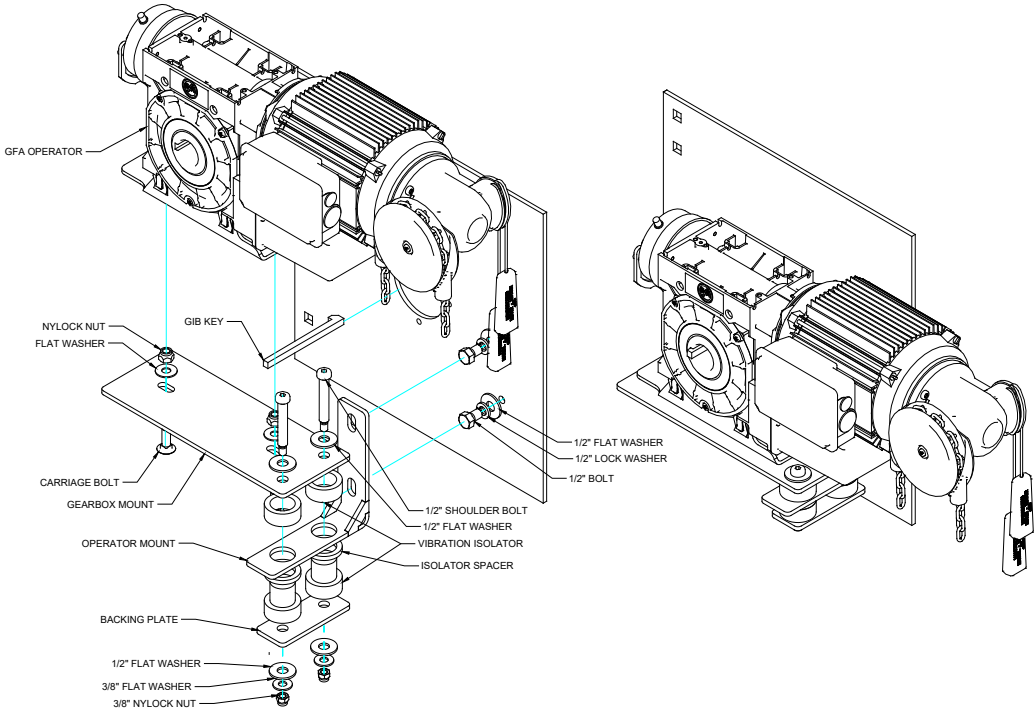

## Section 8 – Curtain Installation

### ▪ Curtain Installation

1. Open the curtain packaging. Leave the plastic straps that keep the curtain from uncoiling in place. It may also be beneficial to leave some of the packaging under the curtain to protect the finish during installation.
2. The coil will be provided with the top of the curtain on the outside, thus leaving the fastening sections exposed. Position the coil on the floor between the guides so that the open end of the fastening sections is facing up and nearer to the wall.
3. If you have not already done so, remove the outer bellmouth from the wall angle or remove the entire outer guide angle.

*Note: If you are only removing the outer bellmouth it is recommended to cover the upper portion of the outer guide angle to prevent damaging the finish on the curtain or guide during installation.*

**Figure 8.1 - Installing the Fastening Section**

4. Locate the curtain attachment hardware provided with the unit. Refer to the job information to ensure you have the correct type and quantity.
5. Lift the coil until it is just below the shaft. Using appropriately rated straps, sling the coil from the shaft as shown in **Figure 8.2**. Remove the plastic strapping securing the coil at this point.
6. Uncoil the curtain enough for the fastening sections to reach the attachment points on the shaft. Fasten them by aligning the fastening section with the hole in the shaft respectively, and fasten using the provided hardware (See **Figure 8.1**). If the curtain is too heavy to uncoil by hand, use the method described in the following step to get the fastening sections in position.
7. Uncoiling a slung curtain using the operator:
  - For units with operators, use the hand chain override feature of the motor to rotate the shaft in the “open” direction.
8. Continue to rotate the shaft, reeling the curtain out of the sling and onto the shaft until the bottom bar reaches the bottom of the bracket.
9. Replace the outer bellmouth/outer guides.
10. Feed the bottom bar into the guides and lower the curtain until the bottom bar is below the header.

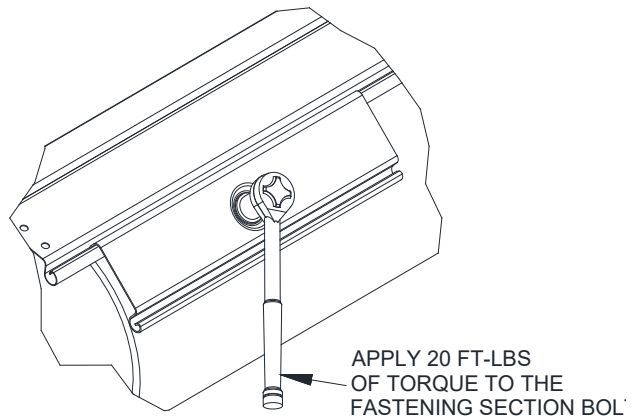



## Section 8 – Curtain Installation

11. Since there is no spring tension holding the curtain open, the curtain may fall if released. If the operator cannot be used to hold the curtain in the open position, place C-clamps or vice grips on the guides just below the bottom bar - *or*- rest the bottom bar on the slings used to hang the shaft in the previous steps to hold the door open.

Figure 8.2 - Slings the Curtain

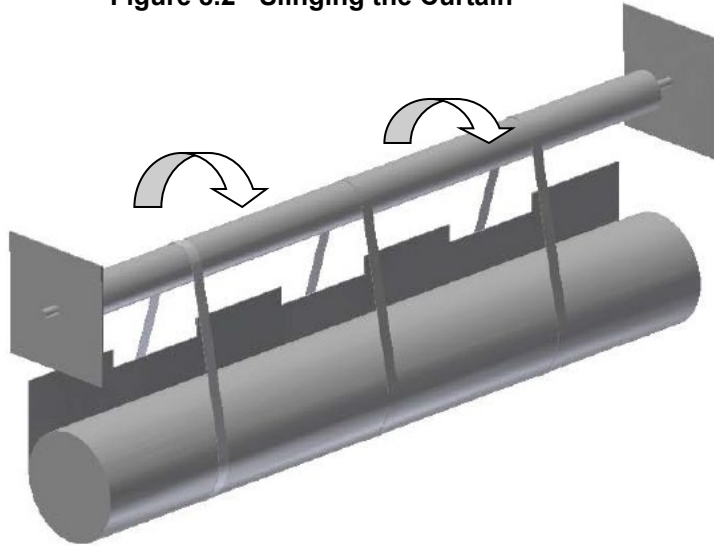

## Section 9 – Sensor Mounting

### ▪ Sensor Mounting

1. Locate all of the sensor mounts (pre-installed with light curtain and photoeye), bottom bar flag, hardware and wiring (pre-wired to the control panel).
2. Ensure that the proper photoeye and light curtain are placed on the proper side of the door. The photoeye transmitter (identified by “SMT” in the part number or the red housing) and the light curtain receiver (identified by “SGR” in the part number) will be placed on the “operator” side of the door. The photoeye receiver (identified by “SMR” in the part number of the yellow housing) and the light curtain transmitter (identified by the “SGT” in the part number) will be placed on the “adjustor” side of the door.
3. Take the plug and play connectors from the control panel and run to each side of the door, with the shorter cable running to the operator side of the door, securing the wire to the sensor mounting angle using the provided wire clips.
4. Attached the plug and play connector to the sensor mounting angle using the provided #12 hardware. The light curtains and photoeyes should also be plugged in at this time.
5. Loosen every other assembly fastener on the guides, started at the fastener closest to the bottom. The fasteners should not be fully removed.
6. Line up the sensor mounting angle with the assembly fasteners and at the same time lift and push back. The sensor mounting angle should drop slightly and rest on the assembly fasteners.
7. Re-tightening the assembly fasteners at this time.
8. Loosen the bottom bar assembly fasteners closest to the guide and insert the provided bottom bar flag as shown in **Figure 9.2**. Re-tighten the fastener at this time

### **⚠ WARNING**

**The bottom bar flag must be installed prior to commissioning the door. Failure to do so is likely to cause permanent damage to the door.**

**Figure 9.1 – Sensor Mounting**

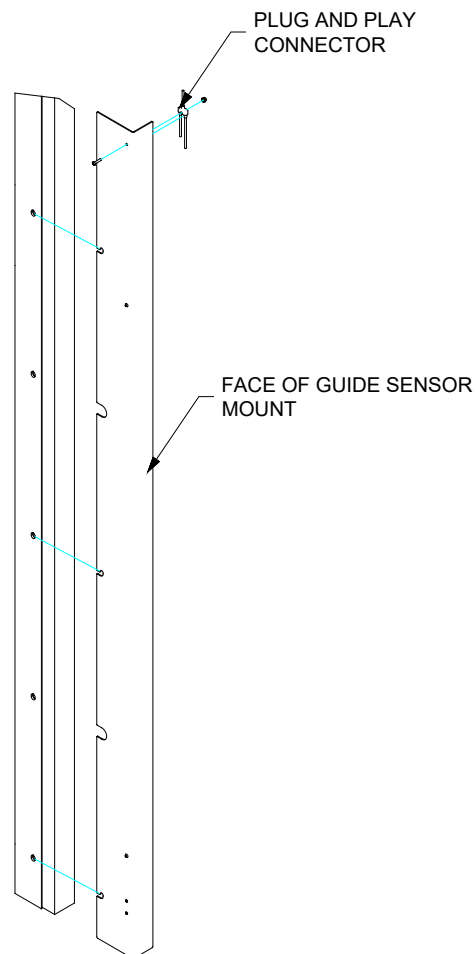

**Figure 9.2 – Bottom Bar Flag**

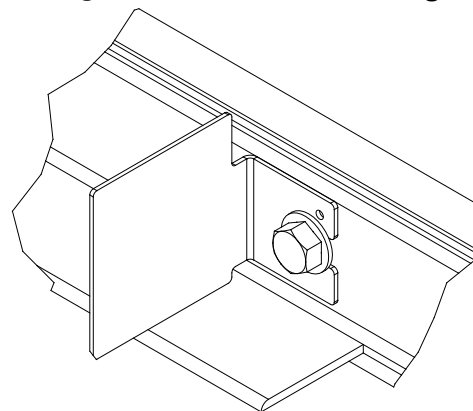

## Section 10 – Lintel Seal

### ▪ "Z" Shaped Seal

Figure 10.1 - "Z" Shaped Lintel Seal Cutout

**Note:** The Lintel Seal should be installed before the hood and fascia, and after all other door components are installed and operational.

1. Clean and inspect the top of the opening where the Lintel Seal will be installed. See shop drawings for details.
2. Make the "A" & "B" cutouts to the ends of the extrusion(s) according to the dimensions on the shop sheet to allow for the guide setbacks and pack-off. (See **Figure 10.1**)
3. Mark and drill the mounting holes in the extrusion. Ensure the mounting holes allow sufficient clearance for the fasteners being used to attach the lintel seal. The mounting holes should be spaced at a maximum of 24 inches apart. Position the holes equally between the front edge of the lintel and the back edge of the extrusion.
4. Place the lintel seal at the bottom of the lintel with the brush contacting the curtain (in the closed position) with the bristles pushed to about a 45-degree angle. (See **Figure 10.2**)

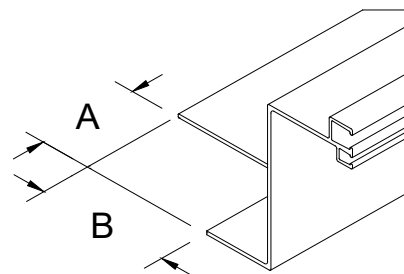
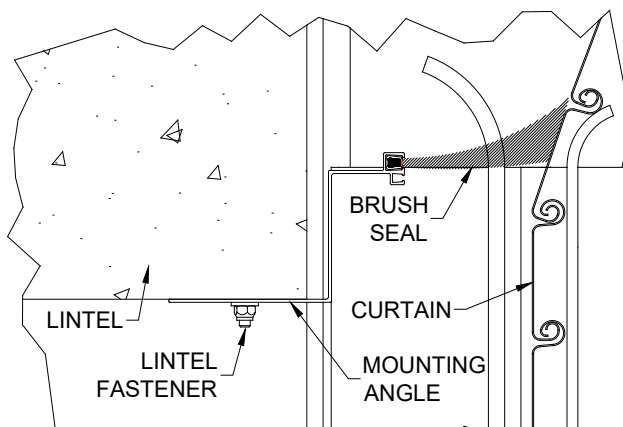

Figure 10.2 - "Z" Shaped Lintel Seal



**Note:** Check the lintel brush for proper contact on the door curtain at the edges and in the middle when the door is both open and closed (mounting extrusion will not sit flush with the corner of the lintel in most cases). On large doors, toward the center, the multi-piece Lintel Seals may have to be angled inward and trimmed on the edges to follow the bow of the door curtain when closed. (Make sure that the brush stays in contact with the door and that the door does not hit the extrusion when it is fully opened.)

5. Once you determine the correct mounting position of the lintel seal, mark the mounting hole locations on the header using the previously drilled holes in the mounting extrusion as a template.
6. Remove the lintel seal and prepare the mounting hole locations for the proper fasteners supplied with the unit.
7. Replace the lintel seal in the opening and insert the fasteners. Make any adjustments the Lintel Seal and properly orient the multi-piece lintel seal (if present) and tighten the fasteners.
8. Operate the door and ensure that the lintel seal sustains sufficient contact with the curtain (The curtain should always touch the Lintel Seal and not hit the extrusion).

## Section 10 – Lintel Seal

### ▪ "L" Shaped Seal

**Note:** The Lintel Seal should be installed before the hood and fascia, and after all other door components are installed and operational.

1. Clean and inspect the top of the opening where the *Lintel Seal* will be installed. See shop drawings for details.
2. Mount the angle to the lintel with the correct fasteners according to the wall construction. (Refer to the job information for the correct location of the angle from the lintel.)

**Note:** Check the lintel brush for proper contact on the door curtain at the edges and in the middle when the door is both open and closed. On large doors, toward the center, the multi-piece Lintel Seals may have to be angled inward and trimmed on the edges to follow the bow of the door curtain when closed. (Make sure that the brush stays in contact with the door and that the door does not hit the extrusion when it is fully opened)

3. Place the brush extrusion in place on the mounting angle so the brush makes contact with the door in the closed position. (Brush should be at about a 45-degree angle) Mark the mounting holes locations. Before removing the lintel seal, scribe a line on the back edge of the extrusion and mounting angle. This will help ensure the lintel seal is replaced in the correct location.
4. Remove the lintel seal. Drill the required pilot/clearance holes in the mounting extrusion. The mounting holes should be spaced at a maximum of 24 inches apart. Position the holes equally between the front and the back edges of the extrusion, or as needed to line up with the mounting angle.
5. Replace the lintel seal on the angle using the scribed line as a guide. Mark the mounting holes on the angle using the previously drilled holes in the mounting extrusion as a template. Remove lintel seal and drill the required pilot/clearance holes.
6. Attach the extrusion to the mounting angle with the proper fasteners.
7. Operate the door and ensure that the lintel seal sustains sufficient contact with the curtain (The curtain should always touch the Lintel Seal and not hit the extrusion).

**Figure 10.3 - "L" Shaped Lintel Seal**

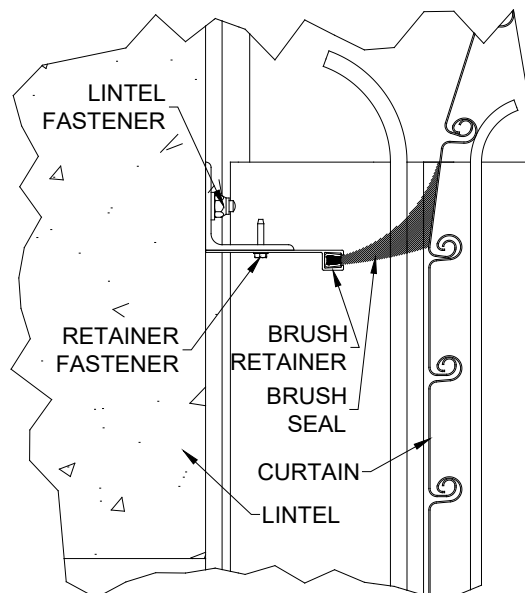

Section 11 – Hood, Fascia, and Covers

▪ **Hood Support installation:**

1. Refer to the job information to determine the type and quantity of hood supports required for your door. Hood supports will be noted on the elevation view of the job construction drawings. See **Figure 11.1** for hood support types.

Figure 11.1 - Hood Supports

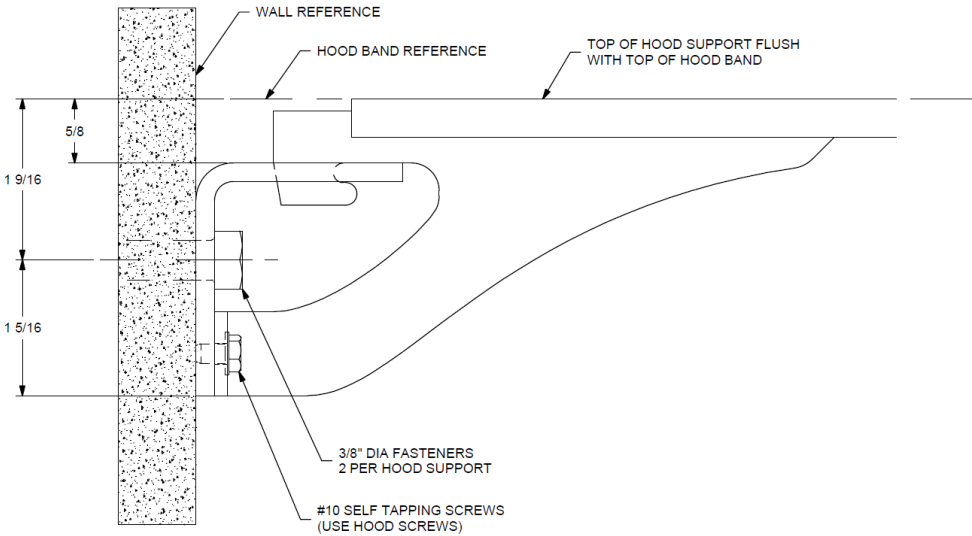

**Note:** See above detail for face of wall units; the wall angle is offset 5/8" from top of hood band to allow hood support to be flush while installing the hood.

## Section 11 – Hood, Fascia, and Covers

2. Determine where the support(s) will be located between the guides.
  - a. If multiple supports are required, see the job construction drawings to determine the centerline of each.
  - b. If a single support is required, it will be located at the center of the unit.
3. Mark a line on the lintel at the centerline of each support.
4. Check the construction at the support locations to be sure it is strong enough to handle the weight of the hood.

**Note:** *If the construction is not strong enough, do not proceed until rectified.*

5. The term "top of coil" refers to the top edges of the brackets or hood band, see **Figure 11.1.1**
  - a. If there is a ceiling at the top of the coil, skip the next step.

**Figure 11.1.1 – Top of Coil**

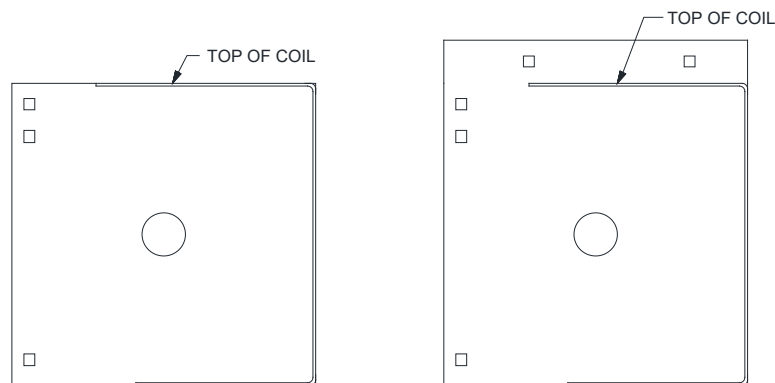

6. Mark a line at the top of the coil at both guides of the unit. Project the lines together to make a continuous line.
  - a. This will help locate the top of the hood support which will keep the hood level.
7. Project a line from the fascia mounting location (fascia mounting channel or fascia side of the tube) from one guide to the other.
8. Mark a line at the support centerline along the fascia line.
9. Prepare the location of the attachment point of the support(s) prior to installing the barrel. This will make installing the support much easier when the time comes to attach it to the lintel/header or ceiling.
  - a. Hold the support in place at the determined location and mark the mounting hole locations.
  - b. Drill holes in the construction and hood support mounting angle.
10. Attach the hood support mounting angle to the lintel/header or ceiling to be sure the mounting holes were located properly.
11. Once the barrel, brackets, curtain are installed, and necessary testing was done on the unit, re-install the hood support.

## Section 11 – Hood, Fascia, and Covers

### ▪ Hood and Fascia installation:

1. Determine what type of hood is provided. See **Figure 11.2** for possible hood configurations. This can be done by:
  - Looking at the brackets and identifying a half-circle shaped flat (D-shaped hood) or straight flats (square or sloped).
  - Looking in the hood box and comparing to the job construction drawings.

**Figure 11.2 – Hood Configurations**

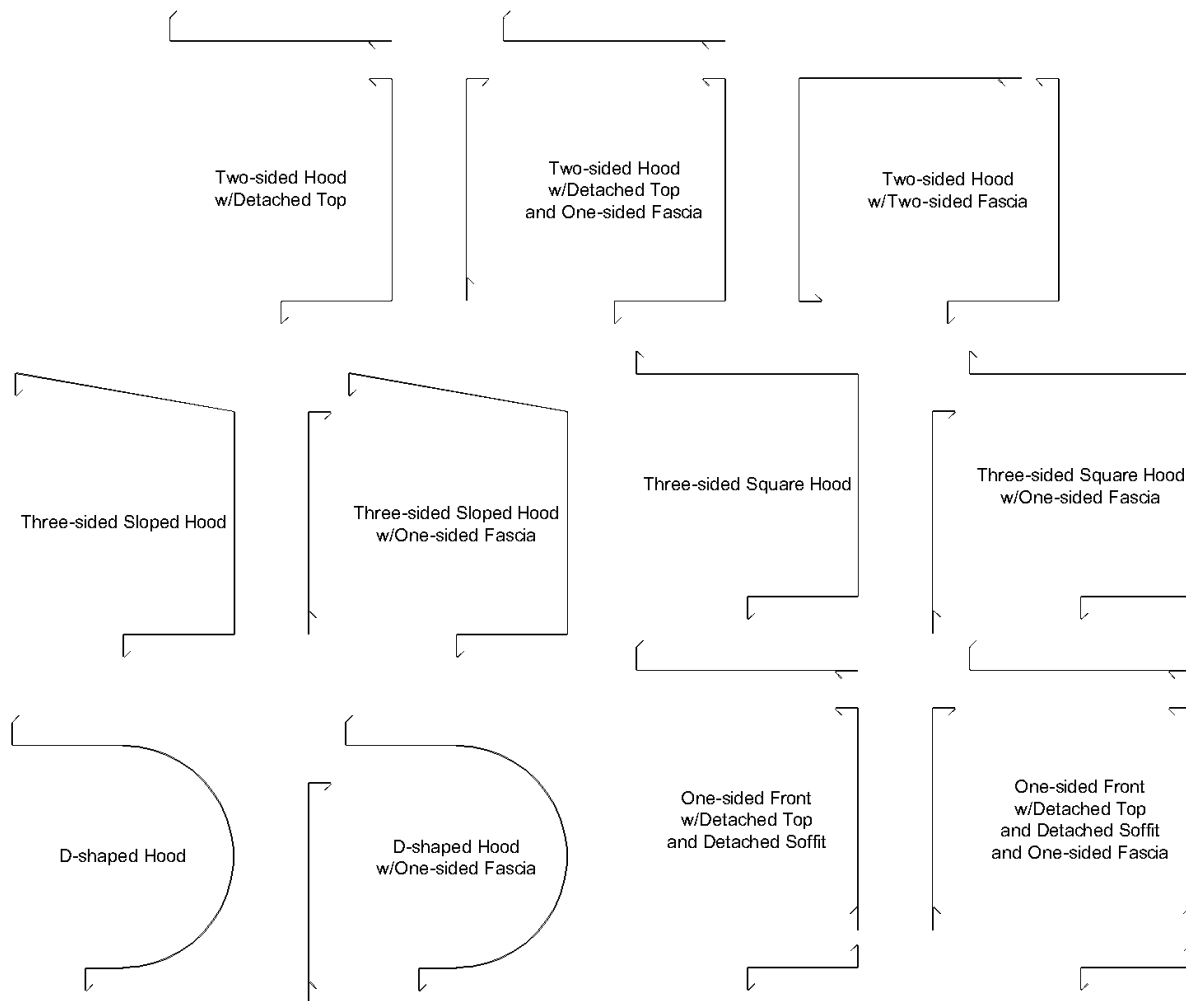

2. If no fascia is included, skip to Step 3.

If a fascia is included, it will be installed first. Fascia fastening varies by job condition but is typically secured to the guides, the brackets, or to the wall. Install the right-most section first, ending in “-R”. Continue leftward adding fascia sections, overlapping the right-hand section by 4”

3. If the hood has more than one section (separate left, right, or center), skip to Step 5.

For single-section hoods, begin with the front-most piece. Install by holding the hood up to the coil area and pushing it against the flats on the brackets. Center the hood so the gap is the same at both

## Section 11 – Hood, Fascia, and Covers

brackets. Pre-drill with a #21 or 5/32" drill in at least one place on every face of the hood, at both the left and right sides. See **Figure 11.4** for recommended fastener locations.

4. After fastening the first hood piece, continue with the detached soffit and top, if included.
5. For hoods with multiple sections, begin with the front-most right-hand hood piece, ending in "-R".

Install by holding the hood up to the coil area and pushing it against the flats on the brackets. Butt the hood piece against the bracket to minimize the gap. Pre-drill with a #21 or 5/32" drill in at least one place on every face of the hood, at both the left and right sides. See **Figure 11.4** for recommended fastener locations.

The hood section should cover the hood support completely (approx. 4"). Temporarily clamp hood section to hood support until the next section is installed.

6. Continue leftward installing sections of the same type of hood piece before starting with the right-most soffit or top pieces. See **Figure 11.4** for an example of the order hood pieces should be installed. No cover is used on the splice between hood sections.

**Figure 11.3 – Multiple Hood Sections**

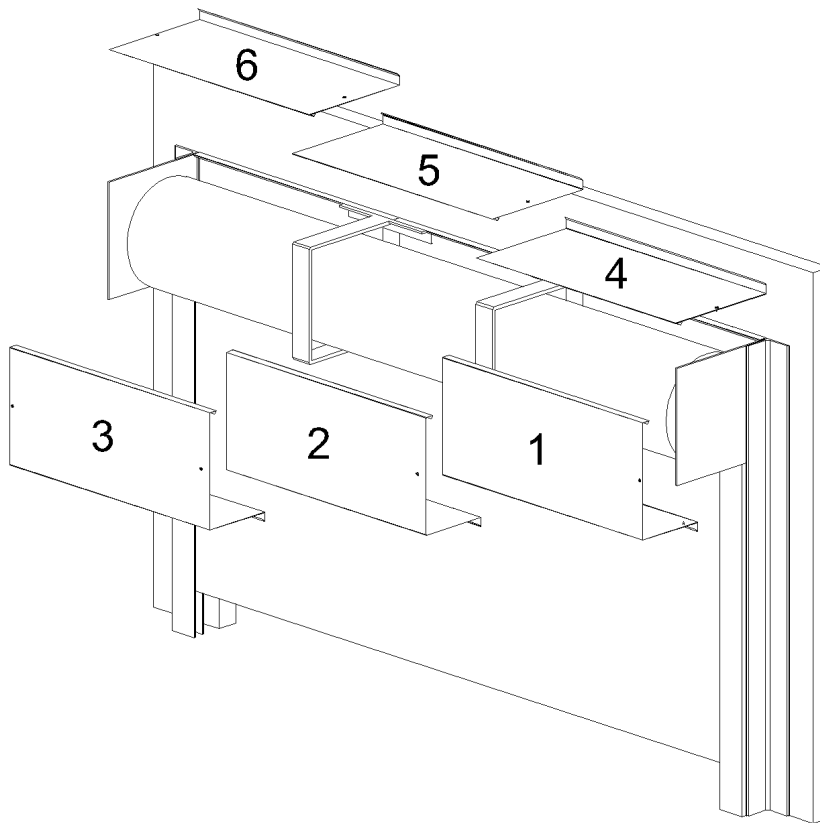



## Section 11 – Hood, Fascia, and Covers

Figure 11.4 – Recommended Fastener Locations

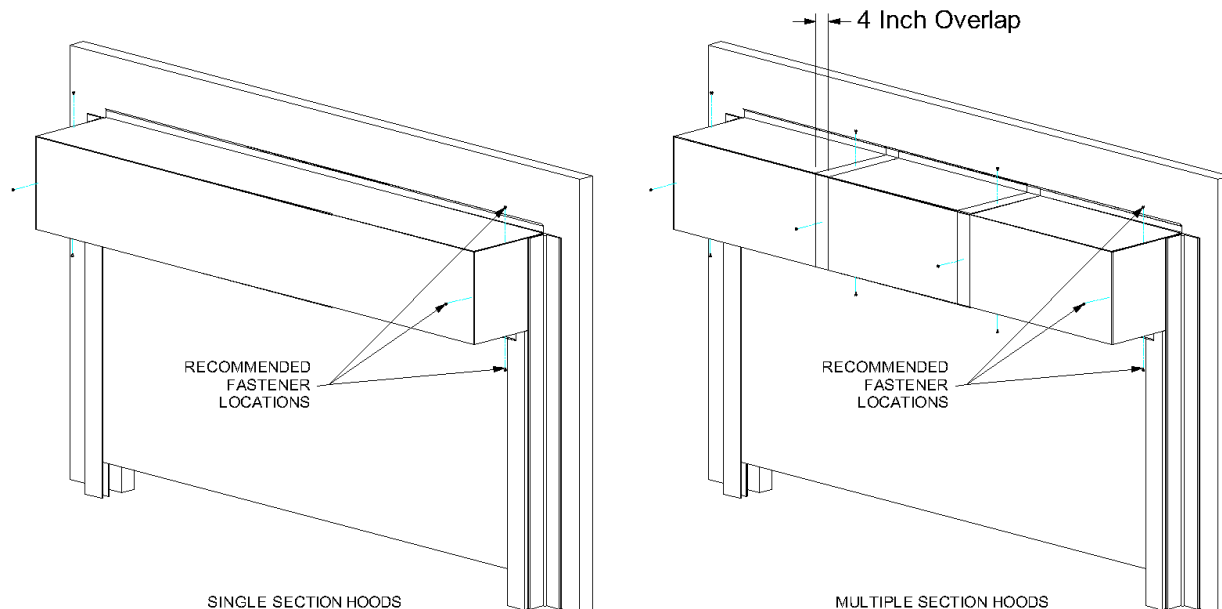

7. If the door is mounted in a weathered or exterior location, caulk the part of the hood that contacts the wall.

▪ **Cover installation:**

1. Once the unit is installed and operating correctly, the covers can be installed.
2. Hood screws may have to be removed and reinstalled to install covers properly.
3. If the cover mounts to the side of the door bracket, pre-drill holes in the bracket to ease installation. A #21 drill size is recommended.
4. If an operator or adjuster cover is provided, individual installation instructions are provided with each cover along with the necessary hardware to attach the cover.
5. Once the cover is installed, operate the door a few more times to be sure there is no interference between the moving components inside the cover and the cover itself.
6. If the door is mounted on the exterior of the building, a bead of silicone sealant should be applied around the entire perimeter of the cover, as it will provide additional protection to the door components.

## Section 12 – Torque Specifications

**Table 12.1 – Torque Recommendations for Guide Assembly and Wall Fasteners**

Bolt size/type	Torque (ft lbs) <sup>a</sup>
1/4-20 Grade 2 steel bolt	6
5/16-18 Black Oxide Socket Cap	25
3/8-16 18-8 stainless steel bolt	20
3/8-16 Grade 2 steel bolt	20
3/8-16 Grade 5 steel bolt	31
1/2-13 Grade 5 steel bolt	75
1/2-13 Grade 8 steel bolt	107
5/8-11 Grade 8 steel bolt	212
3/4-10 Grade 8 steel bolt	376
<sup>a</sup> The recommended torque for steel bolts is based on a plated bolt that has not been lubricated.	

**Table 12.2 - Torque Recommendations for Solid Masonry Wall Anchors**

Anchor Size (nominal)	Manufacturer/Torque (ft lbs) <sup>a</sup>	
	Simpson Wedge-All	Hilti Kwik-Bolt 3
3/8	30	20
1/2	60	40
5/8	90	85
3/4	150	150
<sup>a</sup> Torque values for grout filled block are different, reference bolt manufacturer for these values.		

### Section 13 – Maintenance Schedule

▪ **Maintenance Schedule:**

**Note:** If any of the following problems exist, **do not** operate the door until repaired.

Component	What to look for and how often the components must be inspected:	Weekly	Monthly	Quarterly	What to do if problem exists:
Curtain & Bottom Bar	Are any curtain components damaged (slats, endlocks, etc.)?	X			Contact Service about replacing damaged parts.
	Is bottom bar damaged?	X			Contact Service about replacing damaged parts.
	Are bottom bar fasteners in place and properly tightened?		X		Fasteners must be inspected/replaced and properly tightened.
	Are fasteners attaching curtain to the barrel in place and properly tightened?		X		Fasteners must be inspected/replaced and properly tightened.
	Do you notice any hang-ups, jamming or other problems preventing the door from moving smoothly throughout the opening?	X			Check for external issues, if none exist, contact Service.
	Do you notice any odd or excessive noise when the door is operated?	X			Check for external issues, if none exist, contact Service.
	If there is a bottom seal, is it damaged?		X		Contact Service about replacing damaged parts.
	If there is locking, does it function properly?	X			Check for external issues, if none exist, contact Service.
Brackets	Are brackets plumb and perpendicular with wall?			X	Contact Service.
	Are bracket fasteners in place and properly tightened?			X	Fasteners must be inspected/replaced and properly tightened.
	Do you notice signs of excessive wear on the bearings (i.e. binding, excessive noise, etc.)?		X		If there is a grease fitting, apply grease, if not, contact Service.
Guides	Are wall fasteners in place and properly tightened?		X		Fasteners must be inspected/replaced and properly tightened.
	Are guide assembly fasteners in place and properly tightened?		X		Fasteners must be inspected/replaced and properly tightened.
	Is guide gap dimension correct?		X		Check job construction drawings and adjust gap as required. If job construction drawings are not available, contact Service.
	Are any of the guide parts bent or damaged?		X		Contact Service.
Hood and Fascia	Is hood/fascia dented or damaged?			X	Remove hood/fascia. Repair if possible. If not leave hood/fascia off and contact Service.
	Is curtain rubbing against the hood/fascia?	X			Hood/fascia may have been damaged. Contact Service.
	Is hood/fascia level?			X	Check fasteners, they may be loose or missing. Replace as soon as possible.
	Are guide assembly fasteners in place and properly tightened?		X		Fasteners must be inspected/replaced and properly tightened.
	Is hood support level?			X	Check fasteners, they may be loose or missing. Replace as soon as possible.
Door operation	Does the door require excessive force to open?		X		Check for hang-ups or obstructions. Contact Service.
	If the door contains locking, does the locking mechanism function properly and securely hold the door in the closed position?		X		Check for damage and other external issues. Contact Service.

### Section 13 – Maintenance Schedule

	Does the photoeye function properly?	X			Cut power and check for loose wires. Contact Service for further instruction.
	Does the light curtain function properly?	X			Cut power and check for loose wires. Contact Service for further instruction.
	If there is a sensing edge, does it function properly?	X			Cut power and check for loose wires. Contact Service for further instruction.
Motor Operator	Are the fasteners attaching the motor-to-the mounting bracket, and mounting bracket-to-the door bracket secure?			X	Fasteners must be inspected/replaced and properly tightened. Contact Service for replacement hardware.
	Is the door stopping correctly at the open and closed (as soon as the bottom bar contacts the floor) positions?		X		Limits may have to be adjusted in the motor operator. Refer to the operator owner's manual or contact Service.
	Is the operator functioning normally?		X		Refer to the <i>Operator Manual</i> to diagnose the problem.

## Appendix A – Vinyl Guide Weather Seal

### ▪ Guide Weather Seal Installation Instructions

**NOTICE – A rubber mallet should be used to properly install the seal. DO NOT install the seal using a steel hammer. Use caution when installing the seal below freezing temperatures, as it may crack if handled or installed improperly. If possible store the seal above freezing temperatures until it is installed.**

Figure A.1 – Guide Weather Seal

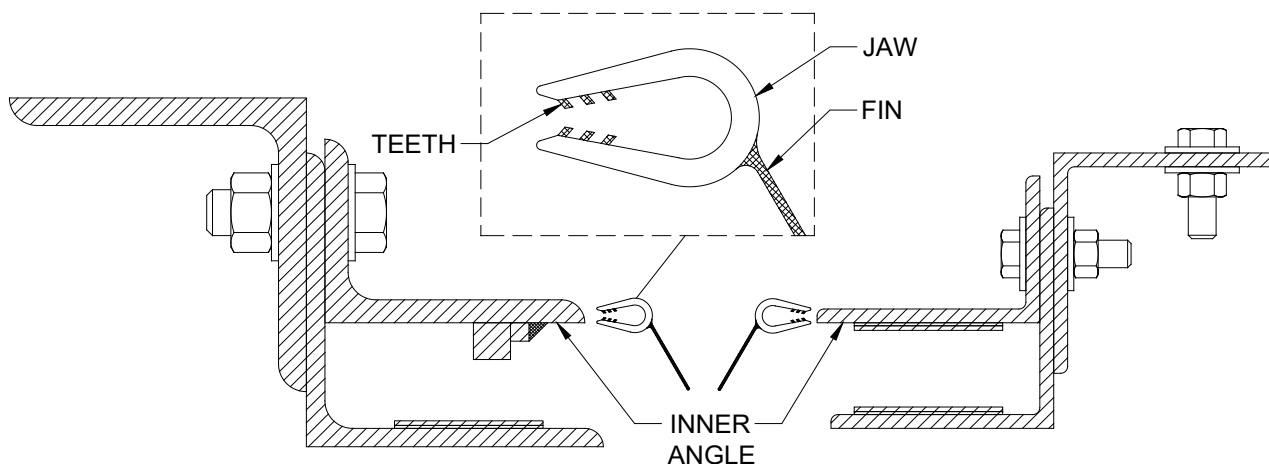

1. The seal should cover from the bottom of the bracket to the bottom of the guide. Check this by either measuring it or holding it up to the guide. If the seal does not cover from the ground to the bottom of the bracket, a spliced section is needed, proceed to step 2. If no splice is required proceed to step 3.

2. If a splice is required, a Craftsman Handi-Cut utility cutter is recommended or a pair of tin snips or other cutting device can be used to cut the seal. Trim the bottom of the upper piece at a 45 degree angle from the jaw through to the fin. Trim the top of the lower piece at a 45 degree angle from the fin and jaw. See adjacent figure for how to trim the seal. Tape or other adhesive can be used to join the spliced weather seal, if desired.

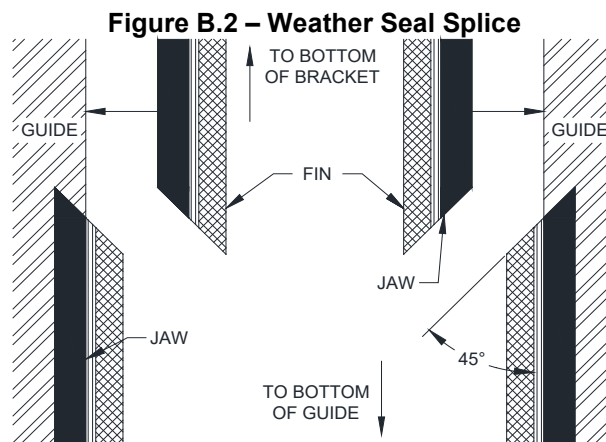

3. Start at the top of the guide and work downward. Be sure that the seal is fully seated on the angle.

**\*\*NOTE - Starting at the bottom may be difficult, as the flexibility of the material will cause it to pull away from the guide as it is being installed.**

4. Run the door up and down a few times to ensure that the seal is installed properly.