

Installation Instructions ***TRUCYCLE™*** ***Service Door and Insulated*** ***Door***

**CORNELLCOOKSON TECHNICAL
SUPPORT DEPARTMENT
("CC TECHNICAL SUPPORT")
800-233-8366**



Section 2 – Safety Check List and Important Warnings	2
Section 3 – Freight Receiving	5
Section 4 – Pre-installation	7
Section 5 – Guides	9
Face Of Wall	9
Between Jamb	12
Section 6 – Barrel and Brackets	14
Preparation	14
Bracket Preparation	15
Hoisting and Installing Barrel Assembly	15
Section 7 - Motor Operator Installation	17
Section 8 – Curtain Installation	19
Section 9 – Sensor Mounting	21
Section 10 – Lintel Seal	23
Z Shape	23
L Shape	24
Section 11 – Hood, Fascia, and Covers	25
Hood Support Installation	25
Hood and Fascia Installation	27
Section 12 – Torque Specifications	30
Section 13 – Maintenance Schedule	32
Appendix A – Vinyl Guide Weather Seal	36

SECTION 2 – SAFETY CHECKLIST AND IMPORTANT WARNINGS

Glossary of Important Terms

Throughout this manual, the following key words are used to alert the reader of potentially hazardous situations, or situations where additional information to successfully perform the procedure is presented:

⚠ DANGER

DANGER is used to indicate a hazardous situation, which, if not avoided, will result in death or serious injury.

⚠ WARNING

WARNING is used to indicate a hazardous situation, which, if no avoided, could result in death or serious injury.

⚠ CAUTION

CAUTION is used to indicate a hazardous situation, which, if not avoided, could result in minor or moderate injury.

NOTICE

NOTICE is used to indicate actions that do not relate to physical injury, but may result in damage to the product or other objects.

IMPORTANT:

IMPORTANT is used to relay information CRITICAL to the successful completion of the procedure.

NOTE: “NOTE” is used to provide additional information to aid in the performance of the procedure or operation of the door, but not necessarily safety related.

THIS SECTION MUST BE READ THIS BEFORE STARTING ANY INSTALLATION

⚠ DANGER

INSTALLATION, REPAIR AND MAINTENANCE OF THIS PRODUCT REQUIRES SUBSTANTIAL KNOWLEDGE AND EXPERIENCE WITH THE INSTALLATION, REPAIR AND MAINTENANCE OF ROLLING DOORS, THEIR PARTS AND SYSTEMS, AND THE RISKS ASSOCIATED WITH THEM.

THIS PRODUCT SHOULD BE INSTALLED, REPAIRED AND MAINTAINED ONLY BY A PROFESSIONAL TRAINED IN ROLLING DOOR INSTALLATION REPAIR AND MAINTENANCE ("PROFESSIONAL INSTALLER(S)"). HAVING SOMEBODY ELSE INSTALL, REPAIR OR MAINTAIN THIS PRODUCT PUTS THEM AND THOSE AROUND THE DOOR IN DANGER OF SERIOUS INJURY OR DEATH.





ALL INSTRUCTIONS AND WARNINGS IN THIS MANUAL MUST BE READ AND UNDERSTOOD BEFORE STARTING ANY INSTALLATION. IF ANY PART OF THIS MANUAL IS UNCLEAR (INCLUDING THIS WARNING) OR IF ADDITIONAL INFORMATION IS NEEDED, THE INDIVIDUAL INSTALLING, REPAIRING OR MAINTAINING THE PRODUCT MUST CONTACT CORNELLCOOKSON'S TECHNICAL SUPPORT DEPARTMENT.

SECTION 2 – SAFETY CHECKLIST AND IMPORTANT WARNINGS

Safety Checklist:

- Review the potential hazards and preventative measures listed below:

Table 2.1 – Potential Hazards and Preventative Measures

Potential Hazard		Preventative Measure
	<p>⚠ DANGER Pinned or crushed by closing door</p>	<ul style="list-style-type: none"> • Keep yourself, others and objects clear of opening while door is in motion. • Do not allow children around the door. • Do not allow children to operate the door. • Do not operate if door becomes jammed, broken or does not operate smoothly. Immediately stop use and contact a Professional Installer for repair.
	<p>⚠ WARNING Struck by adjusting wheel bar while applying spring turns</p>	<ul style="list-style-type: none"> • If door has tension springs, be sure bar is adequate in strength and long enough to apply necessary torque. Refer to “Applying Spring Turns” for specific bar size recommendations. • Make sure bar is fully seated into the adjusting wheel slot before applying pressure. • Use two bars while applying turns to adjusting wheel. • Follow the steps under “Curtain Installation” closely.
	<p>⚠ WARNING Electrical shock.</p>	<ul style="list-style-type: none"> • Make sure electrical operator is properly grounded at all times. • Turn off source power completely prior to servicing motor. • Make sure all wires are clear of any moving or potentially moving parts. • Avoid pinching wires when installing motor cover.
	<p>⚠ WARNING Pinching by moving components.</p>	<ul style="list-style-type: none"> • Make sure motor is turned off and unplugged before working with moving parts (such as roller chain and sprockets, drop-out mechanism, adjusting wheels, etc.). • Locate all possible pinch-points of the unit (such as the drive chain, coil area, bottom bar, etc.). door should be disconnected from power and/or locked down if someone is near or working on these areas.

SECTION 2 – SAFETY CHECKLIST AND IMPORTANT WARNINGS

- **Check the following during installation and before leaving the job site:**
 - a. If the door has tension springs, be sure proper amount of tension is applied to torsion springs in order to properly counterbalance weight of curtain.
 - b. Securely fasten tension adjusting wheel in place with appropriate hardware provided and shown in “Curtain Installation”.
 - c. Check that keys and/or cotter pins have been set in place and fit properly at all sprockets or gears.
 - d. Check that setscrews in each sprocket or gear (one over the key and one offset from the key) have been tightened properly.
 - e. Check all fasteners holding the unit to building structures to ensure correct type have been installed and have correct torque/tightness.
 - f. Check all fasteners used to assemble components of the unit together to ensure correct type have been installed and have the correct torque/tightness.
 - a. Instruct owner or their representative in the proper method of operating and maintaining the door, review all warnings on the door and in this manual, and leave a copy of this manual.

SECTION 3 - FREIGHT RECEIVING

- Upon delivery, carefully check to make sure all components are in undamaged condition.
- If damage to any component has occurred in transit, **do not** proceed with the installation without first receiving authorization from the manufacturer.

NOTICE

Inspect for damage prior to removing packaging. If the installation proceeds with damaged components but without manufacturer authorization, neither the carrier nor the manufacturer shall be responsible for replacing damaged material, any operational issues with the door, or any resulting property damage to the door or the facility or injury to persons.

- **If the installation is stopped due to damage, do the following:**
 1. Take pictures of the damage.
 2. Do not move material from point of delivery to other premises once damaged components are discovered.
 3. If damage is visible prior to removing packaging, do not unpack such component/material until an inspection by the carrier has been completed.
 4. If damage is found while removing contents from packaging, packaging material must be saved until inspection is made.
 5. Container and packaging should be retained by Dealer until inspection is made by carrier's representative.
 6. Have components inspected by carrier's representative within 15 days from date of delivery.
 7. Dealer must obtain a copy of the Inspection Report from carrier and provide to manufacturer.
- **Returning damaged components:**
 1. Obtain permission from carrier to return damaged component(s) to manufacturer's original shipping address.
 2. Route return shipment via identical carrier(s) involved in original shipment.
 3. Notify manufacturer when shipment is returned to manufacturer's plant.
- **Once you have confirmed no damage, verify all components have arrived as soon as practicable, looking for each of the following:**
 1. Job Construction Drawings featuring different views (elevation, section, plan, etc.)
 2. Two (2) Guide Assemblies; check for guide weathering, if included in order.
 3. Barrel Assembly
 4. Curtain Assembly with Bottom Bar attached
 5. Two (2) Bracket Assemblies
 6. Operator (if not attached to bracket)
 7. Operator Cover (if specified or ordered)
 8. Adjusting Wheel (if the barrel assembly contains springs)
 9. Inertia Brake (typically on units with springless barrel assemblies)
 10. Hood and Hood Supports (if specified or ordered)
 11. Hardware
 12. Misc. Items (Reelite, lintel seal, hood baffle, etc.)

SECTION 3 - FREIGHT RECEIVING

13. Verify material/finish/color of components matches what is listed on the job construction drawings and/or what was ordered.

▪ **If the delivery is incomplete, do the following:**

1. Make note on delivery receipt.
2. If inspection is completed while driver is present, obtain driver's signature on note identifying missing component(s).
3. Immediately notify both carrier and Technical Support Department.

SECTION 4 – PRE-INSTALLATION

THESE INSTALLATION INSTRUCTIONS MUST BE READ THOROUGHLY BEFORE STARTING ANY INSTALLATION, REPAIR OR MAINTENANCE.

Manufacturer will not be held responsible for any charges, damage, or injuries caused by any installation, maintenance or repair: (1) that was performed improperly and/or not in accordance with these Installation Instructions; or (2) performed by anyone other than a person with substantial training, knowledge and experience with the installation of rolling doors, their parts and systems, and risks associated with them.

Each unit comes with an individual item number. If the job contains multiple units, be sure to locate all the components for each item and separate each item.

⚠ WARNING

DO NOT interchange parts from another door with this door. Interchanging parts may lead to failure of door components and could cause severe injury including crushing, amputation, internal injuries, and/or head trauma. **ONLY USE AUTHORIZED REPLACEMENT PARTS SPECIFICALLY DESIGNED FOR THIS DOOR.**

▪ **Before Starting:**

- a. Locate the job-specific construction drawings for the unit being installed, Your job-specific drawings are included with the door. If the drawings and this manual provide conflicting instructions, follow the drawings. If you cannot find the drawings or have any questions, call CC Technical Support before beginning.
- b. Check the dimensions of opening against the opening dimensions on the drawings. See **Figure 4.1** below.
- c. **Do not proceed** if the opening dimensions differ from those on the drawings. Check with the manufacturer to be sure the correct door is being installed.
- d. Check the jambs of opening for plumb. Check the head/lintel and floor for level. If the unit is to be free standing (for example, mounted to tubes), check floor and ceiling for level and for adequate mounting areas at top and bottom.
- e. If your guides are embedded, please contact CC Technical Support at 1-800-233-8366 for additional labels to be applied to finished wall.

Note: *The floor may not be level if a pitched bottom bar is specified.*

▪ **Work Area:**

- a. The key to a smooth installation is a clean and well-prepared work environment. Once the components have been inspected and the job construction drawings reviewed, lay out components in order of installation.
- b. The opening for the door should be cleaned and inspected for rough surfaces and construction debris.
- c. Next, mounting hardware supplied with the door should correspond with the surface and construction features of the opening.
 - b. The basic assembly sequence is as follows: guides, barrel with rings or tapped holes, brackets, motor operator (if applicable), curtain, bellmouth, stoppers, weather stripping, hood, and operator/adjustor/idler covers.

SECTION 4 – PRE-INSTALLATION

Figure 4.1 - Opening Dimensions and Designations

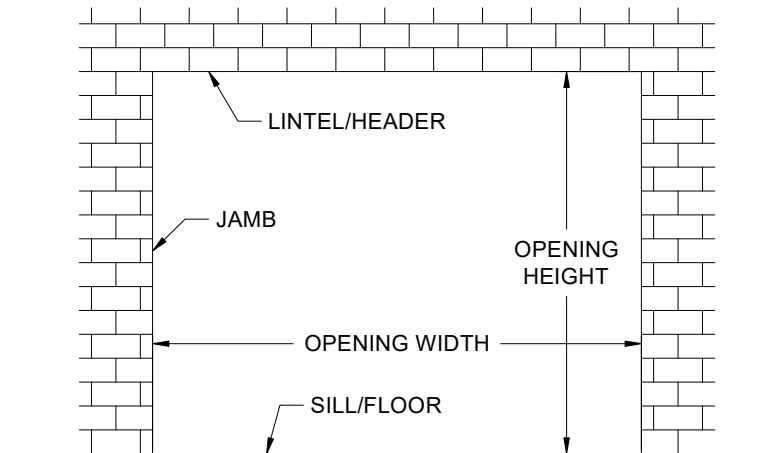

SECTION 5 – GUIDES

▪ Face of Wall Units (Figures 5.1 - 5.4):

Note: Determine which guide assemblies are utilized on the unit from the job construction drawings and compare to the diagrams below.¹

Figure 5.1 – Face of Wall “Z” Guide

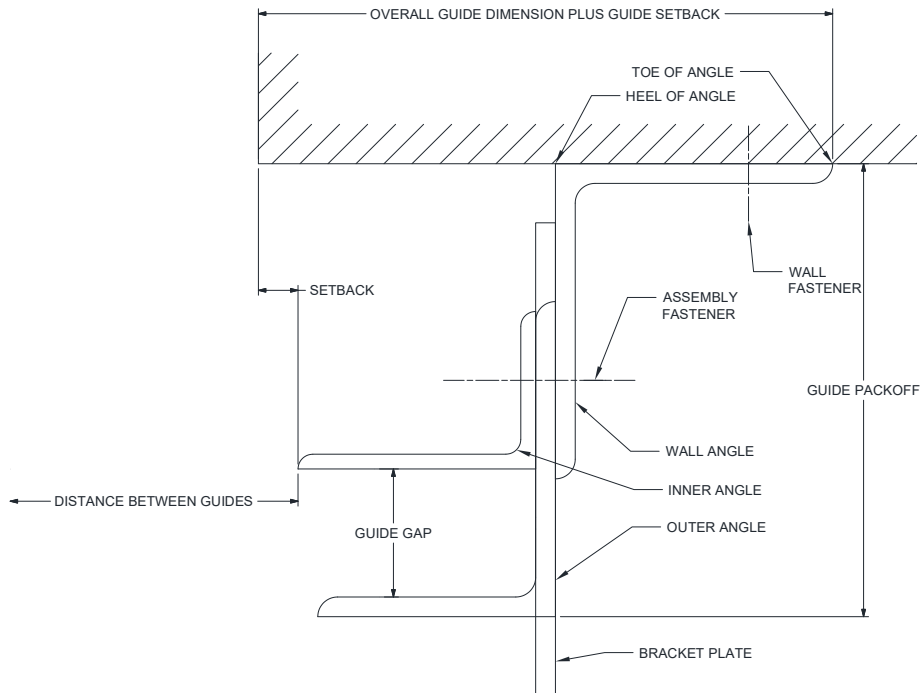
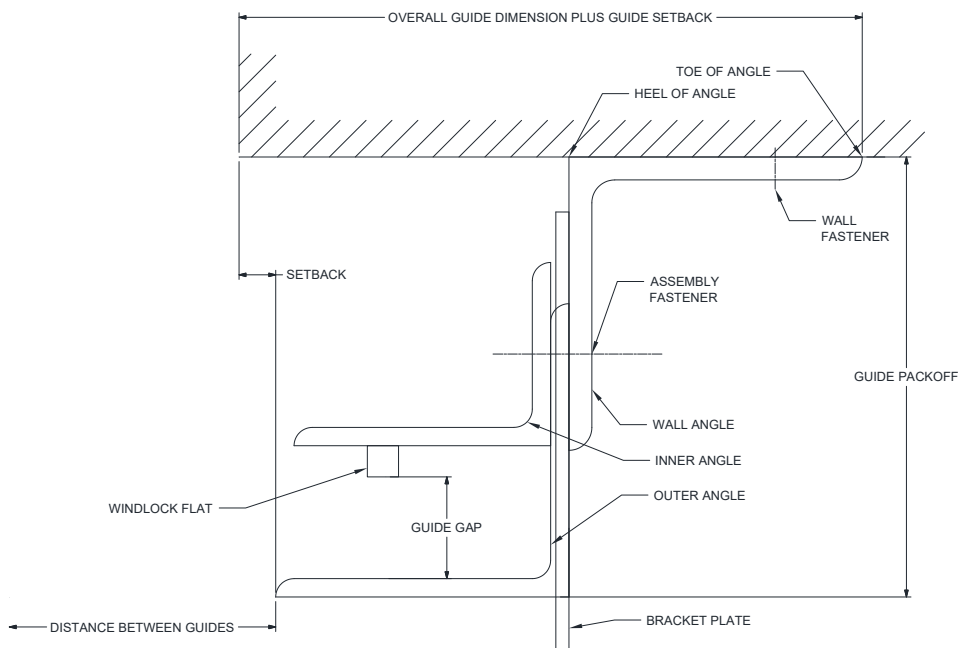

Figure 5.2 – Face of Wall “Z” Guide With Windlock Flat



¹ The guide assembly may differ from the right to left hand side of the unit. In these cases, follow the directions for each particular guide assembly, as well as the job construction drawings provided with the unit.

SECTION 5 – GUIDES

Figure 5.3 – Face of Wall “E” Guide

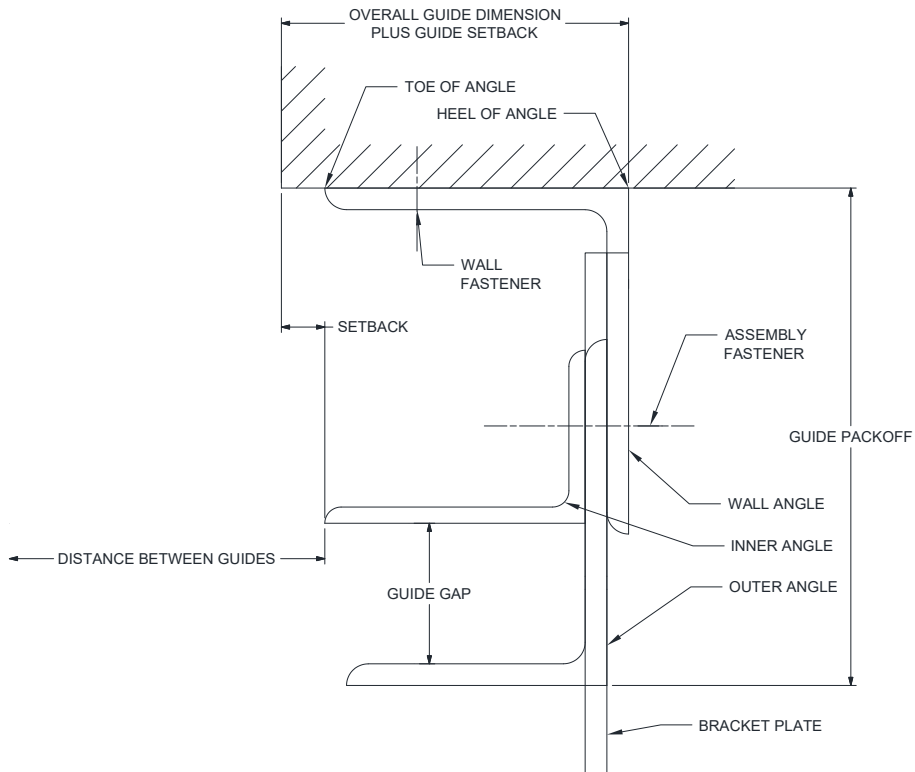
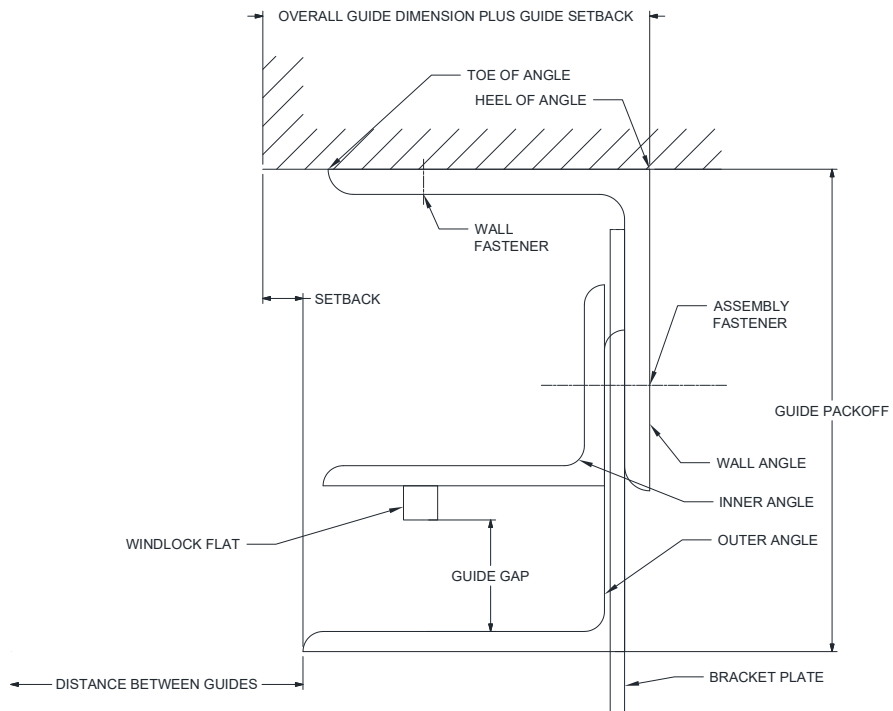

Figure 5.4 – Face of Wall “E” Guide With Windlock Flat



SECTION 5 – GUIDES

1. Remove bellmouth from the guide by removing the bolts anchoring bellmouth to the wall angle. Loosen the first bolt closest to the bellmouth on the guide.
2. Certain guide assemblies may have to be disassembled in order to mark the location of the wall fastener mounting holes, and in order to fasten to wall. ²
 - “Z” guides, with or without windlock flat, may **not** have to be disassembled to install.
 - “E” guides, with or without windlock flat, must be disassembled in order to install the wall angle.
3. Measure the distance from the opening/jamb to the heel of the wall angle (on “E” guides) or the toe of the wall angle (on “Z” guides). This distance is referred to as the “*Overall Guide Dimension plus Guide Setback*”; see **Figures 5.1 - 5.4**. See the job construction drawings for the dimensions. Confirm that the correct unit is being used and contact the project manager for guidance.
4. Place mark on the floor at measured location. Check the distance between these marks and compare with the job construction drawing. It will be the “*Distance Between Guides*” plus the “*Overall Guide Dimension plus Guide Setback*” at both jambs, as marked on Figures 5.1-5.4.

NOTICE

If the measurement does not equal the dimensions on the job construction drawings, **STOP**. Check the guide dimensions against those on the job construction drawings to be sure the correct guides are being installed. If so, repeat previous step and re-check.

5. Scribe a plumb line on the wall from the marks on the floor.
6. Place the guide or wall angle against the scribed line, check the top of the guide for level, and mark the location of the wall fastener mounting holes.
7. If the guide is attached to the wall with fasteners, drill mounting holes for the wall fasteners and fasten the guides / wall angle with the hardware provided. Check the job construction drawings for the wall fastener required. Tighten the wall fasteners to the recommended installation torque in the *Torque Specifications Tables* in **Section 12**.
8. If the guide is attached to the wall by welding to structural steel, see the job construction drawings for details on weld location, type, pitch, size, etc.³
9. Reassemble inner and outer angles, if necessary.
10. Adjust the guide gap, if necessary. Guide gap is **critical** and must be verified. Check the job construction drawing to determine what guide gap is required for the unit.
11. Preload the assembly fasteners per the torque recommendations in the *Torque Specifications Tables* in **Section 12**.
12. If guide seal is provided, fasten it to the guide at this time per the guide detail on the job construction drawings.

² In some cases where there is a mounting member, such as a structural tube (not provided by door manufacturer), the guide may be fastened to the mounting member and then the entire assembly is stood up and installed together. If the guides are too heavy to stand up assembled, they will have to be installed in pieces.

³ Minimum recommended weld rod: AWS A5.1, Grade E-70.

SECTION 5 – GUIDES

- Between Jambs Units Formed Angle Guide (Figures 5.5):

Figure 5.5 – Between Jambs Formed Angle Guide

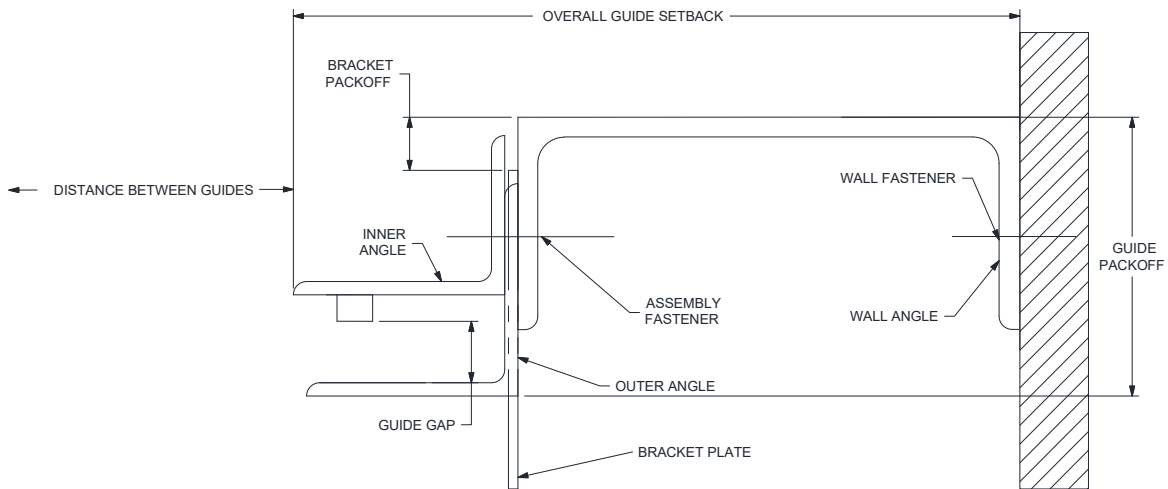

1. Remove the bellmouth from the guide by removing the bolts that anchor the bellmouth to the wall angle. Loosen the first bolt closest to the bellmouth on the guide.
2. Certain guide assemblies may have to be disassembled in order to mark the location of the wall fastener mounting holes, and in order to fasten to the wall. The three angle guide assembly may be too bulky to maneuver or too compact to allow sufficient access for the tool(s) required to apply the necessary torque.⁴
3. Measure the "Opening Width"—the distance between the jambs—and verify it against the dimensions shown in the job construction drawings. If the measured width does not match the specified dimension, **stop installation immediately**. Confirm that the correct unit is being used and contact the project manager for guidance.
4. Determine where the fascia of the door will be located with respect to the header / lintel (if one exists) and the jamb.
5. If a header/lintel exists, see the elevation view of the job construction drawings to determine if the door is to be placed against the header as shown in Section 10. If so, project a plumb line from the header to the floor. Mark the floor at this location.
6. If a header/lintel does not exist, or if the door is not going to be placed against the header/lintel, contact the project manager to determine where the door will be located. Mark the floor at this location and scribe a plumb line up the jambs.
7. Stand the guide/wall angle up to the wall, holding the bottom of the guide on the mark while making the guide plumb. Mark the location of the wall fastener mounting holes.
8. Measure and confirm the "*Distance between Guides*,"⁵ dimension, referenced on the construction drawings.

⁴ In some instances where there is a mounting member, such as a structural tube (not provided by door manufacturer), the guide may be fastened to the mounting member and then the entire assembly is stood up and mounted in place together. If the guides are too heavy to stand up fully assembled, the guides will have to be disassembled to be installed.

⁵ The "Distance between Guides" dimension may be taken from the tip of the inner or outer angle, depending on which angle extends further into the opening. See the job construction drawing of the guide detail.

SECTION 5 – GUIDES

NOTICE

If the “*Distance between Guides*” dimension does not equal the dimension on the job construction drawings, **STOP**. Check the guide dimensions against those on the job construction drawings to be sure the correct guide is being installed. If so, repeat the previous steps and check the “*Distance Between Guides*” dimension again.

9. If the guide is attached to the wall with fasteners, drill mounting holes for the wall fasteners and fasten the guides / wall angle with the hardware provided. Check the job construction drawings for the wall fastener required. Tighten the wall fasteners to the recommended installation torque in the *Torque Specifications Tables* in **Section 12**.
10. If the guide is attached to the wall by welding to structural steel, see the job construction drawings for details on weld location, type, pitch, size, etc.⁶
11. Reassemble guides if necessary.
12. Adjust the guide gap if necessary.

NOTICE

Guide gap is **critical** and must be verified. Check the job construction drawing to determine what guide gap is required for the unit.

13. Preload the assembly fasteners per the torque recommendations in the *Torque Specifications Tables* in **Section 12**

⁶ Minimum recommended weld rod: AWS A5.1, Grade E-70.

SECTION 6 – BARREL, BRACKETS, AND MOTOR OPERATOR INSTALLATION

Preparation of the Barrel and Brackets

Note: Check to see if a hood support will be required. If so, refer to **Section 11, “Hood Support Installation”** before proceeding to the barrel and brackets.

1. Refer to the job construction drawings to determine the “coil side” of the opening (i.e. the side of the opening on which the coil is to be installed). Then determine which jamb wall is your “operator side” (i.e. the side on which the operator is to be installed). The following instructions refer to these directional cues.
2. Unpack the barrel assembly. Note the markings on the barrel, see **Figure 6.1** below.

Figure 6.1 – Barrel Markings

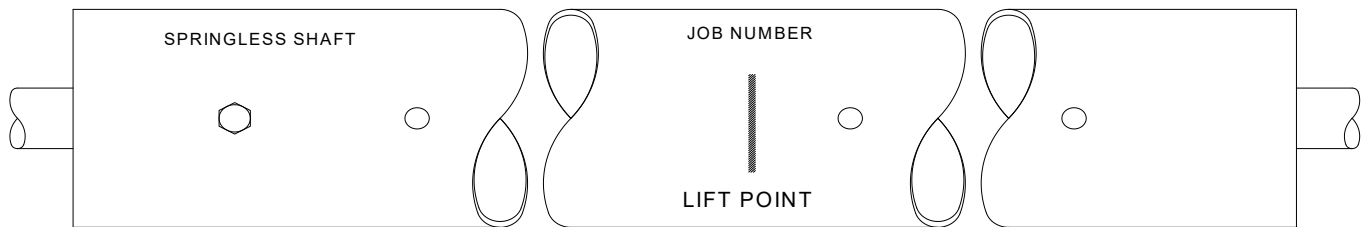

3. Position the barrel assembly on the coil side of the opening, orienting the end marked “longer gear end” toward the operator side. To facilitate bracket installation, support the barrel assembly on blocks or spacers so it is elevated off the floor.

Note: Choose sufficiently sized blocks. The barrel assembly should be elevated off the ground enough that the brackets can be installed without contacting the floor.

4. Check to make sure the barrel is marked as *springless*, as shown in **Figure 6.1**. Consult the distributor or the manufacturer if you cannot locate this information.
5. Locate the brackets. Determine the “operator” and “adjustor” brackets by referring to **Figure 6.3**. The “operator” bracket will contain a bearing and holes to mount the operator. The “adjustor” bracket will contain a bearing only.
6. Prior to placing the brackets on the barrel assembly, place the provided spacers on the gear end on each side of the shaft. The spacers will help ensure that the barrel assembly is centered in between the brackets.

Figure 6.2 – Barrel Spacer Installation

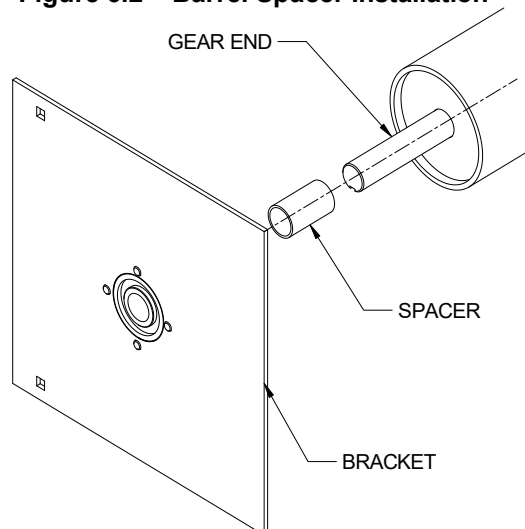

SECTION 6 – BARREL, BRACKETS, AND MOTOR OPERATOR INSTALLATION

- Slide the operator and adjustor brackets onto the gear end of the shaft. Position the brackets so that the inner face is approximately 3 in. from the outer shaft edge for 6-inch shafts, and 4 in. from the outer shaft edge for 8-inch shafts. Do not tighten the set screws at this time, as bracket position adjustment may be required.
- If installing the operator prior to lifting the barrel and brackets into place, ensure that the “lift point” is adjusted to account for the additional weight of the operator at one end of the shaft. The alignment of the brackets to the wall angles may be easier if the operator is not secured to the bracket, but instead is just placed on the gear end.

Figure 6.3 – Brackets and Barrel Prior to Installation

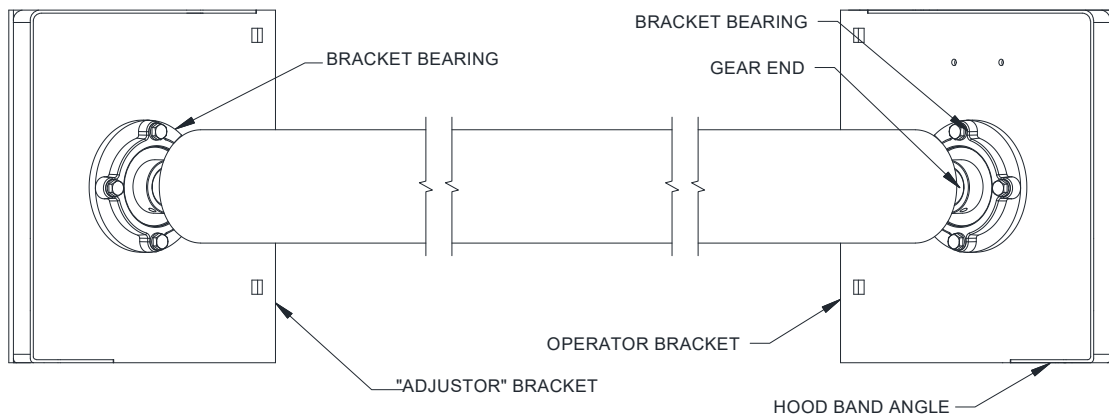

▪ Hoisting and Installing Barrel Assembly

- The following methods can be used for hoisting them into place:
 - Crane Hoisting:** Place a sling or lifting agent under the barrel assembly at the “lift point” provided on the barrel (see **Figure 6.1**).
 - Forklift Hoisting:** Space the forks evenly under the “lift point” provided on the barrel (see **Figure 6.1**). Ensure that the barrel assembly is positioned close enough to the tips of the forks that the fastening holes in the bracket can be aligned with those of the guides without the forks contacting the wall. Secure the barrel assembly to avoid the slipping off the tip of the forks.

⚠ WARNING

The addition of brackets (and operator) may offset the balance slightly from when the “lift point” was marked. Check to make sure the assembly is properly balanced before hoisting.

- Before hoisting, refer to the hardware sheet and ensure that the proper type and quantity of fasteners were provided for the bracket installation. Measure the distance between the brackets and compare that to your wall angles. Readjust the brackets as needed before hoisting.
- Center the barrel assembly between the guides, keeping approximately 2 feet of clearance between the barrel assembly and wall/guides.
- Raise the barrel assembly up to the approximate bracket mounting level. The brackets should be clear of the outer and inner guide angles.

Note: Position the brackets in the upright position with the mounting holes facing the wall before moving the assembly towards the wall. It may be difficult to rotate the bracket when in close to the wall.

- Slowly maneuver the barrel assembly towards the guide and align the mounting holes of the brackets with those of the wall angles.
- Insert the specified bolts and snug tighten (see **Figure 6.4**).

SECTION 6 – BARREL, BRACKETS, AND MOTOR OPERATOR INSTALLATION

Figure 6.4 – Bracket Mounting Configuration and Hardware

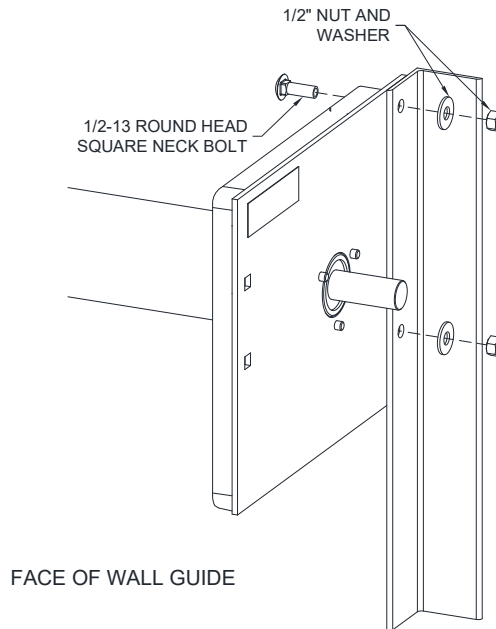

7. Check to see that the barrel is positioned properly between the brackets. That is, so that the proper amount of space is allowed between the barrel and the brackets. Typically, the space is equal at both the operator and adjuster side. Adjust as necessary. The set screws in the bearings should be tightened at this time
8. Place a level in the center of the barrel. If the shaft is **not** level:
 - Check the dimensions of the brackets from the top of the bracket to the center of the barrel.
 - Verify that the bracket mounting fasteners are the same distance from the top of the bracket.
 - a. If the dimensions **are not** correct, contact the CC Technical Support.
 - b. If the dimensions **are** correct, the floor may be out of level, causing the bracket mounting holes in the guides to be out of alignment.
9. Fully tighten mounting bolts to the torque specifications in this manual (see *Torque Specification Tables* in **Section 12**).

NOTICE

Proper pretension of the bracket mounting bolts will benefit the life of the bolts and brackets.

SECTION 7 – MOTOR OPERATOR

▪ Direct Drive Operator

1. Unlatch the crate and remove the top cover as shown in **Figure 7.1**. Each crate includes the operator assembly, mounting hardware, vent plug, and gib key.
2. Prepare to lift the operator by routing a standard 2-inch lifting strap around the unit, positioned between the gearbox and motor.
3. With the strap in place, carefully lift the operator using the strap, ensuring it remains balanced and stable. Loosen the screws securing the operator and remove the crate bottom.
4. Determine the required operator-hand orientation by referring to the construction drawings. All operators are shipped with motor mounting brackets configured for right-hand (RH) operation. For left-hand (LH) operation, rotate the motor bracket 180 degrees as shown in **Figures 7.2** and **7.4**.
5. Before mounting the operator onto the shaft, apply the supplied anti-seize lubricant to the gear end of the shaft, the gib key, and the internal hub surface of the operator.
6. Insert the gib key into the keyway on the gear end. The extended portion of the key must face the motor bracket, as illustrated in **Figure 7.5**.
7. Align the keyways on the shaft and operator hub as shown in **Figure 7.3**. This can be done by manually rotating the barrel or by using the auxiliary hand chain on the operator.
8. Slide the motor onto the shaft by positioning the operator and mounting bracket so that the operator hangs freely from the gearbox end without binding or interference.
9. Secure the motor mount to the mounting plate using the two provided 1/2" hex bolts and washers. If additional adjustment is needed, use the slotted holes in the bracket's flat plate to adjust the motor position and ensure a smooth, unobstructed fit.
10. While holding the motor level, torque all mounting bolts to the specifications listed in **Table 12.1**.
11. Rotate the gearbox until the top/front bolt is at the highest vertical position. Remove this bolt and install the provided vent plug in its place, as shown in **Figure 7.6**. This step must be performed with the bolt at the top to prevent oil from spilling.

NOTICE

Installation of the vent plug is critical to safe operation of the operator. Failure to install the vent plug may cause permanent damage to the operator.

Figure 7.1 – Operator Unboxing

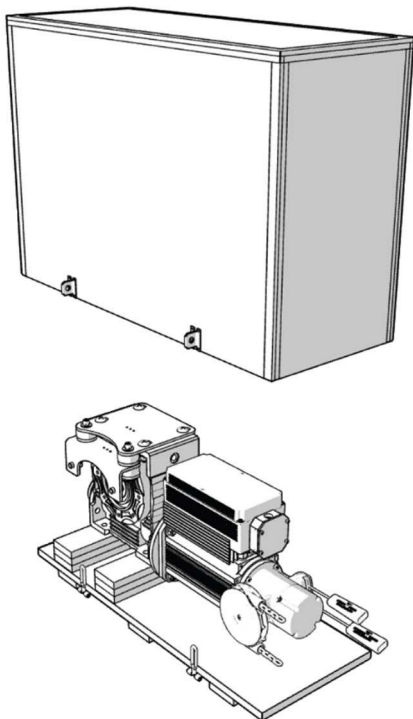
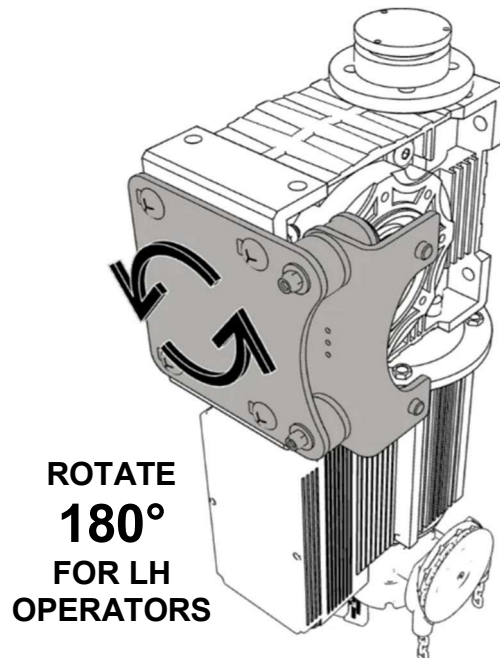

Figure 7.2 – Motor Bracket Mounting



SECTION 7 – MOTOR OPERATOR

Figure 7.3 – Motor To Shaft Mounting

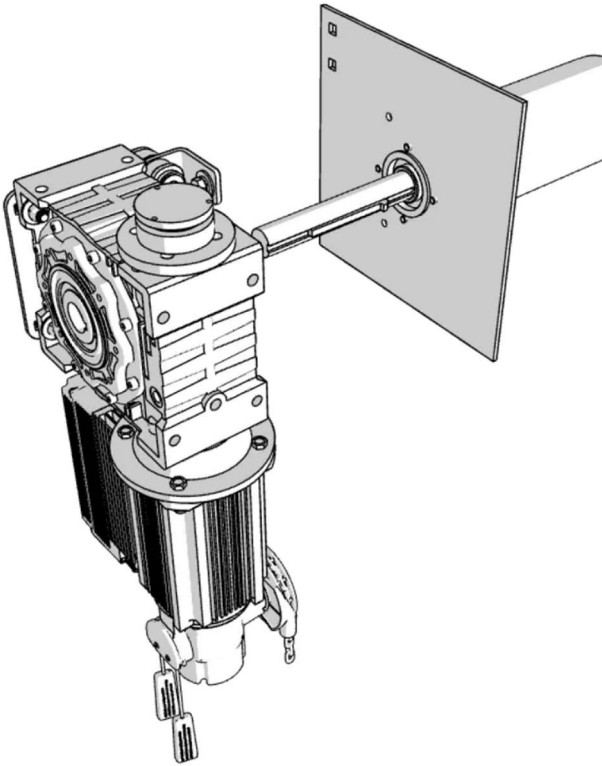

Figure 7.4 – Motor Mount Installation

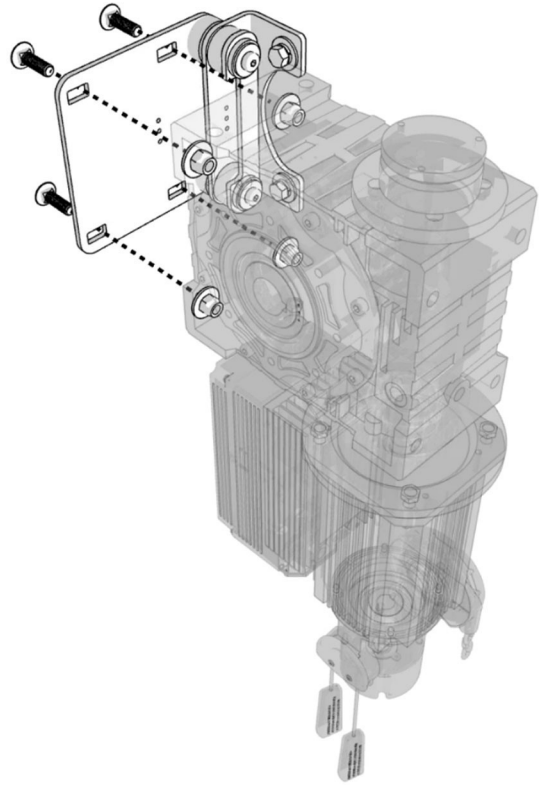

Figure 7.5 – Gib Key Orientation

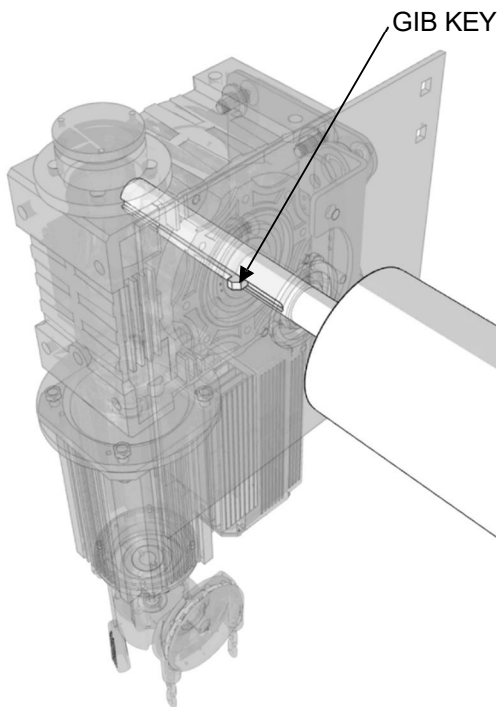
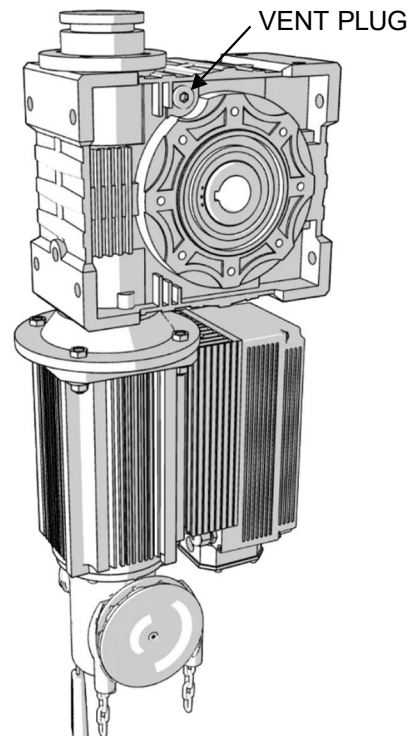

Figure 7.6 – Vent Plug



SECTION 8 – CURTAIN INSTALLATION

▪ Curtain Installation

1. Open the curtain packaging. Leave the plastic straps that keep the curtain from uncoiling in place. It may also be beneficial to leave some of the packaging under the curtain to protect the finish during installation.
2. The coil will be provided with the top of the curtain on the outside, thus leaving the fastening sections exposed. Position the coil on the floor between the guides so that the open end of the fastening sections is facing up and nearer to the wall.
3. If you have not already done so, remove the outer bellmouth from the wall angle or remove the entire outer guide angle.

Note: *If you are only removing the outer bellmouth, it is recommended to cover the upper portion of the outer guide angle to prevent damaging the finish on the curtain or guide during installation.*

Figure 8.1 - Installing the Fastening Section

4. Locate the curtain attachment hardware provided with the unit. Refer to the job hardware sheet information to ensure you have the correct type and quantity.
5. To prevent the coil from falling and causing serious injury or death, you must use lifting straps rated for the coil's full weight, which is specified on your job construction drawings or shipping documents. After confirming your straps are properly rated and free of damage, lift the coil, sling it from the shaft as shown in **Figure 8.2**, and only then cut the plastic shipping straps.
6. Uncoil the curtain enough for the fastening sections to reach the attachment points on the shaft. Fasten them by aligning the fastening section with the hole in the shaft respectively, and fasten using the provided hardware (See **Figure 8.1**). If the curtain is too heavy to uncoil by hand, use the method described in the following step to get the fastening sections in position.
7. Uncoiling a slung curtain using the operator:
 - For units with operators, use the hand chain override feature of the motor to rotate the shaft in the "open" direction.
8. Continue to rotate the shaft, reeling the curtain out of the sling and onto the shaft until the bottom bar reaches the bottom of the bracket.
9. Replace the outer bellmouth/outer guides.
10. Feed the bottom bar into the guides and lower the curtain until the bottom bar is below the header.

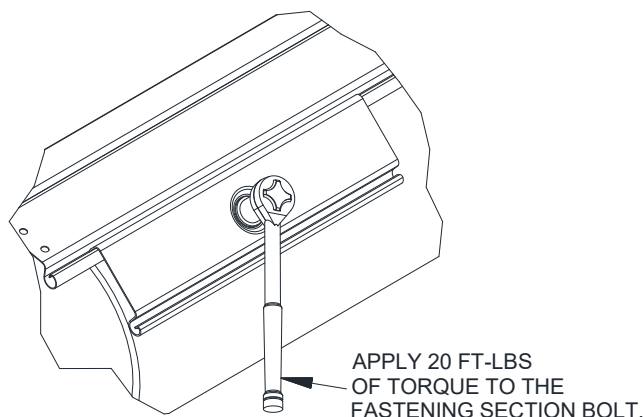

SECTION 8 – CURTAIN INSTALLATION

11. Since there is no spring tension holding the curtain open, the curtain may fall if released. If the operator cannot be used to hold the curtain in the open position, place C-clamps or vice grips on the guides just below the bottom bar - or - rest the bottom bar on the slings used to hang the shaft in the previous steps to hold the door open.

Figure 8.2 - Slings the Curtain

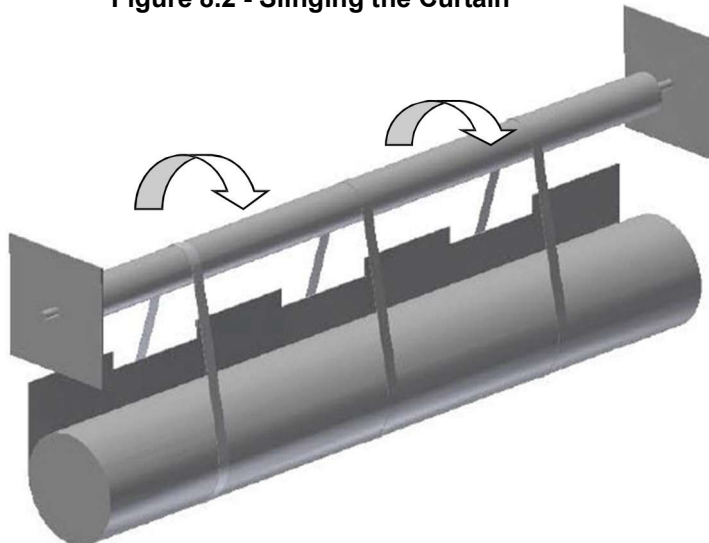

⚠ WARNING

To prevent the unsupported curtain from falling and causing serious injury or death, you must first secure it in the open position using C-clamps or support slings.

SECTION 9 – SENSOR MOUNTING

▪ Sensor Mounting – Standard Installation (Photoeyes Only)

Note: Photoeyes are standard and may be mounted directly to the wall or to the door guides. Sensor mounting angles and bottom bar flags are not applicable in this configuration. Photoeye placement is non-directional and may be installed on either side of the door.

1. Locate the photoeyes and associated mounting hardware.
2. Install the photoeyes on either side of the door, mounting directly to the wall or guide surface. Side selection is not critical for standard operation.
3. Route the photoeye cables from each unit to the control panel located on the operator side of the door. Extend the wiring as needed to span the full door opening, ensuring proper cable management and protection from mechanical interference.
4. Secure the wiring using appropriate fasteners or clips. Terminate the photoeye connections at the controller by plugging into the designated **PE1** and **PE2** ports shown in **Figure 9.1**.

Figure 9.1 – Photoeye Controller Connection

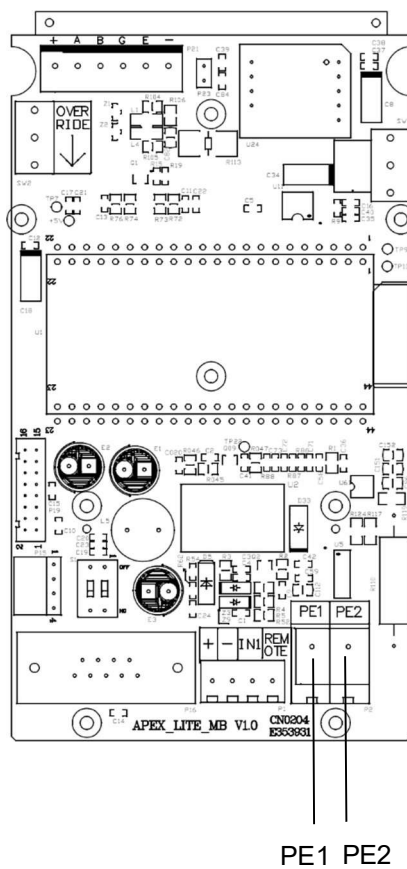

SECTION 9 – SENSOR MOUNTING

▪ Sensor Mounting – Optional Installation – Telco Light Curtains with Photoeyes

Note: If light curtains are selected, Telco photoeyes are used and both photoeyes and light curtains are mounted to the sensor angle. Sensor mounts and bottom bar flags must be installed.

1. Locate the sensor mounts (pre-installed with Telco photoeyes and light curtains), bottom bar flag, hardware, and wiring.
2. Ensure correct placement:
Operator side:
 - Photoeye transmitter (“SMT” or red housing)
 - Light curtain receiver (“SGR”)Adjustor side:
 - Photoeye receiver (“SMR” or yellow housing)
 - Light curtain transmitter (“SGT”)
3. Take the plug-and-play connectors from the control panel and run them to each side of the door. The shorter cable should be routed to the operator side. Secure the wire to the sensor mounting angle using the provided wire clips.
4. Attach the plug-and-play connector to the sensor mounting angle using the provided #12 hardware. Plug in the photoeyes and light curtains.
5. Loosen every other assembly fastener on the guides, starting with the fastener closest to the bottom. Do not fully remove the fasteners.
6. Line up the sensor mounting angle with the loosened fasteners. Lift and push back until the angle rests on the fasteners.
7. Re-tighten the assembly fasteners.
8. Loosen the bottom bar assembly fasteners closest to the guide and insert the provided bottom bar flag as shown in **Figure 9.2**. Re-tighten the fasteners.

⚠ WARNING

The bottom bar flag must be installed prior to commissioning the door. Failure to do so is likely to cause permanent damage to the door.

Figure 9.2 – Sensor Mounting

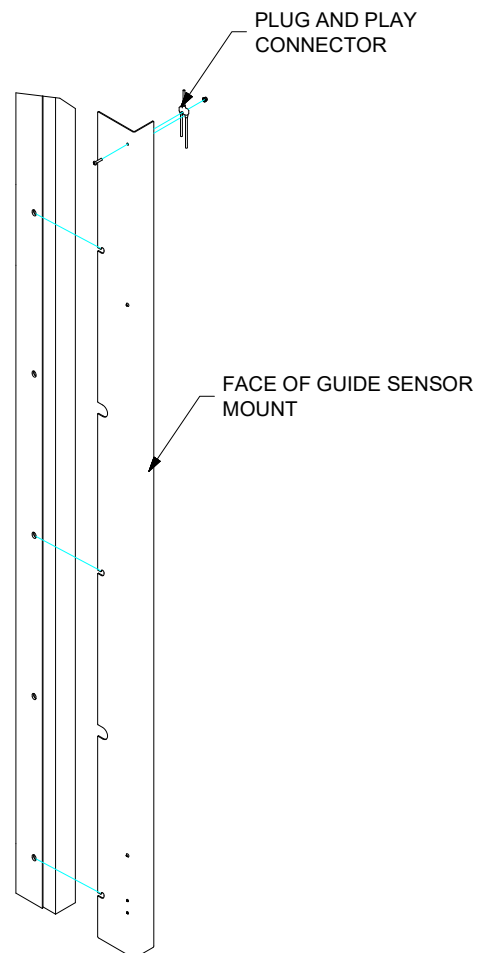
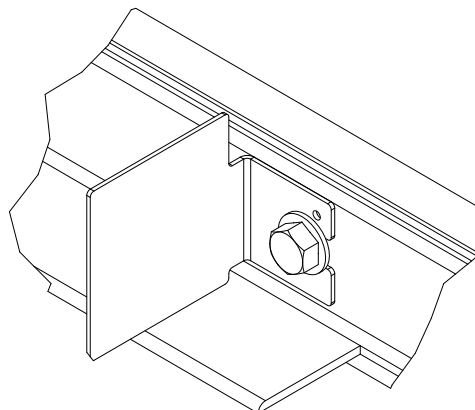

Figure 9.3 – Bottom Bar Flag



SECTION 10 – LINTEL SEAL

▪ “Z” Shaped Seal

Figure 10.1 - “Z” Shaped Lintel Seal Cutout

Note: The Lintel Seal should be installed before the hood and fascia, and after all other door components are installed and operational.

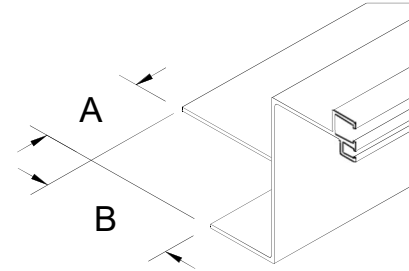

1. Clean and inspect the top of the opening where the *Lintel Seal* will be installed. See shop drawings for details.
2. Make the “A” & “B” cutouts to the ends of the extrusion(s) according to the dimensions on the shop sheet to allow for the guide setbacks and pack-off (see **Figure 10.1**).
3. Mark and drill the mounting holes in the extrusion. Ensure the mounting holes allow sufficient clearance for the fasteners being used to attach the lintel seal. The mounting holes should be spaced at a maximum of 24 inches apart. Position the holes equally between the front edge of the lintel and the back edge of the extrusion.
4. Place the lintel seal at the bottom of the lintel with the brush contacting the curtain (in the closed position) with the bristles pushed to about a 45-degree angle. (See **Figure 10.2**)

Figure 10.2 - “Z” Shaped Lintel Seal

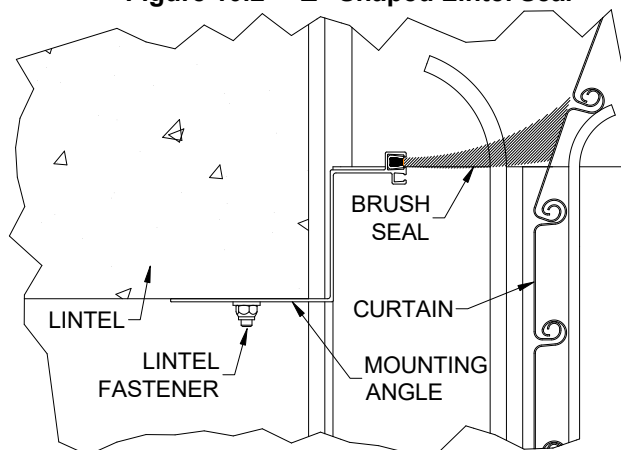

Note: Check the lintel brush for proper contact on the door curtain at the edges and in the middle when the door is both open and closed (mounting extrusion will not sit flush with the corner of the lintel in most cases). On large doors, toward the center, the multi-piece Lintel Seals may have to be angled inward and trimmed on the edges to follow the bow of the door curtain when closed. (Make sure that the brush stays in contact with the door and that the door does not hit the extrusion when it is fully opened.)

5. Once you determine the correct mounting position of the lintel seal, mark the mounting hole locations on the header using the previously-drilled holes in the mounting extrusion as a template.
6. Remove the lintel seal and prepare the mounting hole locations for the proper fasteners supplied with the unit.
7. Replace the lintel seal and insert its fasteners. Before tightening, adjust the seal's alignment to create a straight, gap-free seal against the lintel, ensuring any multi-piece sections are correctly oriented. Once aligned, tighten all fasteners.
8. Operate the door and ensure that the lintel seal sustains sufficient contact with the curtain (the curtain should be in constant contact with the lintel seal but not hit the extrusion).

SECTION 10 – LINTEL SEAL

▪ “L” Shaped Seal

Note: The lintel seal should be installed before the hood and fascia, and after all other door components are installed and operational.

1. Clean and inspect the top of the opening where the *Lintel Seal* will be installed (see shop drawings for details).
2. Mount the angle to the lintel with the correct fasteners according to the wall construction (refer to the job information for the correct location of the angle from the lintel).

Note: Check the lintel brush for proper contact on the door curtain at the edges and in the middle when the door is both open and closed. On large doors, toward the center, multi-piece lintel seals may have to be angled inward and trimmed on the edges to follow the bow of the door curtain when closed (make sure that the brush stays in contact with the door and that the door does not hit the extrusion when it is fully opened)

3. Place the brush extrusion in place on the mounting angle so the brush makes contact with the door in the closed position (brush should be at about a 45-degree angle). Mark the mounting holes locations. Before removing the lintel seal, scribe a line on the back edge of the extrusion and mounting angle. This will help ensure the lintel seal is replaced in the correct location.
4. Remove the lintel seal. Drill the required pilot/clearance holes in the mounting extrusion. The mounting holes should be spaced at a maximum of 24 inches apart. Position the holes equally between the front and the back edges of the extrusion, or as needed to line up with the mounting angle.
5. Replace the lintel seal on the angle using the scribed line as a guide. Mark the mounting holes on the angle using the previously drilled holes in the mounting extrusion as a template. Remove lintel seal and drill the required pilot/clearance holes.
6. Attach the extrusion to the mounting angle with the proper fasteners.
7. Operate the door and ensure that the lintel seal sustains sufficient contact with the curtain (the curtain should be in constant contact with the lintel seal and not hit the extrusion).

Figure 10.3 - “L” Shaped Lintel Seal

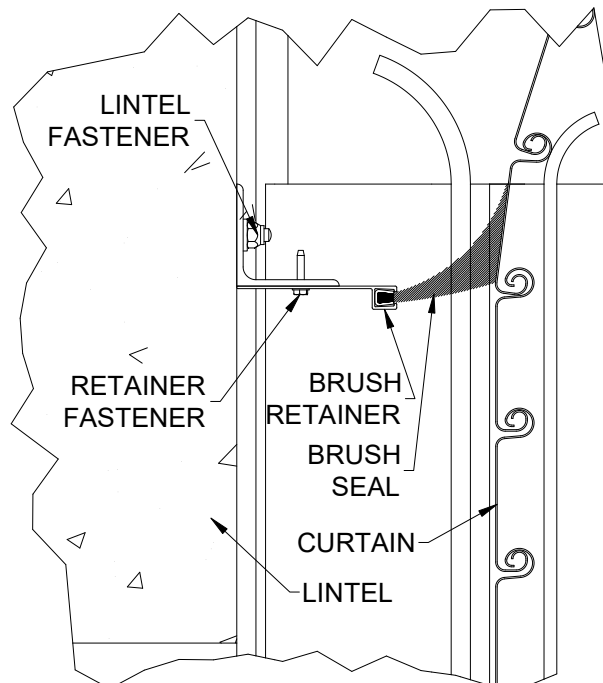

SECTION 11 – HOOD, FASCIA, AND COVERS

▪ **Hood Support installation:**

1. Refer to the job information to determine the type and quantity of hood supports required for your door. Hood supports will be noted on the elevation view of the job construction drawings. See **Figure 11.1** for hood support types.

Figure 11.1 - Hood Supports

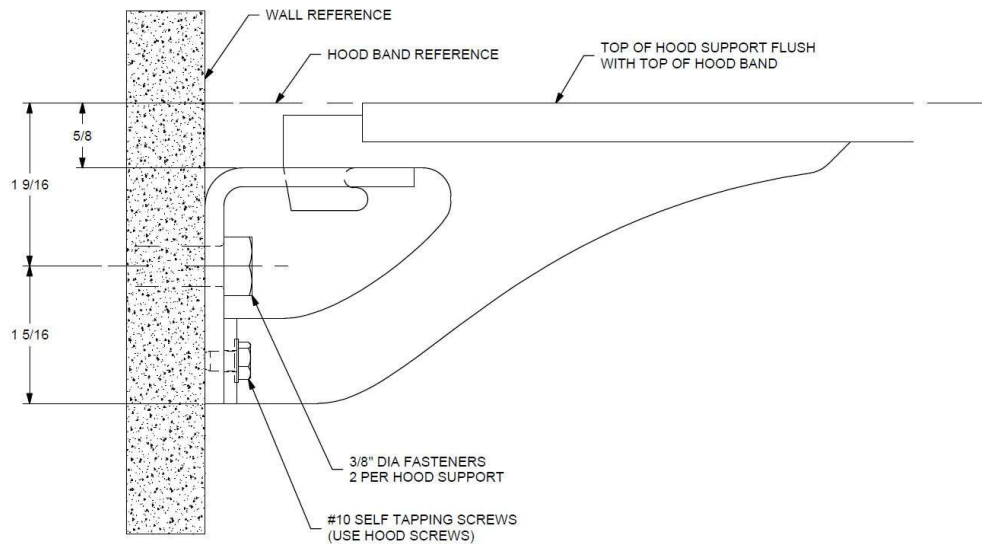

Note: See above detail for face of wall units; the wall angle is offset $5/8$ " from top of hood band to allow hood support to be flush while installing the hood.

SECTION 11 – HOOD, FASCIA, AND COVERS

2. Determine the required number and location of all supports by consulting the job construction drawings.
 - a. If multiple supports are required, see the job construction drawings to determine the centerline of each.
 - b. If a single support is required, it will be located at the center of the unit.
3. Mark a line on the lintel at the centerline of each support.
4. Check the construction at the support locations to be sure it is strong enough to handle the weight of the hood.

Note: *If the construction is not strong enough, do not proceed until rectified.*

5. The term "top of coil" refers to the top edges of the brackets or hood band (see **Figure 11.1.1**).
 - a. If there is a ceiling at the top of the coil, skip the next step.

Figure 11.1.1 – Top of Coil

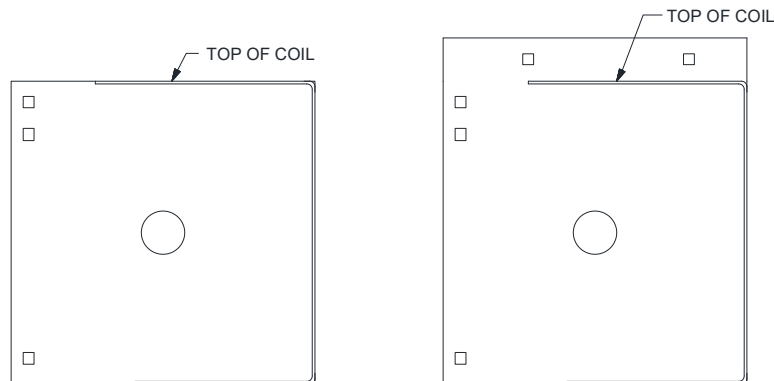

6. Mark a line at the top of the coil at both guides of the unit. Project the lines together to make a continuous line.
 - a. This will help locate the top of the hood support which will keep the hood level.
7. Project a line from the fascia mounting location (fascia mounting channel or fascia side of the tube) from one guide to the other.
8. Mark a line at the support centerline along the fascia line.
9. Prepare the location of the attachment point of the support(s) prior to installing the barrel. This will make installing the support much easier when the time comes to attach it to the lintel/header or ceiling.
 - a. Hold the support in place at the determined location and mark the mounting hole locations.
 - b. Drill holes in the construction and hood support mounting angle.
10. Attach the hood support mounting angle to the lintel/header or ceiling to be sure the mounting holes were located properly.
11. Once the barrel, brackets, curtain are installed, and necessary testing was done on the unit, re-install the hood support.

SECTION 11 – HOOD, FASCIA, AND COVERS

▪ **Hood and Fascia Installation:**

1. Determine what type of hood is provided. See **Figure 11.2** for possible hood configurations. This can be done by:
 - Looking at the brackets and identifying a half-circle shaped flat (D-shaped hood) or straight flats (square or sloped).
 - Looking in the hood box and comparing to the job construction drawings.

Figure 11.2 – Hood Configurations

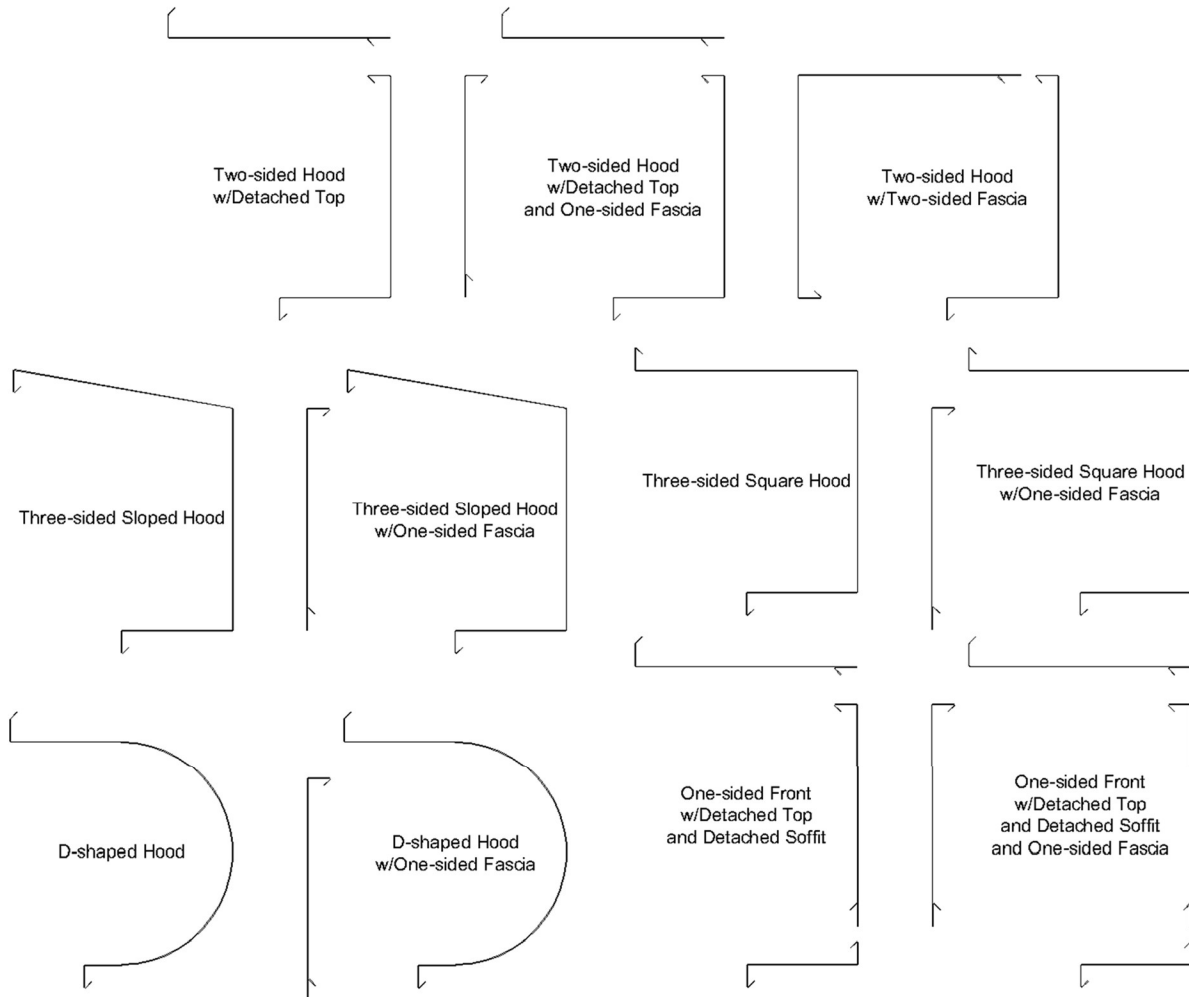

2. If no fascia is included, skip to Step 3.

If a fascia is included, it will be installed first. Fascia fastening varies by job condition but is typically secured to the guides, the brackets, or to the wall. Install the right-most section first, ending in “-R”. Continue leftward adding fascia sections, overlapping the right-hand section by 4”

3. If the hood has more than one section (separate left, right, or center), skip to Step 5.

For single-section hoods, begin with the front-most piece. Install by holding the hood up to the coil area and pushing it against the flats on the brackets. Center the hood so the gap is the same at both

SECTION 11 – HOOD, FASCIA, AND COVERS

brackets. Pre-drill with a #21 or 5/32" drill in at least one place on every face of the hood, at both the left and right sides. See **Figure 11.4** for recommended fastener locations.

4. After fastening the first hood piece, continue with the detached soffit and top, if included.
5. For hoods with multiple sections, begin with the front-most right-hand hood piece, ending in "-R".

Install by holding the hood up to the coil area and pushing it against the flats on the brackets. Butt the hood piece against the bracket to minimize the gap. Pre-drill with a #21 or 5/32" drill in at least one place on every face of the hood, at both the left and right sides. See **Figure 11.4** for recommended fastener locations.

The hood section should cover the hood support completely (approx. 4"). Temporarily clamp hood section to hood support until the next section is installed.

6. Continue leftward installing sections of the same type of hood piece before starting with the right-most soffit or top pieces. See **Figure 11.4** for an example of the order hood pieces should be installed. No cover is used on the splice between hood sections.

Figure 11.3 – Multiple Hood Sections

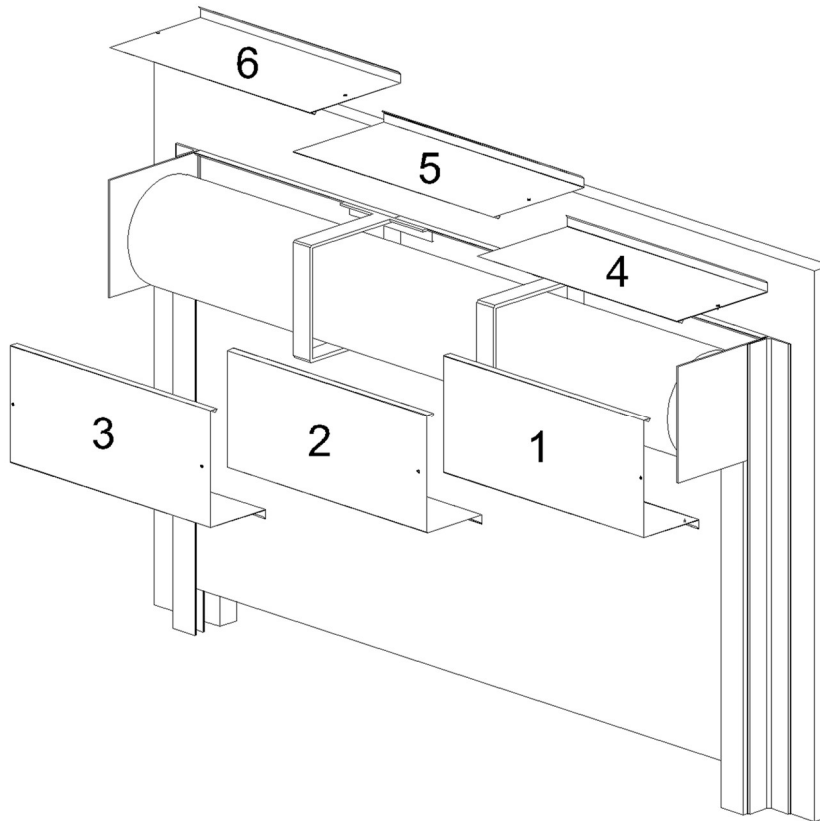

SECTION 11 – HOOD, FASCIA, AND COVERS

Figure 11.4 – Recommended Fastener Locations

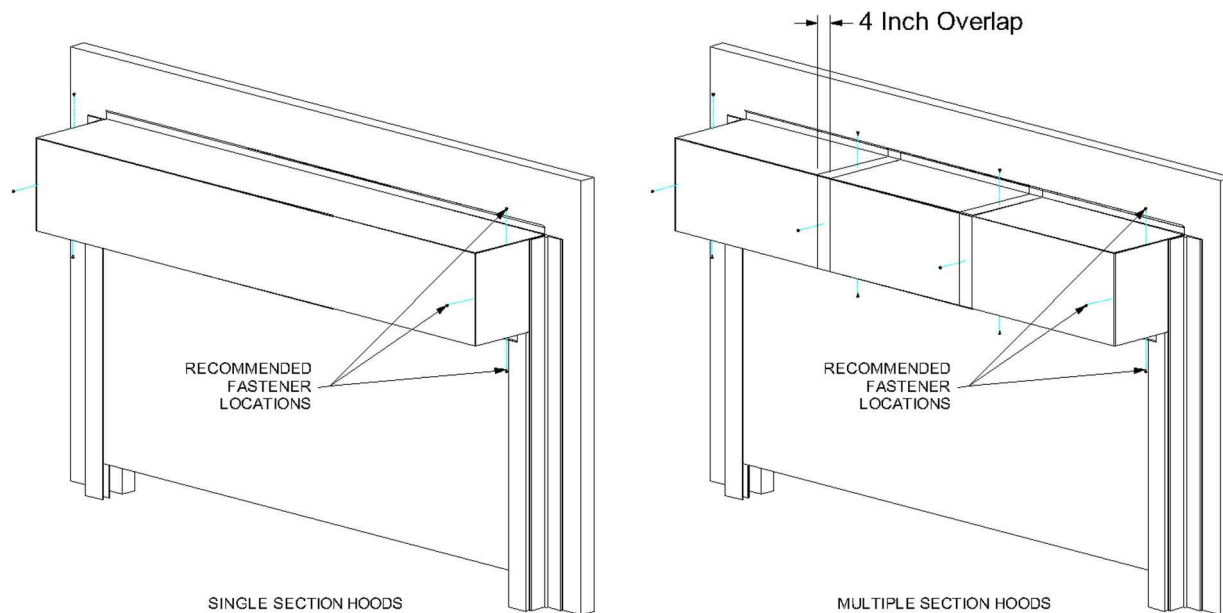

7. If the door is mounted in a weathered or exterior location, caulk the part of the hood that contacts the wall.

▪ **Cover installation:**

1. Once the unit is installed and operating correctly, the covers can be installed.
2. Hood screws may have to be removed and reinstalled to install covers properly.
3. If the cover mounts to the side of the door bracket, pre-drill holes in the bracket to ease installation. A #21 drill size is recommended.
4. If an operator or adjustor cover is provided, individual installation instructions are provided with each cover along with the necessary hardware to attach the cover.
5. Once the cover is installed, operate the door a few more times to be sure there is no interference between the moving components inside the cover and the cover itself.
6. If the door is mounted on the exterior of the building, a bead of silicone sealant should be applied around the entire perimeter of the cover, as it will provide additional protection to the door components.

SECTION 12 – TORQUE SPECIFICATION

Torque Values for Masonry Wall Anchors

Masonry wall anchors shall be installed and torqued per the anchor manufacturer's current published installation requirements.

Torque Values for Assembly Fasteners

Table 12.1 – Torque Recommendations for Guide Assembly and Wall Fasteners

Bolt size/type	Torque (ft lbs) ^a
1/4-20 Grade 2 steel bolt	6
5/16-18 Black Oxide Socket Cap	25
3/8-16 18-8 stainless steel bolt	20
3/8-16 Grade 2 steel bolt	20
3/8-16 Grade 5 steel bolt	31
1/2-13 Grade 5 steel bolt	75
1/2-13 Grade 8 steel bolt	107
5/8-11 Grade 8 steel bolt	212
3/4-10 Grade 8 steel bolt	376

^a The recommended torque for steel bolts is based on a plated bolt that has not been lubricated.

SECTION 13 – MAINTENANCE SCHEDULE



Do not attempt any of the solutions noted unless you have significant experience with door maintenance, its parts, and/or how to handle electrical components.

▪ **Maintenance Schedule:**

Note: If any of the following problems exist, do not operate the door until repaired.

Component	Answer the below as yes or no during the inspection. If no corrective action is required or the corrective action has been completed, proceed to the next step	How often the components must be inspected:			If answer matches below, complete corrective action shown:	Corrective Action:
		Weekly	Monthly	Quarterly		
Curtain & Bottom Bar	Are any curtain components damaged (slats, endlocks, etc.)?	X			Yes	Contact CC Technical Support about replacing damaged parts.
	Is bottom bar damaged?	X			Yes	Contact CC Technical Support about replacing damaged parts.
	Are bottom bar fasteners in place and properly tightened?		X		No	Fasteners must be inspected/replaced and/or properly tightened.
	Are fasteners attaching curtain to the barrel in place and properly tightened?		X		No	Fasteners must be inspected/replaced and properly tightened.
	Do you notice any hang-ups, jamming or other problems preventing the door from moving smoothly throughout the opening?	X			Yes	Check for external issues, if none exist, contact CC Technical Support.
	Do you notice any odd or excessive noise when the door is operated?	X			Yes	Check for external issues, if none exist, contact CC Technical Support.
	If there is a bottom seal, is it damaged?		X		Yes	Contact CC Technical Support about replacing damaged parts.
	If there is locking, does it function properly?	X			No	Check for external issues, if none exist, contact CC Technical Support.
Brackets	Are brackets plumb and perpendicular with wall?			X	No	Contact CC Technical Support.
	Are bracket fasteners in place and properly tightened?			X	No	Fasteners must be inspected/replaced and properly tightened.
	Do you notice signs of excessive wear on the bearings (i.e. binding, excessive noise, etc.)?		X		Yes	If there is a grease fitting, apply grease, if not, contact CC Technical Support.
	Is adjusting wheel & pin secure?			X	No	Contact CC Technical Support.
	Is drive chain sufficiently lubricated?			X	No	Apply chain lube.
	Is drive chain in need of tightening?			X	Yes	Contact CC Technical Support for instructions on how to tension the chain.
	Is drive or driven sprocket damaged?		X		Yes	Contact CC Technical Support about replacing damaged parts.
Guides	Are wall fasteners in place and properly tightened?		X		No	Fasteners must be inspected/replaced and properly tightened.
	Are guide assembly fasteners in place and properly tightened?		X		No	Fasteners must be inspected/replaced and properly tightened.
	Is guide gap dimension correct?		X		See Corrective Action	Check job construction drawings and adjust gap as required. If job construction drawings are not available, contact CC Technical Support.
	Are any of the guide parts bent or damaged?		X		Yes	Contact CC Technical Support.

SECTION 13 – MAINTENANCE SCHEDULE

	Are stoppers loose, damaged, or missing?		X		Yes	Stoppers must be inspected/replaced and properly tightened.
Hood and Fascia	Is hood/fascia dented or damaged?			X	Yes	Remove hood/fascia. Repair if possible. If not leave hood/fascia off and contact CC Technical Support.
	Is curtain rubbing against the hood/fascia?	X			Yes	Hood/fascia may have been damaged. Contact CC Technical Support.
	Is hood/fascia level?			X	No	Check fasteners, they may be loose or missing. Replace as soon as possible.
	Are guide assembly fasteners in place and properly tightened?		X		No	Fasteners must be inspected/replaced and properly tightened.
	Is hood support level?			X	No	Check fasteners, they may be loose or missing. Replace as soon as possible.
Door Operation	Does the door require excessive force to open?		X		Yes	Check for hang-ups or obstructions. Ensure spring tension is set correctly. Contact CC Technical Support.
	If the door contains locking, does the locking mechanism function properly and securely hold the door in the closed position?		X		No	Check for damage and other external issues. Contact CC Technical Support.
	If there is a sensing edge, does it function properly?	X			No	Cut power and check for loose wires. Contact CC Technical Support for further instruction.
Motor Operator	Are the fasteners attaching the motor-to-the mounting bracket, and mounting bracket-to- the door bracket secure?			X	No	Fasteners must be inspected/replaced and properly tightened. Contact CC Technical Support for replacement hardware.
	Are the sprockets properly aligned?			X	No	Realign the sprockets as secure using the set screws. Recheck chain tension.
	Are the sprocket keys properly aligned with sprockets and securely fastened with the set screws?			X	No	Reposition the keys so they fully engage the keyway in the sprocket. Tighten the set screws.
	Is the door stopping correctly at the open (before bottom bar contacts the stoppers) and closed (as soon as the bottom bar contacts the floor) positions?		X		No	Limits may have to be adjusted in the motor operator. Refer to the operator owner's manual or contact CC Technical Support.
	Is the operator functioning normally?		X		No	Refer to the <i>Operator Troubleshooting Table</i> on the following page to diagnose the problem.
Inertia Brake	Is the red tab pushed out of the housing?	X			Yes	Contact CC Technical Support
	Is the safety brake making any unusual noise or vibrating while the door is operating?	X			Yes	Contact CC Technical Support

SECTION 13 – MAINTENANCE SCHEDULE

▪ **Operator Troubleshooting:**

Note: If you suspect you are having an issue with your operator, use the following table to determine the potential causes. If the provided solution does not eliminate the issue, or the table does not address your particular problem, contact CornellCookson Technical Support.

Component	Problem	Potential Cause	Solution
Motor Operator	Motor Operator does not run when OPEN or CLOSE button is pushed	The circuit breaker may be flipped or fuse blown.	Reset breaker or replace fuse. Contact CC Technical Support if replacement fuse is needed.
		The thermal overload may be tripped.	Reset thermal overload.
		Manual interlock switch is open (on units with emergency operator).	Close manual interlocks.
		External interlock may be opened.	Close external interlock.
	Motor operator runs, but the door does not move	Sprocket key may be missing or drive chain may be broken.	Contact CC Technical Support for repair parts. Install key or replace chain.
		Clutch may be slipping.	Adjust if possible. Otherwise, contact CC Technical Support.
	Motor hums, but does not run	Door or drive chain may be jamming.	Check for hang-ups or obstructions. Try to operate manually. If issue persists, contact CC Technical Support.
		Dead phase in 3 phase system.	Check power supply.
		Brake does not release.	Check power to brake solenoid.
		Open motor winding.	Check that all connections are secure.
	Motor operator runs in wrong direction and limits do not function	3 phase operator power supply is out of phase.	Interchange any 2 power leads to unit.
	Door drifts when motor shuts off	Brake may be improperly adjusted or broken.	Check brake components. Contact CC Technical Support for replacement parts or adjustment instructions.
	Motor operator does not shut off at full OPEN or at full CLOSE position	Limits may need adjustment.	Refer to the operator owner's manual to readjust limits.
		Sprocket on limit shaft may be slipping or limit drive chain may be broken.	Ensure sprocket key is correctly installed and set screws are tightened. Contact CC Technical Support for replacement chain, if broken.
		Limit switch may be defective.	Contact CC Technical Support.
Limit Switches	Limit switch does not hold setting	Drive chain may be too loose, allowing the chain to jump sprocket teeth.	Adjust chain to proper tension. Contact CC Technical Support for additional information.
		Limit nut retainer not engaging slots in limit nuts.	Be sure retainer is securely engaged in slots of both limit nuts.
		Limit nuts binding on screw threads, allowing them to jump position on retainer.	Lube screw thread. Check that limit nuts turn freely.

SECTION 13 – MAINTENANCE SCHEDULE

Maintenance Schedule						
Cycles/Time (Whichever Occurs First)						
	75,000/ 6 Months	150,000/ 12 Months	225,000/ 18 Months	300,000/ 24 Months	375,000/ 30 Months	450,000/ 36 Months
Visual Inspection	Inspect	Inspect	Inspect	Inspect	Inspect	Inspect
Bracket Bearings	Inspect	Lubricate	Inspect	Lubricate	Inspect	Inspect
Drive Chain (if required)	Inspect	Lubricate	Inspect	Lubricate	Inspect	Inspect
Limit Nuts/Shaft (If required)	Inspect	Lubricate	Inspect	Lubricate	Inspect	Inspect
Motor Operator	Inspect	Inspect	Inspect	Inspect	Inspect	Inspect
Operator Brake Operation	Test	Test	Test	Test	Test	Test
Inertia Brake (if required)	Inspect	Inspect	Inspect	Inspect	Inspect	Inspect
Sensing Edge (if equipped)	Test	Test	Test	Test	Test	Test
Photo Eyes/Light Curtain	Test	Test	Test	Test	Test	Test
Bell Mouths	Inspect	Inspect	Inspect	Inspect	Inspect	Inspect
Guide Wear Strip	Inspect	Inspect	Inspect	Inspect	Inspect	Inspect
Maintenance Date						
Cycle Counter Readout						
Servicer Initials						

SECTION 13 – MAINTENANCE SCHEDULE

Comprehensive Maintenance

<u>Item</u>	<u>Check</u>
Visual Inspection	Visually inspect door for unreported damage. Repair or replace any damaged parts. Visual inspection includes curtain, guides, hoods, and control panel.
Operational Check	Operate door one full cycle while inspecting door operation for binding, straining, or unusual noises. Correct any operational problems found.
Motor Check	Operate door one full cycle while checking motor for unusual noises, smells, or smoke. Correct any motor operational problems found.
Drive Chain Lubrication/Inspection	Inspect roller chains, sprockets, and gears. Replace any sprockets or gears with teeth worn where they do not operate smoothly. Lubricate chains and gears with SAE approved gear oil. Adjust chain tension as required. Replace chain if stretched to point where it makes noise.
Safety Brake Inspection	Verify that red tab is not pushed out of housing. Operate door one full cycle while checking for unusual noises and vibration. If red tab is pushed out or if unusual noises or vibrations are witnessed, Contact Service.
Limit Shaft/Nuts	Verify the threads on the limit shaft are not worn and are lubricated properly. Check for excessive shaft end play. Verify the limit nuts do not wobble excessively or bind on the limit shaft. Use SAE approved gear oil for lubrication.
Operator Inspection	Operate door in the close direction and hit the “Stop” button when the bottom bar is about 36” above the finished floor. Verify that the brake does not allow the door to continue to move in the closed direction more than 2” after the initial brake engagement.
Bracket Bearings	Inspect the bracket bearings for worn outer races and debris. Lubricate the bearings with bearing grease via the supplied grease fittings.
Sensing Edge	Operate the door in the closing direction and contact the edge to verify edge functions and door returns to the fully open position. Check the battery condition in the transmitter and replace battery if required. Inspect the bottom surfaces of the edge for cracking or separation at ends.
Photo-Eyes/Light Curtains	Operate the door in the closing direction and place an obstruction in the path of the photo-eyes as the door is in mid-travel. Verify that the door stops and reverses to the fully open position.

APPENDIX A – VINYL GUIDE WEATHER SEAL

▪ Guide Weather Seal Installation Instructions

⚠ CAUTION

To install the seal properly, use a rubber mallet. Do not use a steel hammer.

The seal material can crack in freezing temperatures. If possible, store the seal in a location above freezing until you are ready to install it.

Figure A.1 – Guide Weather Seal

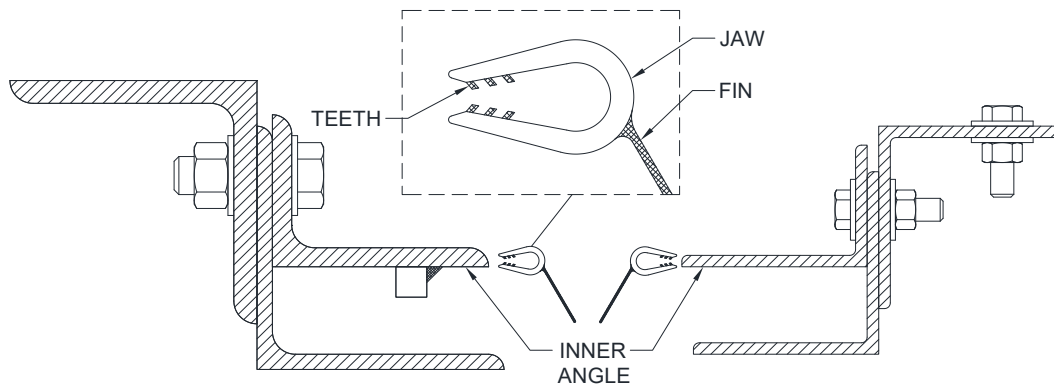

1. The seal should cover from the bottom of the bracket to the bottom of the guide. Check this by measuring the seal or holding it directly against the guide. If the seal does not cover from the ground to the bottom of the bracket, a spliced section is needed, and you should proceed to step 2. If no splice is required, proceed to step 3.

2. If a splice is required, a Craftsman Handi-Cut™ specialized utility cutter is recommended. Alternatively, a pair of tin snips or other specialized cutting device for flexible materials can be used to cut the seal. Trim the bottom of the upper piece at a 45-degree angle from the jaw through to the fin (see figure A.1 for the “jaw” and “fin” structure of the seal). Trim the top of the lower piece at a 45-degree angle from the fin and jaw. See adjacent figure B.2 for how to trim the seal. Tape or other adhesive can be used to join the spliced weather seal, if desired.

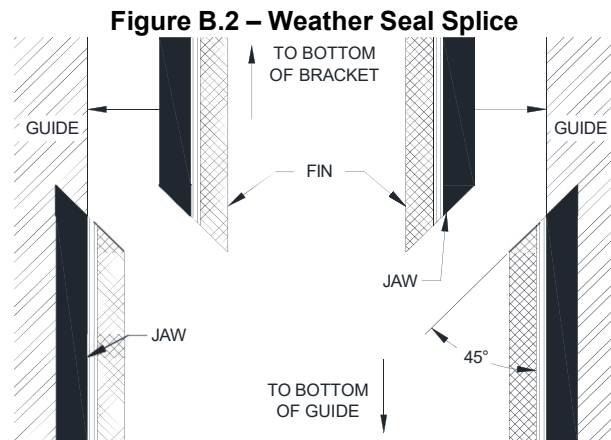

3. Start at the top of the guide and work downward. Be sure that the seal is fully seated on the angle.

****NOTE - Starting at the bottom may be difficult, as the flexibility of the material will cause it to pull away from the guide as it is being installed.**

4. Run the door up and down a few times to ensure that the seal is installed properly.