

ROLLING FIRE DOORS AND COUNTER FIRE SHUTTERS

ALARMGARD® TUBE MOTOR OPERATOR

AlarmGard® Tube Motor Operators are concealed in the shaft assembly, making them ideal for openings with tight clearances or when you need to conceal the operator drive components without adding a bulky and unsightly motor cover. The AlarmGard Tube motor operator can be used on Fire Doors or Counter Fire Shutters.

Features and Benefits

- Convenience of motor operation in a low profile, concealed design.
- Auto-Reset and selectable Auto-Open.
- Available with or without battery back up.
- UL 325 compliant and UL 864 Listed motor assembly.
- Rated for up to 10 cycles per day.
- Electrical Connections from the operator to wall mounted control panel is plug and play.
- Internal fail-safe release device and internal centrifugal governor.



Product Application Requirements

- An AlarmGard tube motor can operate a fire door or a fire counter shutter up to approximately 120 ft².*
- Requires 115 VAC/50 Hz or 230 VAC/60 Hz** Power and 24 Volt alarm input.

*Size limit varies by door configuration and gauge required.

**Special order - additional lead time applies.



Technical Specifications

Input Voltage	115 VAC/60 Hz 230 VAC/50 Hz**
Activation Input	4 V
Phase	1
Duty	up to 10 cycles/day
Auxiliary Manual Operation	No

Technical Drawings

The AlarmGard Tube Motor will eliminate the need for an additional 16" on front of coil in comparison to the Standard AlarmGard Motor Operator.

AlarmGard® Tube Motor

Front View

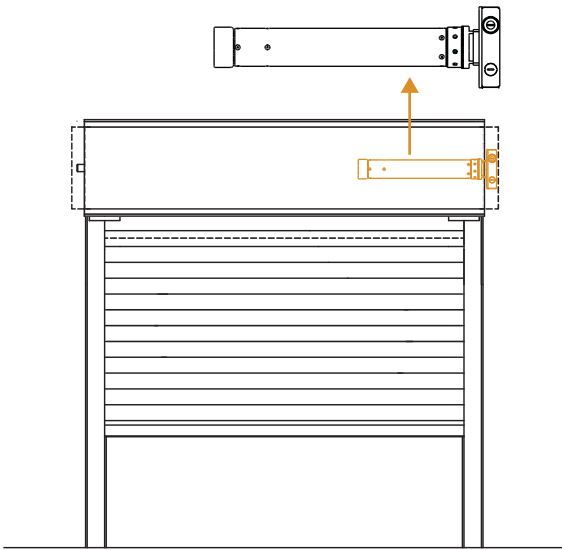

AlarmGard® Tube Motor

Side View

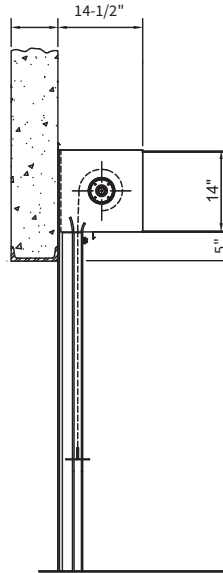

Standard AlarmGard® Motor Operator

Side View

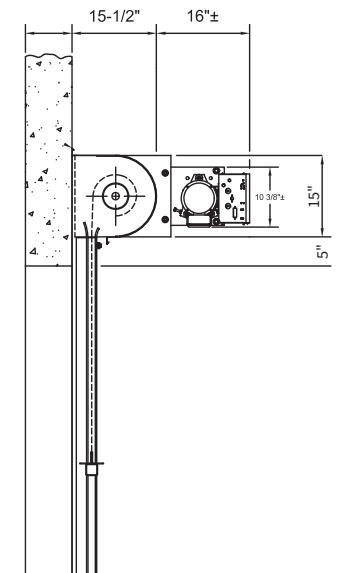

Motor Control Panel

Battery Back Up Motor Control Panel

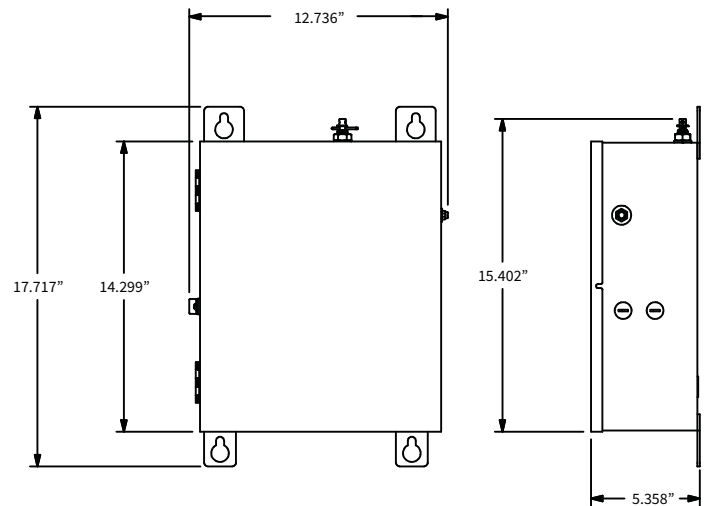
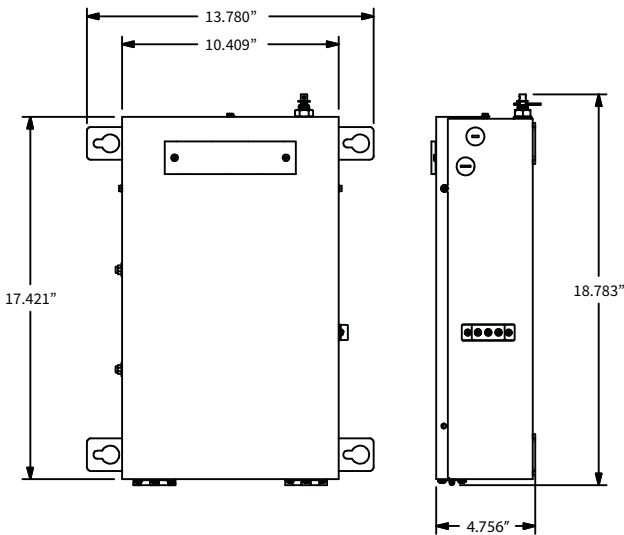

CUSTOM-DESIGNED SOLUTIONS

Our experienced Architectural Design Support Team can customize our products to fit your specific application.

Call 800.233.8366 ext. 4551 • ads@cornelliron.com