

# CORNELL

## Rolling Service Doors

### Model ESD10

#### Practical Design Applications

- Industry
- Distribution
- Healthcare
- Transportation
- Retail
- Utilities
- Education
- Hospitality/Public Space

#### Benefits

- Q/S Program - Cornell can manufacture and ship most standard service doors in one to two weeks.
- Powder coated guides, bottom bar and bracket plates are standard.
- Size Flexibility - each unit is built to exact opening size requirements.
- Compact Storage - curtain stores in an overhead coil that is totally supported by the side guides.
- Low Life Cycle Cost - rugged construction and commercial quality materials assure long life.
- Maintenance - little to none.
- Repairs - job records are retained and parts are readily available.

#### Available Options

- Vision windows
- Perimeter weather-stripping
- Cylinder or slide bolt locking
- Bottom bar sensing edge for motorized units
- Windloads exceeding 20 psf
- Operator covers for exterior mounted units or exposed operators below 8'-0" high



## Specialty Service Doors



#### Matadoor®

A highly visible safety orange colored breakaway curtain bottom section that controls damage and opening downtime.



#### ScreenGuard™ Door

Achieve visibility and ventilation while maintaining security and insect control. Perforated 20 gauge steel slats provide approximately 22% open space.



#### Graphics Door

Durable, full color images applied to door curtains and hoods. Create sponsorship opportunities, educate, inform or add aesthetic interest.



#### QS24 Service Door Model ESD11

Economical, commercial duty doors available in sizes ranging from 5' x 5' to 12'W x 20'H.

# Service Door Components

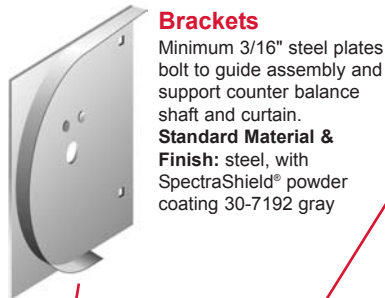

## Brackets

Minimum 3/16" steel plates bolt to guide assembly and support counter balance shaft and curtain.

**Standard Material & Finish:** steel, with SpectraShield® powder coating 30-7192 gray



## Counter-balance Shaft

4-1/2" minimum diameter outer shaft and 1-1/4" minimum inner shaft. This assembly supports the curtain and contains counter-balance torsion springs for assisting operation.

**Standard Material:** steel



## Hood

Protective sheet metal enclosure for the curtain that provides weather resistance at the head of the door and keeps the brackets rigid.

**Standard Material and Finish:** Galvanized steel with exclusive GalvaNex™ finish in light gray

**Optional Materials:** aluminum, stainless

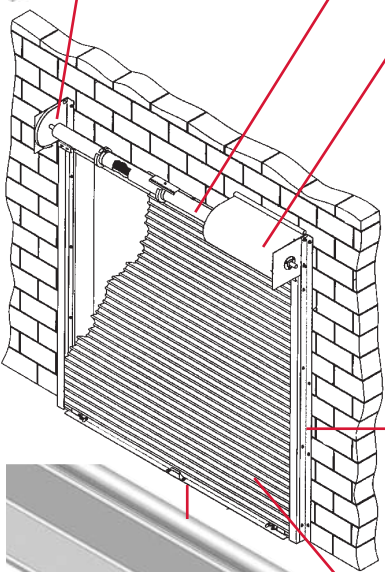

## Guides

Minimum 3/16" angle assemblies bolt to the wall and support the entire weight of the door.

**Standard Material & Finish:** steel with SpectraShield® powder coating 30-7192 gray

**Optional Materials:** extruded aluminum, stainless or aluminum angles

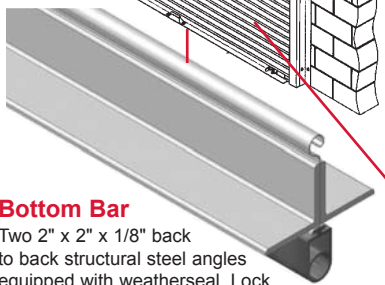

## Bottom Bar

Two 2" x 2" x 1/8" back to back structural steel angles equipped with weatherseal. Lock mechanisms available.

**Standard Material & Finish:** steel with SpectraShield® powder coating 30-7192 gray

**Optional Materials:** extruded aluminum, stainless or aluminum angles



## Curtain

Interlocking roll formed slats with endlocks riveted to ends of alternate slats to maintain slat alignment and prevent wear. Built to withstand a 20 psf windload.

**Standard Material & Finish:** Galvanized steel with exclusive GalvaNex™ finish in light gray

**Optional Materials:** aluminum, stainless

## Operation

Push-up operation shown. Hand chain, hand crank and motors are available. Doors operate by rotating the shaft gear end. The opposite end of the shaft applies spring tension and is equipped with a spring adjusting wheel.

## Mounting & Clearances

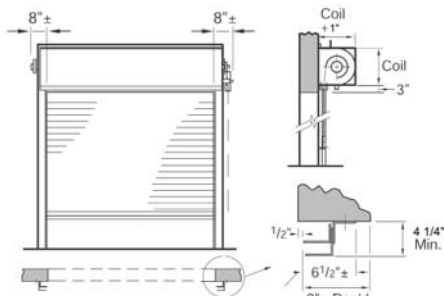

### Face of Wall

Maintains clearance of full opening, minimal exposed components.

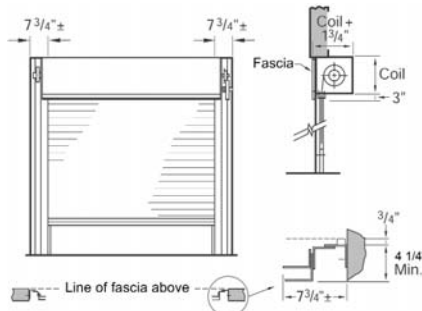

### Between Jambs

Mounts within the opening, fascia (front hood closure piece) required.

Standard service doors are built to order to fit specific dimensions up to 40' wide, 30' high.

Additional designs for large openings in excess of 40' wide by 30' high. Consult factory for doors over 500 sq. ft.

## Special Applications

- High Cycle Construction - for doors expected to operate more than 20 cycles per day such as parking garage doors, Sally ports and certain industrial applications.
- Fast Acting Doors - doors designed to operate at a speed of 2 ft./second. This is more than twice the speed of typical rolling doors.
- Horizontal Closures - close off floor openings or cover tanks or machines.
- Combination Doors - combines two different curtains on the same opening. Typically an insulated door is used in conjunction with either a ScreenGard™ door or an open design rolling grille.
- Craneway Doors - have curtains designed in the shape of a "T" to accommodate overhead crane rails passing through an opening.
- Sloping or Irregular Sills - special bottom bar designs meet odd floor conditions including slopes, curbs or rails.
- Pass Doors - a hollow metal man door and hinged frame within a rolling door curtain.
- Removable Guide Mullions - used for extra wide openings that require full access on a limited basis.

## Optional Finishes

- Galvanized steel with exclusive GalvaNex™ finish in tan or white
- Aluminum in mill, clear or color anodized
- Stainless steel, 300 series #4 finish
- Hot-dip galvanizing on steel components
- Powder coat finish in selected color
- Zinc Rich Gray corrosion resistant powder coating

## SpectraShield® Powder Coat Finish

Cornell's SpectraShield® Powder Coat Finish adds durability and aesthetic value to our products in a choice of over 200 colors. Surface preparation and the coating process produces a smooth, long lasting finish at controlled costs.

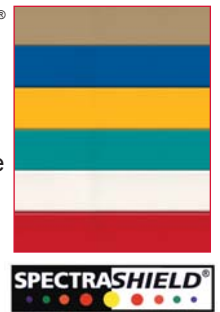

**CORNELL**  
SAFE AND SECURE

An ISO 9001:2000 Registered Company

Crestwood Industrial Park  
Mountaintop, PA 18707  
TEL 800.233.8366 • FAX 800.526.0841  
Engineering Design Services: Ext. 551  
Website: [www.cornelliron.com](http://www.cornelliron.com)  
Email: [cornell@cornelliron.com](mailto:cornell@cornelliron.com)