

Firemiser™ Insulated Fire Door

Model ERD20

One Door - Many Benefits

Now you can provide UL rated fire protection *plus* security, sound attenuation, environmental separation and smoke control all with the Firemiser insulated fire door from Cornell. Reduce costs by specifying a single Firemiser door to meet multiple design needs, then continue to cash in on the energy savings generated by Firemiser's sealing and insulation.

Achieve **Rolling Steel Security** with up to **4 hours of UL Labeled Fire Protection**, plus:

- **Sound Attenuation** - A Sound Transmission Class rating of STC 27 makes Firemiser's mineral wool insulated curtain an excellent choice to maintain fire wall integrity and reduce decibel levels. Use Firemiser in schools, production facilities, hospitals, office buildings or anywhere that the combination of fire protection and sound attenuation is desired.
- **Climate Control** - Firemiser's insulated curtain yields a 5.3 R-value that can be combined with full perimeter seals for use at exterior or interior openings whenever fire protection and environmental separation is required.
- **Smoke Control** - Firemiser is also available with a UL label for smoke and draft control. Specify Firemiser with SmokeShield® construction and gain labeled protection against the passage of smoke and gases through the opening

Practical Design Applications

- All fire wall openings where the door is to be closed regularly and a sound attenuation need exists.
- Exterior openings that require a fire rating due to the proximity of other structures or combustible materials.
- Buildings designed for future expansion where current exterior wall openings are to become interior fire wall openings.
- Interior fire wall openings where the door will be normally closed to control varying climatic conditions between two areas.



Other Available Features and Benefits

- M100 Chain or available M100 Motor and M100 Crank automatic closing systems provide safe and convenient operation. Spring tension resetting is never required and automatic closing speed is safely controlled not to exceed 9" per second.
- UL Labels available for 4, 3, 1 1/2, 1 or 3/4 hour performance. Factory Mutual Approval
- Flame spread and smoke development index factors for Firemiser's mineral wool insulation are zero as tested per ASTM E84.
- With each unit built to exact opening size requirements, you have size flexibility up to 34' wide and 22' high. Consult factory for units over 270 square feet.
- All Firemiser units are supplied to withstand a 20 psf test wind load.
- Full range of finish, mounting and locking options.
- Cornell's exclusive 2-Year Quality Warranty, standard.

CORNELL
SAFE AND SECURE

Firemiser™ Door Components



Brackets
Minimum 1/4" steel plates that bolt to the guide assemblies and support the counter-balance shaft and curtain.
Standard Material & Finish: steel with SpectraShield® powder coating 30-7192 gray

Counter-balance Shaft
4 1/2" minimum diameter outer shaft and 1 1/4" minimum inner shaft. This assembly supports the curtain and contains counter-balance torsion springs for assisting operation.
Standard Material: steel

Hood
Protective sheet metal curtain enclosure that provides fire resistance at the head of the door.
Standard Material and Finish: Galvanized steel with exclusive GalvaNex™ finish in light gray
Optional Materials: stainless steel

Guides
Minimum 1/4" angle assemblies fasten to the wall and support the entire weight of the door.
Standard Material & Finish: steel with SpectraShield® powder coating 30-7192 gray

Curtain
Double skin interlocking roll formed slats filled with 7/8" thick mineral wool insulation. Combination cast iron endlock/windlocks are riveted to ends of alternate slats to maintain slat alignment, lock curtain into guides and prevent curtain wear. Supplied to withstand a 20 psf test windload. R-value is 5.3 as calculated using the ASHRAE Handbook of Fundamentals. STC 27 rating.
Exterior/Interior slat skins available in: 24/24 or 22/22 gauge galvanized steel, gray enamel or 22/22 stainless steel, #4 finish.
Standard Material & Finish: Galvanized steel with exclusive GalvaNex™ finish in light gray
Optional Materials: stainless steel

Bottom Bar
Two 2" x 2" x minimum 1/8" back to back structural steel angles. Lock mechanisms available.
Standard Material & Finish: steel with SpectraShield® powder coating 30-7192 gray
Optional Materials: stainless steel

Operation
M100 Chain operator standard. M100 Motor or M100 Crank operators are available. Fire Doors operate by rotating the shaft gear end. The opposite end of the shaft applies spring tension and is equipped with a spring adjusting wheel.

Mounting & Clearances

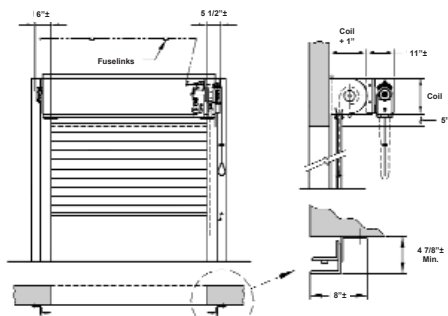

Face of Wall

Maintains clearance of full opening, minimal exposed components.

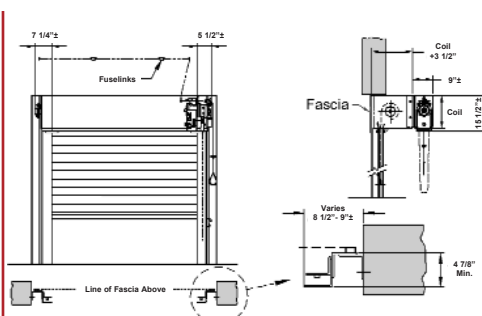

Between Jambs

Mounts within the opening, fascia (front hood closure piece) required.

Standard construction Firemiser Fire Doors are built to order to fit specific opening dimensions to 34' wide and 22' high. Consult factory for units over 270 sq. ft.

Fire/Smoke Control Options

■ Perimeter Seals - UL listed brush seals applied to guides, bottom bar and door header provide weather resistance and/or protection against the passage of smoke and gases around Firemiser.

■ Release Devices - Fail-safe electro-mechanical devices for M100 Chain and Crank units that initiate automatic closing in response to an alarm signal or following a ten second power outage. Battery back-up versions last up to 72 hours without initiating a release due to a power failure.

■ Annunciators - safety devices that provide a visual and/or audible advanced warning when the Firemiser is about to close. Can be activated upon alarm signal or loss of power when supported by a battery back-up device.

■ Smoke Detectors - when not part of a central alarm system, photoelectric or ionization detectors are available for local activation of fire door release systems.

Optional Finishes

- Curtain and hood with GalvaNex™ coating system in tan or white
- Stainless steel, 300 series #4 finish, for curtain, bottom bar and hood.
- Hot-dip galvanize on steel components
- Zinc Rich Gray corrosion resistant powder coating
- SpectraShield® Powder coat finish in selected color

SpectraShield® Powder Coat Finish

Cornell's SpectraShield® Powder Coat Finish in a choice of over 200 colors adds durability and aesthetic value. Surface preparation and coating process produces a smooth, lasting finish.



CORNELL

SAFE AND SECURE

An ISO 9001:2000 Registered Company

Crestwood Industrial Park
Mountaintop, PA 18707

TEL 800.233.8366 • FAX 800.526.0841

Engineering Design Services: Ext. 551

Website: www.cornelliron.com

Email: cornell@cornelliron.com