

# CORNELL

# TRANZFORM<sup>®</sup>



## TRANZFORM FIRE

MODEL ERP10

UL Classified Fire and Smoke Protection  
with Emergency Egress Capabilities

Designed to provide automatic closing in the event of fire detection, TranZform Fire units are rated physical fire barriers that protect openings from the spread of fire and smoke. TranZform Fire units can be used in openings that are part of a required means of egress. Its minimal headroom track and double wall panel design features fire retardant, flexible header and floor seals attached to the top and bottom of the panels to protect against the passage of fire, air and smoke. No floor track required. Up to 3 hour UL Classified fire rating, UL "S" label smoke rating and FM ratings are available. With Emergency Egress Hardware provided as standard, TranZform Fire units are compliant with the Americans with Disabilities Act accessibility standards. STC 41. IBC<sup>®</sup> compliant per ICC-ES ESR 2300.



## TRANZFORM SOUND

MODEL ESP20

STC 45: Unparalleled Sound Control

In addition to providing privacy and security separation, Cornell's TranZform Sound units offer unparalleled sound control. Its double wall panel design allows both interior walls to be completely covered with continuous blankets of sound absorbing material. TranZform Sound achieved an STC 45 when tested to today's ASTM E90 standards by an independent laboratory. When Noise Isolation Class (NIC) field tested in the same opening as a competitor's product that claims the best sound control in the industry with a higher listed STC rating, Cornell's TranZform Sound product emerged as the acoustic control champion.



## TRANZFORM SPACE

MODEL ESP10

Convenient Space Separation, Security

Though similar in finished appearance, TranZform Space units feature single wall panel construction with a bonded vinyl finish on public side standard, vinyl both sides optional in a finish as selected by the end user. Use in areas where convenient separation of space is desired, but fire control or higher level acoustic control is not a concern, such as off hour pedestrian control, closets and storage areas. STC 30.

SIDE FOLDING ACCORDION PRODUCTS

## Ratings / Listings

- UL Classified 3, 1 1/2, 1, 3/4, 1/2, 1/3 hour and "S" labels available.
- Factory Mutual Approvals Listing. ■ STC 41
- Compliance with the American with Disabilities Act accessibility standards. ■ CSFM Listing
- Acceptable for use in openings that are part of a required means of egress. ■ ICC-ES ESR-2300

## Operation

**Fail-safe emergency response capability.** When an alarm is activated, TranZform Fire closes automatically to prevent the spread of fire and smoke. In emergency mode, pressure on the vertical exit bar causes door to open at least 54", pause for 3 seconds, then automatically close. Closing fire doors can also be opened manually by pushing against the leading sensing edge.

## Key Product Components/Construction

**TranZform Fire Hang Weight** - approximately 5.5 lbs. per square foot, extended.

**Size** - Openings from 3' 6" to 22' H to a max. of 1440 sq. ft, standard construction.

### Practical Applications -

- Openings requiring building code compliant emergency egress
  - elevator lobbies
  - horizontal exits
  - opening protectives in fire rated corridors
- An alternative to banks of fire rated swing doors where maintaining the use of the full opening width for functionality and aesthetics is desired.
  - atriums ■ casinos
  - hotels and conference centers
- Openings with minimal headroom requiring rated fire, smoke or ADA compliant fire protection
- Stage Proscenium Openings

**Lead Post** - 24 gauge commercial grade coated steel member with material and finish to match panels. Lead sensing edge and full length interior tubing support provided standard. An internally mounted stabilizer bar support shall keep the lead posts vertical and in proper alignment during operation and ensure tight fitting closure of the door.

**Wall Mounted Strike Post** - Recessed 18 gauge coated cold rolled steel member that receives the lead post and is secured to the wall opposite the stacked door. Finish to match panels.

### Product Options

- Single Slide or Bi-Parting construction
- Curved track ■ Non-sway construction
- Vision Panel ■ Pocket Doors
- Powder coat finish colors: consult factory

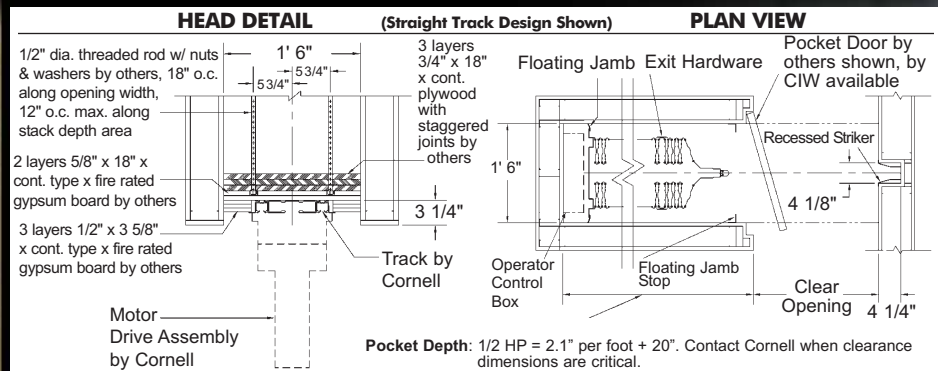
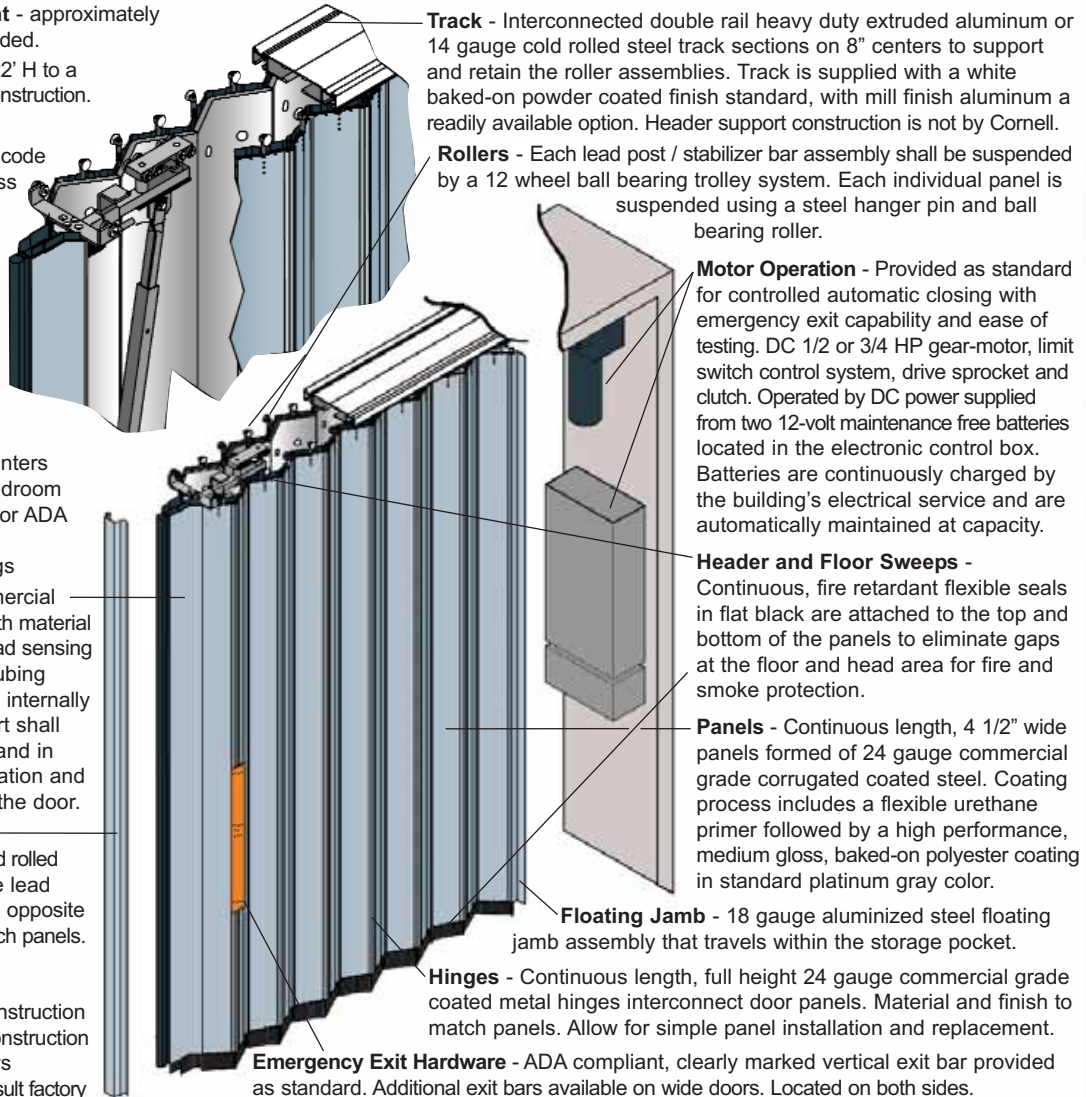

# TRANZFORM<sup>®</sup> SPACE & SOUND

Cornell side folding accordion partitions can accommodate virtually any width opening. With the track capable of being recessed into the ceiling construction and with use of a recessed pocket, they store virtually out of sight and mind allowing full use of building space. Then, as needed, all TranZform units can be easily moved into place allowing for convenient and private space separation. Cornell accordion partitions are solely supported by a low headroom overhead track and are built to opening height requirements from 3'6" to 22' Sound units and 3'6" to 14' for Space Units.

**Stock Finishes:** Printed representation only. Contact Cornell for color accurate swatch.



Other finishes available with extended lead times at no added cost. Custom finishes are available with extended lead time and additional cost. Contact Cornell when color is critical and for additional details.

## Key Product Components/Construction

**Sound Blocker Lining** (TranZform Sound units only) - Both interior panel surfaces are fitted with continuous blankets of sound absorbing material attached with tear resistant fasteners that ensure lasting, effective retention of the sound liner.

**Rollers** - Every panel is fitted with a nylon wheel, ball bearing roller for added wall panel support and smooth operation. Lead posts are fitted with heavy duty trolleys that have multiple sets of dual rollers.

**Lead Post** - Heavy duty extruded aluminum shapes fitted with grip-type handles provide operational support and hook bolt connection to strike posts. Keyed locking is optional, powder coated finish to compliment wall panels.

**Strike Post** (shown) / **Bi-Parting Post** (not shown) - Heavy duty extruded aluminum shapes with hook bolt strike to seal tight with the lead post. Bi-part posts are fitted with grip-type handles and provide operational support. Powder coated finish to compliment wall panels.

**Panels** - Continuous roll formed corrugated steel for strength. Customer selected permanently bonded vinyl finishes allow personalization. Space units feature bonded vinyl finish on public side, platinum gray painted finish opposite side.

**Hinges** - Full height extruded vinyl hinges are rugged for lasting performance and allow for simple panel replacement with units mounted in place. Color matched to compliment wall panels.

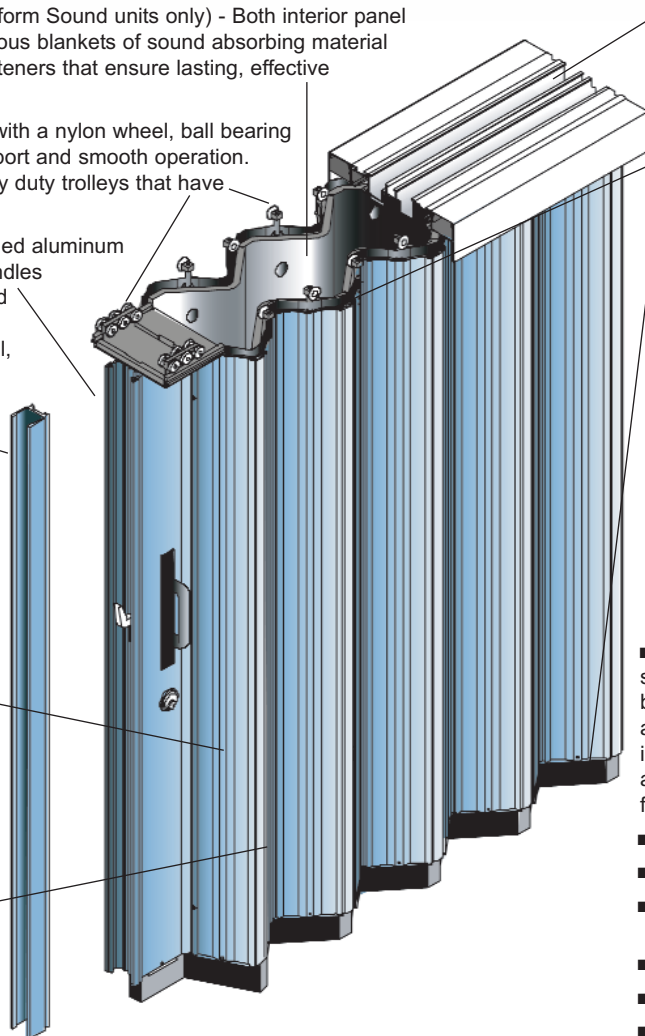

(TranZform Sound unit shown, TranZform Space units similar, but are single wall construction)

**Track** - Heavy duty extruded aluminum or steel shape to support and retain the roller assemblies. Multiple types are available for varying field ceiling construction. Header support construction is not by Cornell.

**Header and Floor Sweeps** - Flexible extruded vinyl seals are attached to the top and bottom of the panels to eliminate gaps at the floor and head area.

**End Member Post** - Used to attach the stack side(s) of the unit to the wall jamb to provide a full height, secured and sealed fit. (Not shown in illustration)

**TranZform Sound Stabilizer Bar Support** - Provided with all motorized units and for units greater 12' tall or when greater than 30' wide. Is a concealed, internally mounted diagonal support positioned from an independent trolley to the lead post to provide reinforced vertical alignment during operation and latching. (Not shown in illustration)

## Product Options

- **Pocket Door** - A heavy duty 12 gauge steel pocket door and frame assembly can be provided to neatly close off the pocket area of a stored partition. A powder coat finish is standard in gray or in an optional color as selected by the customer. Consult factory for pocket doors over 12' tall.
- Single Slide or Bi-Parting Construction
- Integral Header Track Design
- Header Trim and Track Types including Curved Track    ■ Finish Colors
- Motor Operated Sound Units
- Locking at Lead Post: key cylinder, thumb turn
- Fixed or Floating Jamb Construction

**TRANZFORM SOUND DOOR PROFILE WIDTHS**

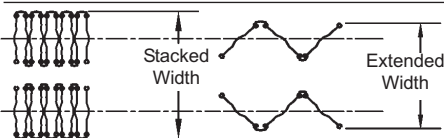

**DOOR PROFILE WIDTHS:**  
 Manual Operated Doors Below 12' H:  
 Stacked Width: 11.56" Extended Width: 10.25" to 10.875"  
 Motorized Doors & Manual Operated Doors Above 12' H or 30' W:  
 Stacked Width: 13.56" Extended Width: 12.25" to 12.875"

**TRANZFORM SOUND PLAN VIEW SINGLE SLIDE, FIXED JAMB**

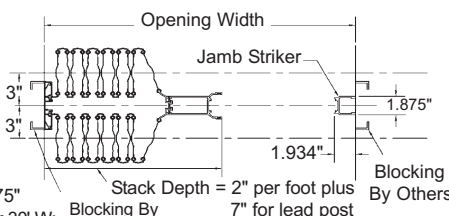

**TRANZFORM SOUND PLAN VIEW BI-PART, FIXED JAMB**

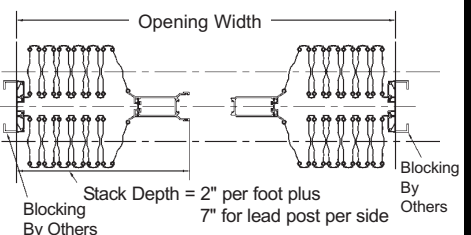

### Practical Product Applications

Use TranZform Sound and Space units whenever there is a need for flexibility of building space. Quickly "transform" a large room into two or more independent spaces as desired or use for off hour pedestrian control.

- Religious facilities
- Educational & Government facilities
- Community centers
- Healthcare facilities
- Hotel multi-function rooms
- Conference centers
- Airports
- Museums
- Public and private office buildings
- Theaters

### Competitive Points of Difference

- Do not utilize a pantograph style frame system - no internal parts to break or get damaged by impact.
- Every panel is track supported by a smooth glide nylon wheel, ball bearing roller assembly.
- Modular construction allows for simple, in-place cost effective installation and service.
- Quality Components: Heavy duty roller with steel hanger pin assembly, mechanically secured hinges and drive chain configuration all ensure long life.
- Corrugated steel panels add strength and durability. Sound and Space units are coated with a scratch resistant, permanently bonded decorative vinyl finish.
- TranZform partitions are installed by Cornell's national network of over 250 distributors.



### The Cornell Advantage

#### Durability

Cornell accordion partitions are designed and constructed to last. Panels are roll-formed from 24 gauge vinyl coated steel into a corrugated pattern with rolled end beads for added strength and durability. Panels offer a high level of impact resistance, warding off dents and scratches. Nylon wheel, ball bearing rollers are utilized for quiet, smooth operation and are positioned on every panel for optimum and lasting performance. Lead and end posts are constructed of heavy duty extruded aluminum shaped sections.

#### Field Friendly Repairs

Although built for lasting performance, Cornell considered ease of service to products installed in the field. With the unit in place, one or multiple panels can be easily replaced by removing and replacing flexible vinyl hinges. Service section of track is provided and installed to allow panel section repair or replacement without removing the entire unit.

#### Cornell Quality Warranty

Materials are warranted against product defects and workmanship for a period of 24 months from date of shipment.

#### Smooth Glide Operation

Nylon wheel, ball bearing rollers attach to every panel and ride in a supporting shaped extruded aluminum track providing optimum operation of the unit. Larger TranZform Sound units incorporate a stabilizer bar to distribute even forces across the entire height of the lead member. Manual push/pull operation is accomplished with minimal effort.

#### Installation

Cornell is very mindful of installation labor costs and is industry leading in limiting field installation steps by assembling all that is possible in their factory controlled environment. In most cases, Cornell accordion partitions are easily installed by a two person crew without special equipment.

#### Cornell Value

With more than 180 years of experience with supplying building products to the construction industry, Cornell understands satisfying customers. From the onset of a project through the life cycle of the product, Cornell provides an unprecedented value experience to their customers.

### Design Review

**Stacking Requirements** - Cornell accordion partitions are designed to stack at a fraction of their extended width. Approximate stack space can be calculated as follows:  
TranZform Space stack area = 1 3/4" per foot of width + 5 1/2"  
TranZform Sound stack area = 2" per foot of width + 7"  
(Note: for Sound units above 12' high or 30' wide, minimum stack area is 43" per stacking area)

**Hang Weight** - Cornell accordion partitions are designed with the perfect balance of materials for minimal hang weight, ease of operation and optimal durability. TranZform Space units have an approximate hang weight of 1.9 pounds per square foot and TranZform Sound units are approximately 4.5 pounds per square foot, extended positions.

#### Performance Ratings & Code Compliance

TranZform partitions Surface Burning Characteristics per ASTM E 84 have a Flame Spread Index of less than 20 and a Smoke Developed Index of less than 60. TranZform Space units are STC 30 rated per ASTM E 90, Sound units are STC 45.

# CORNELL

**SAFE AND SECURE**

An ISO 9001:2008 Registered Company

Crestwood Industrial Park, Mountaintop, PA 18707

800.233.8366 • 570.474.6773 • Fax: 800.526.0841 • Email: ADS@cornelliron.com

[www.cornelliron.com](http://www.cornelliron.com)

