



INSTALLATION INSTRUCTIONS

AND

OPERATION MANUAL

Cornell MG Operator

MGR/ MGH Series

IMPORTANT INSTALLATION INSTRUCTIONS

WARNING - To reduce the risk of severe injury or death:

1. READ AND FOLLOW ALL INSTALLATION INSTRUCTIONS.
2. Install only on a properly operating and balanced door. A door that is operating improperly could cause severe injury. Have qualified service personnel make repairs to cables, spring assemblies, and other hardware before installing the operator.
3. Remove all pull ropes and remove, or make inoperative, all locks (unless mechanically and/or electrically interlocked to the power unit) that are connected to the door before installing the operator.
4. Install the door operator at least 8 feet or more above the floor if the operator has exposed moving parts.
5. Do not connect the door operator to the source of power until instructed to do so.
6. Locate the control station: (a) within sight of the door, (b) at a minimum height of 5 feet so small children cannot reach it, and (c) away from all moving parts of the door.
7. Install the Entrapment Warning Placard next to the control station in a prominent location.
8. For products having a manual release, instruct the end user on the operation of the manual release.
9. The door is under extreme spring tension. Have qualified door mechanics make all necessary adjustments and repairs to the door.
10. Make sure the available power supply to be connected to the operator is of the same voltage, frequency, phase and wattage as indicated on the nameplate of the operator.
11. Read and understand the wiring diagram of the operator and the control station (open-close-stop push button), and any other equipment to be connected to the operator.
12. To avoid damage to the door and operator, make all door locks inoperative. Secure locks in the unlocked position, or install external electrical interlocks to prevent operation with the locks engaged. NOTE – MGRL/MGHL series have internal lock sensor feature.
13. Always disconnect power whenever installing or servicing the door operator or door.
14. All wiring is to comply with National Electrical Code (NEC) and local code requirements.
15. Any change in mounting position may result in change of operator rotation and consequently in change of control functions. Consult factory for any changes.
16. Hand Chain must be kept inside plastic bag when operating electrically.

SPECIFICATIONS

MOTOR

Type: Restricted cycle duty
(20 cycles per hour/20,000 cycles max.)

Horsepower: 1/3hp, 1/2hp, 3/4hp

Speed: 1700 RPM

Voltage: 115, 230 – 1 phase
208/230, 460 – 3 phase
230 volt 3 phase motor is suitable for use with 208 volts

Current: See motor nameplate

ELECTRICAL

Transformer: 24VAC

Wiring Type: Momentary pressure open, stop, constant pressure close
(provided standard), with provision for momentary
pressure close*

Limit Adjustment: Linear driven, fully adjustable screw type cams.

MECHANICAL

Drive reduction: 43:1

Output shaft speed: 40 RPM

Door Speed: 6 - 9" per sec. average (typical)

Brake: Solenoid actuated brake

Release Mechanism: Floor level pull-cable release standard

Emergency Chain Hoist: Optional

ENTRAPMENT PROTECTION

Sensing Edge*: (Optional) Sensing device attached to the bottom edge of
the door.

*** Per the requirements of UL Standard 325, the door operator must be provided with an actuating device requiring constant pressure to close the door. As an alternative, the door may be provided with a device that will reverse the door upon contact with an obstruction during closing.**

INSTALLATION INSTRUCTIONS

INSTALLATION POSITIONS

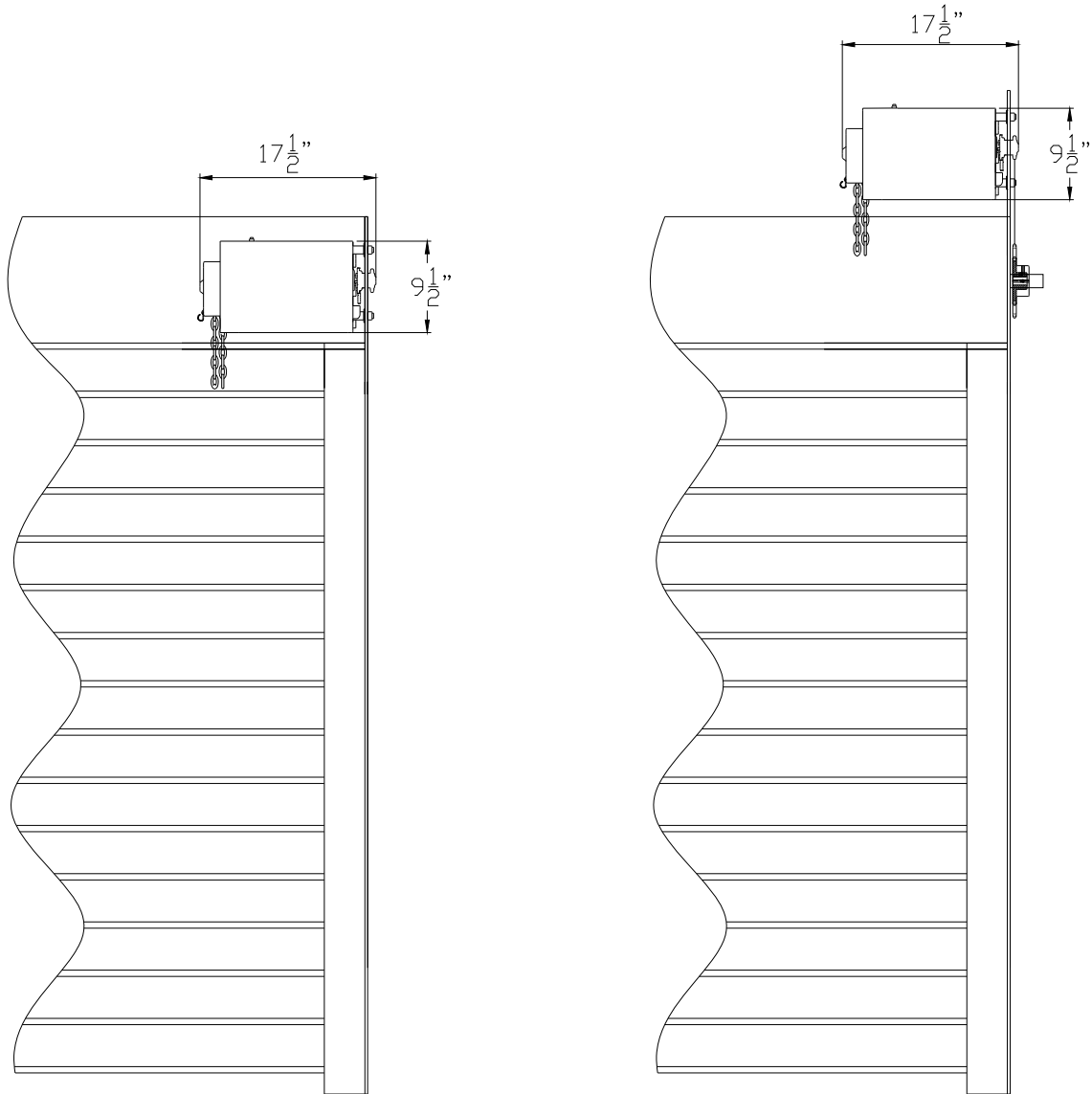
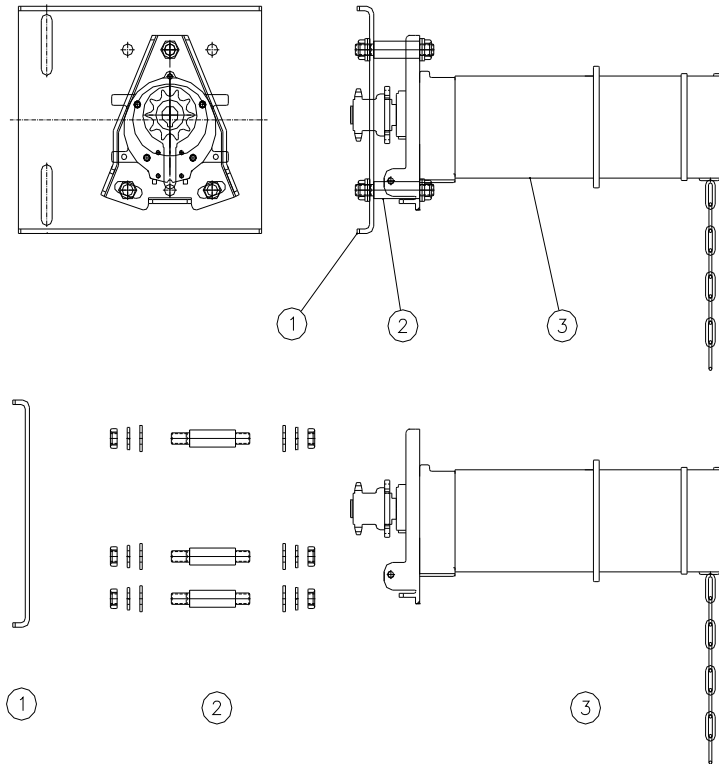

Illustration only. Consult factory for changes in installation positions.

NOTE: Any change in mounting position may result in change of operator rotation and consequently in change of control functions (i.e. lock sensor). Consult factory for any changes.

OPERATOR MOUNTING

1. Before the operator is installed, verify that the door is properly operating and balanced.
2. Make sure the dimensions of mounting holes on the bracket are correct.
3. Attach and tighten the three legs (2) to the mounting plate.
4. Bolt the operator mounting plate (1) to the door bracket plate.
5. Finally, mount the operator (3) to the three legs (2) and tighten.



6. When the operator is mounted on the bracket, be sure the door driven sprocket is properly aligned with the operator drive sprocket before securing to the shaft. The clearance (B) must be the same as the height (A).

7. The shelf or bracket must provide adequate support for the operator. Prevent play between operator and door shaft. Permit operator to be fastened securely and with the drive shaft parallel to the door shaft. It may be necessary to field brace the operator/bracket.

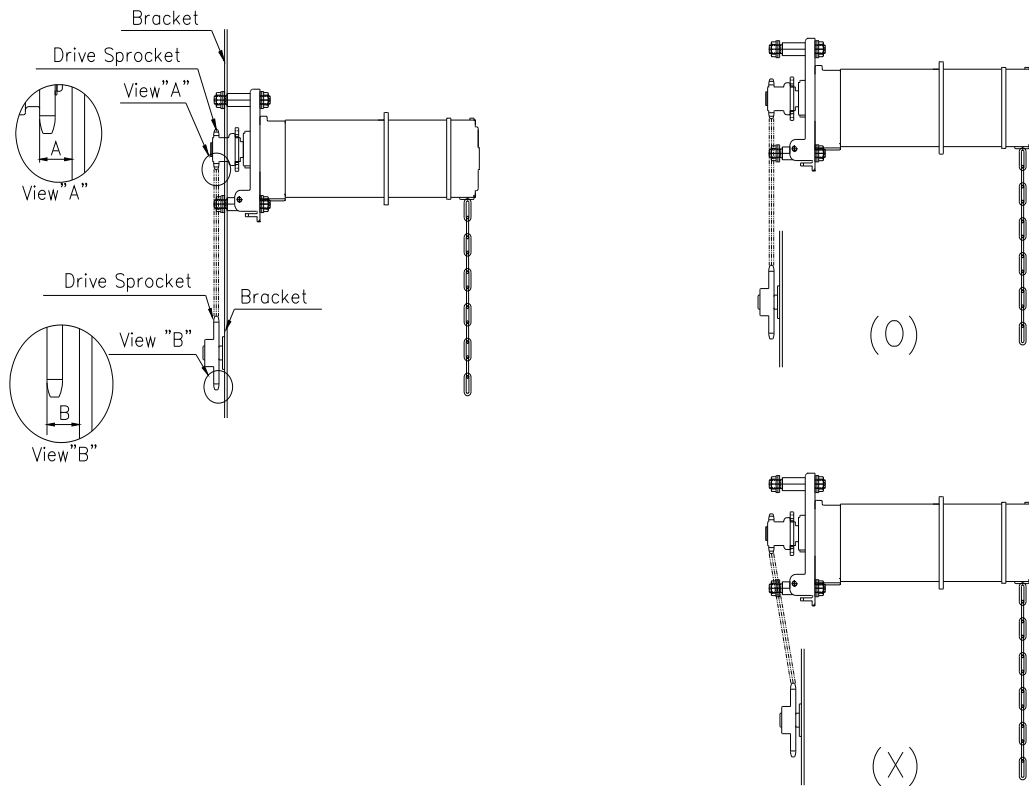

DRIVE CHAIN ADJUSTMENT

NOTE: Use correct type, size and proper length of roller chain.

1. Adjust the drive chain by tilting the operator so that there is about 1/4" of slack when the chain is depressed.

Note: The set screw included in the operator may be used for adjustment (S1 location).

2. Once the drive chain has been tightened and the base leg screws have been set, and then tighten the operator screws.

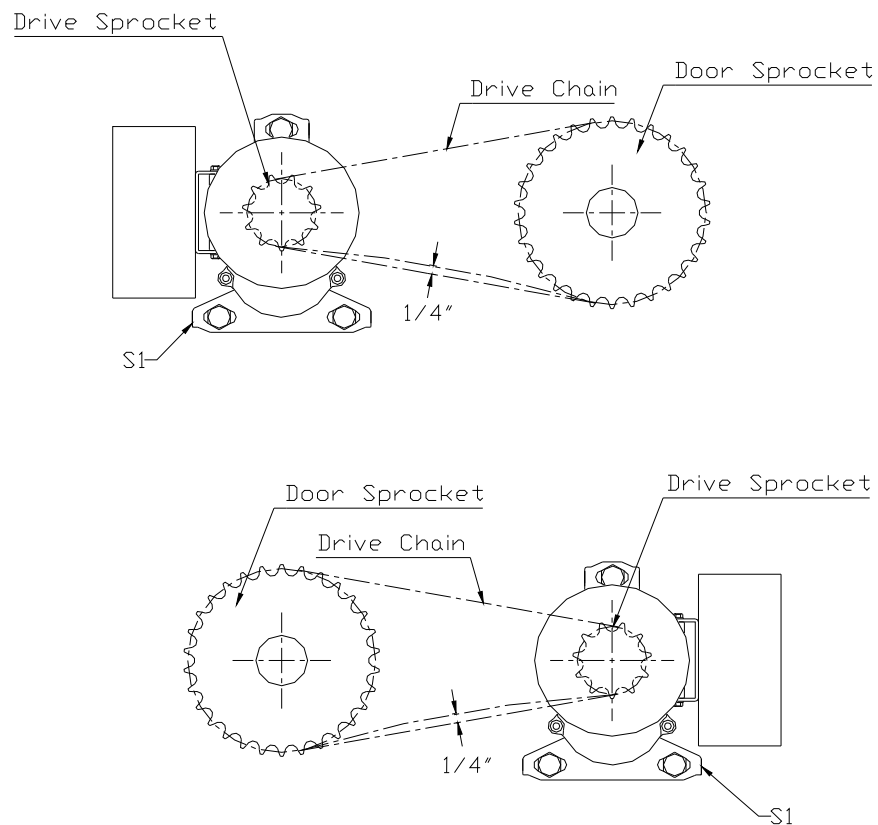

MANUAL RELEASE

Cut and adjust cable length.

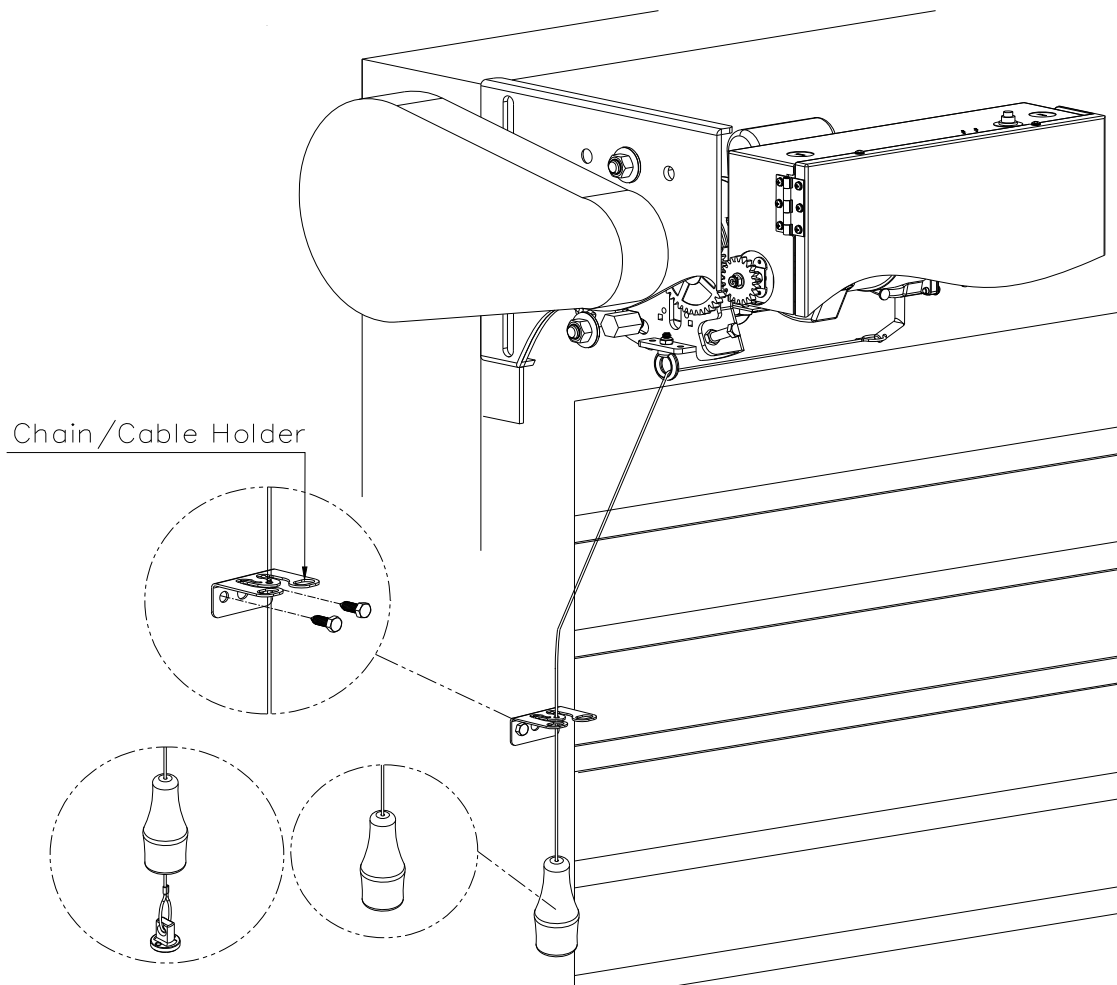

EMERGENCY HAND CHAIN ADJUSTMENT (OPTIONAL on MGR Series)

Cut and reconnect chain with different color link provided.

WARNING: When using hand chain, a dis/engagement cable is not required and should not be used. Use cable only on operators without an auxiliary hand chain (MGR) or when a pull handle egress device is used in conjunction with an auxiliary hand chain on the MGH.

Note: Chain hoist can be added in the field. Consult factory for details.

LIMIT SWITCH ADJUSTMENT

Make sure the limit cams are positioned between the limit switch actuators before proceeding with adjustments.

1. Open / Remove the control panel cover.
2. Open or close door to determine the moving direction of the limit switch cams.
3. Open or close door to the desired position.



If the door is opened or closed electrically, to avoid serious injury or death, disconnect power before manually moving limit switch cams.

4. While pressing the spring-loaded lever (G), which holds the limit switch cams in place, adjust the limit switch cam (E or F) until the micro switch (C or D) clicking sound is heard.
5. If the limit switch cam cannot be rotated to its desired position, release the lever and move the door away from the desired position, then adjust the limit switch cam to its desired position. It may be necessary to repeat this step until the exact position has been reached.
6. Repeat step 3 and 4 for the opposite position. Adjust close limit cams so that actuator is engaged as door fully seats at the floor.
7. Micro switch (A or B) can be adjusted to accommodate sensing edge cut-off position.

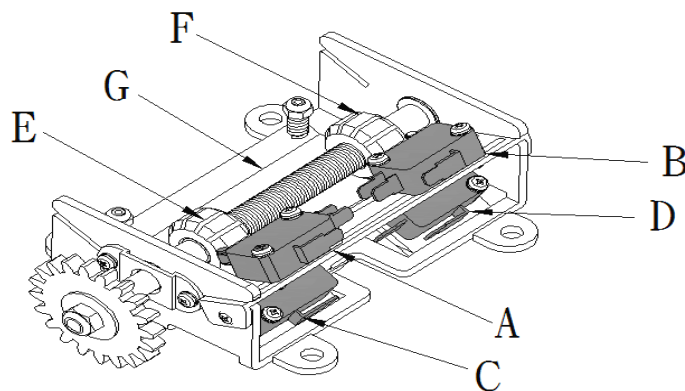

NOTE: “C” is usually the opening side and “D” is usually the closing side.

WIRING INSTRUCTIONS



Disconnect power at the fuse box and the operator before proceeding with any wiring.

1. Do not install any wiring or attempt to run this operator without checking the wiring diagram located on the inside of the control box cover.
2. Do not turn on power until you have finished making all power and control wiring connections.
3. Do not run power and control wiring in the same conduit.
4. Any wire connecting to the control panel must be protected by conduit or other means to ensure the safety and permanency of the wiring.
5. Use copper wire inside the control panel.
6. A separate fuse line of adequate capacity is needed for the operator.
7. The operator must be properly grounded. The ground screw, plated green, is located inside the control panel.



Failure to properly ground the operator could result in electric shock and serious injury or death.



To avoid damage to door and operator, make all door locks inoperative. Secure lock(s) in the unlocked position, or install electrical interlocks to prevent operation with the lock engaged. Note: MGRL / MGHL series have internal lock sensor feature.

CONTROL WIRING



Disconnect power at the fuse box before proceeding with any wiring.

1. Locate the control station where the user can clearly see the operation of the door. Mount the enclosed placard adjacent to the 3-button control station.



If the door is not visible from the control station, or if any device other than the control station is used to activate the door, a sensing edge must be installed on the bottom of the door. Failure to install a sensing edge may result in serious injury or death to person(s) trapped beneath the door.

Complete limit switch adjustments before making any sensing edge wiring connections to the operator.

2. Do not run control wiring in the same conduit as power wiring.
3. Any wire connecting to the control panel must be protected by conduit or other means to ensure the safety and permanency of the wiring.



Do not use radio controls with your operator unless some type of entrapment protection device has been installed. Failure to do so may result in serious injury or death to person(s) trapped beneath the door.



Do not change closing control from constant pressure to momentary pressure without installing a sensing edge. This could result in serious injury or death to person(s) trapped beneath the door.



Changing from left hand to right hand or vice versa could result in change of control wiring and lock sensor settings. Please consult factory for details.

4. After installation, be sure that the operator, lock sensor, controls, and sensing edge or other entrapment protection devices have been tested and function properly.

MGR and MGH 115V 1 Phase LH
 (For MGR and MGH 3311, 5011, 7511)

EM 104 L

NOTES:

- UP-OPEN RELAY (COIL 24VAC)
- DN-CLOSE RELAY (COIL 24VAC)
- LSA-LS1 & LS3 MICROSWITCH CONNECTOR
- LSB-LS2 & LS4 MICROSWITCH CONNECTOR
- LSC-OPEN CONTROL CONNECTOR
- LSD-CLOSE CONTROL CONNECTOR

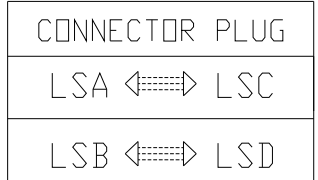
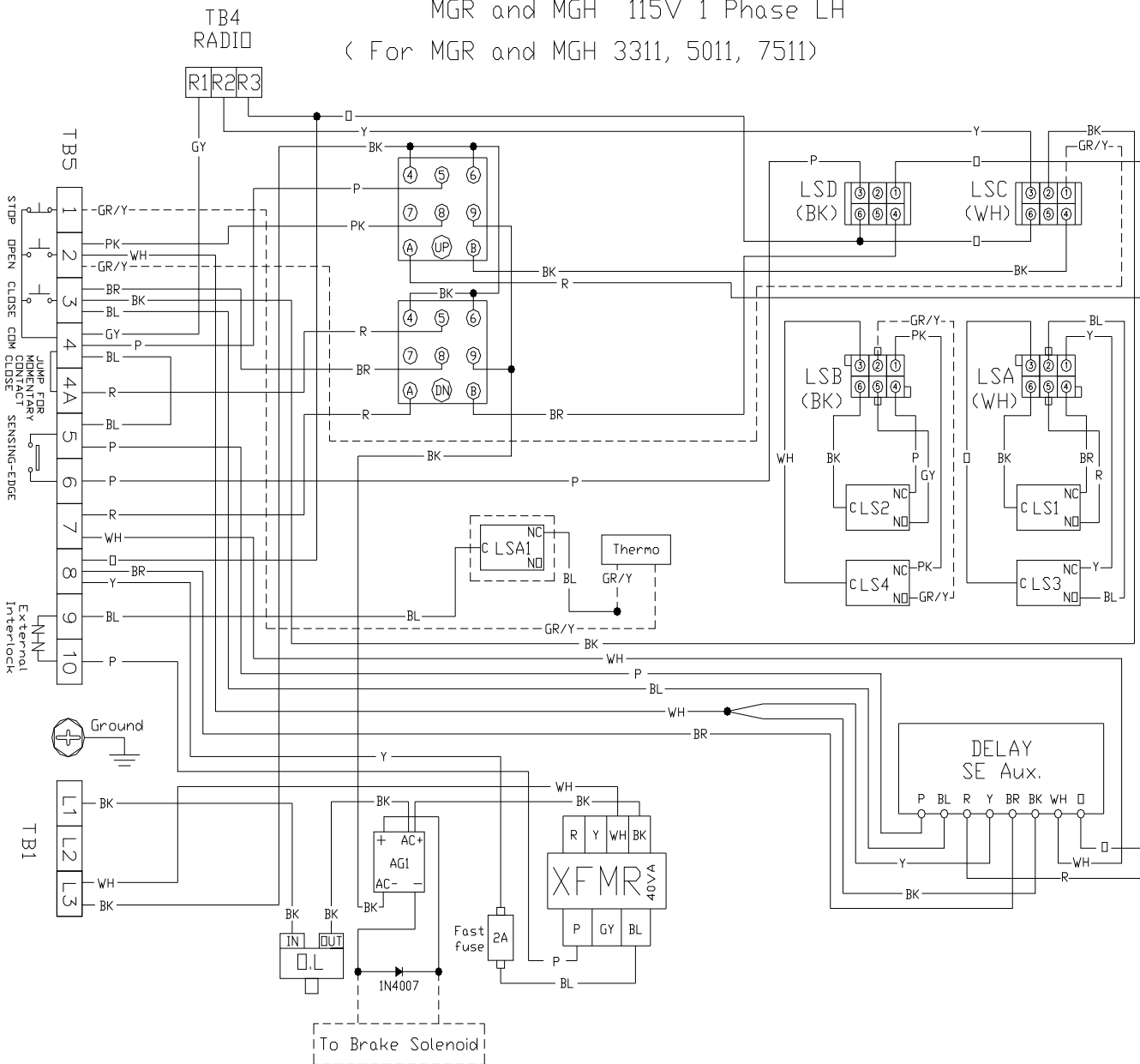

LSA1-MANUAL CUT-OFF MICROSWITCH

TERMINAL NUMBER:

- 1 CONTROL STATION-STOP
- 2 CONTROL STATION-OPEN
- 3 CONTROL STATION-CLOSE
- 4 CONTROL STATION-COMMON
- 4&4A JUMP FOR MOMENTARY CONTACT CLOSE
- 5&6 SENSING-EDGE (S.E.) CONNECTION
- 7&8 DOOR CLOSING WARNING SIGNAL 24VAC
- 9&10 EXTERNAL INTERLOCK

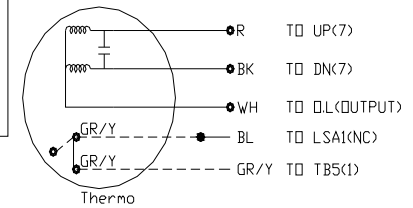

115V 1 PHASE
 MOTOR CONNECTION

2008.03.05

MGR and MGH 115V 1 Phase RH
 (For MGR and MGH 3311, 5011, 7511)

EM 104 R

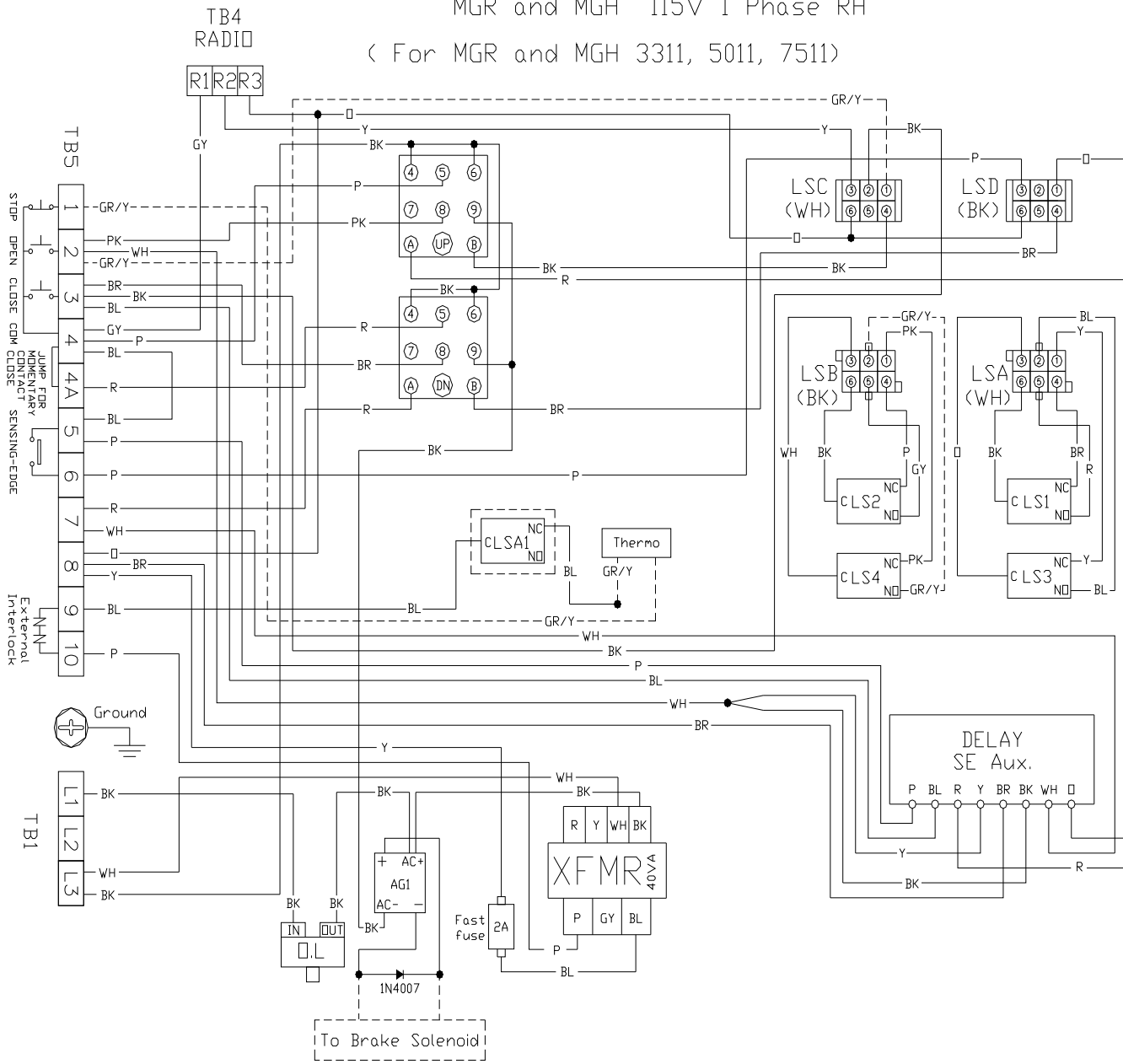

NOTES:

- UP-OPEN RELAY (COIL 24VAC)
- DN-CLOSE RELAY (COIL 24VAC)
- LSA-LS1 & LS3 MICROSWITCH CONNECTOR
- LSB-LS2 & LS4 MICROSWITCH CONNECTOR
- LSC-OPEN CONTROL CONNECTOR
- LSD-CLOSE CONTROL CONNECTOR

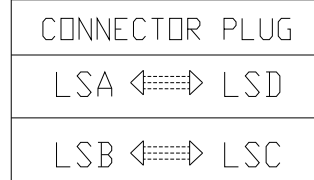

LSA1-MANUAL CUT-OFF MICROSWITCH

TERMINAL NUMBER:

- 1 CONTROL STATION-STOP
- 2 CONTROL STATION-OPEN
- 3 CONTROL STATION-CLOSE
- 4 CONTROL STATION-COMMON
- 4&4A JUMP FOR MOMENTARY CONTACT CLOSE
- 5&6 SENSING-EDGE (S.E.) CONNECTION
- 7&8 DOOR CLOSING WARNING SIGNAL 24VAC
- 9&10 EXTERNAL INTERLOCK

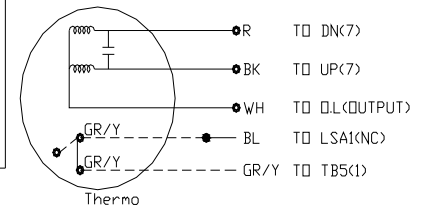

115V 1 PHASE
 MOTOR CONNECTION

2008.03.05

MGR and MGH 230V 1 Phase LH
 (For MGR and MGH 3321, 5021, 7521)

EM 204 L

NOTES:

- UP-OPEN RELAY (COIL 24VAC)
- DN-CLOSE RELAY (COIL 24VAC)
- LSA-LS1 & LS3 MICROSWITCH CONNECTOR
- LSB-LS2 & LS4 MICROSWITCH CONNECTOR
- LSC-OPEN CONTROL CONNECTOR
- LSD-CLOSE CONTROL CONNECTOR

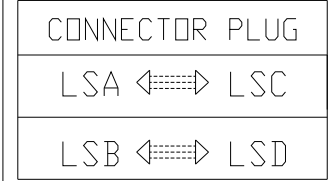
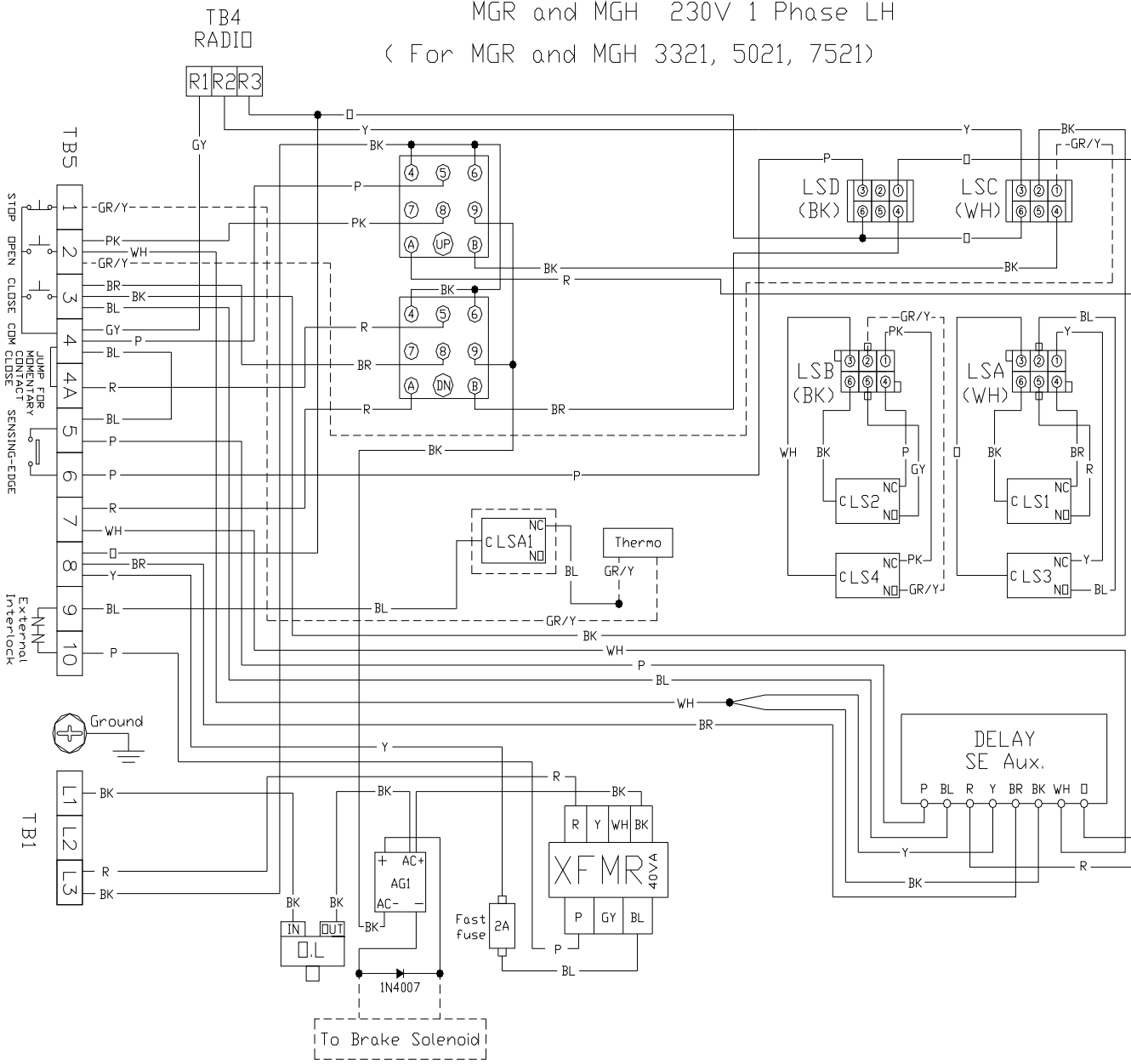

LSA1-MANUAL CUT-OFF MICROSWITCH

- TERMINAL NUMBER:
- 1 CONTROL STATION-STOP
 - 2 CONTROL STATION-OPEN
 - 3 CONTROL STATION-CLOSE
 - 4 CONTROL STATION-COMMON
 - 4&4A JUMP FOR MOMENTARY CONTACT CLOSE
 - 5&6 SENSING-EDGE (S.E.) CONNECTION
 - 7&8 DOOR CLOSING WARNING SIGNAL 24VAC
 - 9&10 EXTERNAL INTERLOCK

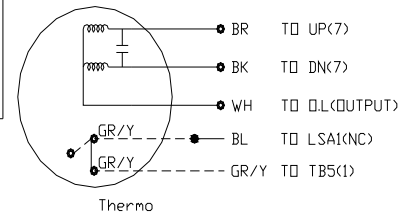

230V 1 PHASE
 MOTOR CONNECTION

2008.03.05

MGR and MGH 230V 1 Phase RH
(For MGR and MGH 3321, 5021, 7521)

EM 204 R

NOTES:

- UP-OPEN RELAY (COIL 24VAC)
- DN-CLOSE RELAY (COIL 24VAC)
- LSA-LS1 & LS3 MICROSWITCH CONNECTOR
- LSB-LS2 & LS4 MICROSWITCH CONNECTOR
- LSC-OPEN CONTROL CONNECTOR
- LSD-CLOSE CONTROL CONNECTOR

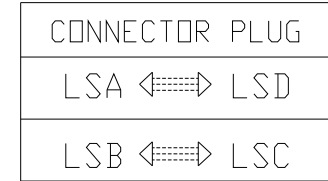

LSA1-MANUAL CUT-OFF MICROSWITCH

TERMINAL NUMBER:

- 1 CONTROL STATION-STOP
- 2 CONTROL STATION-OPEN
- 3 CONTROL STATION-CLOSE
- 4 CONTROL STATION-COMMON
- 4&4A JUMP FOR MOMENTARY CONTACT CLOSE
- 5&6 SENSING-EDGE (S.E.) CONNECTION
- 7&8 DOOR CLOSING WARNING SIGNAL 24VAC
- 9&10 EXTERNAL INTERLOCK

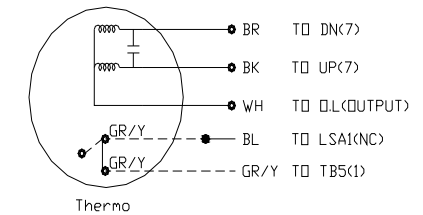

230V 1 PHASE
MOTOR CONNECTION

2008.03.05

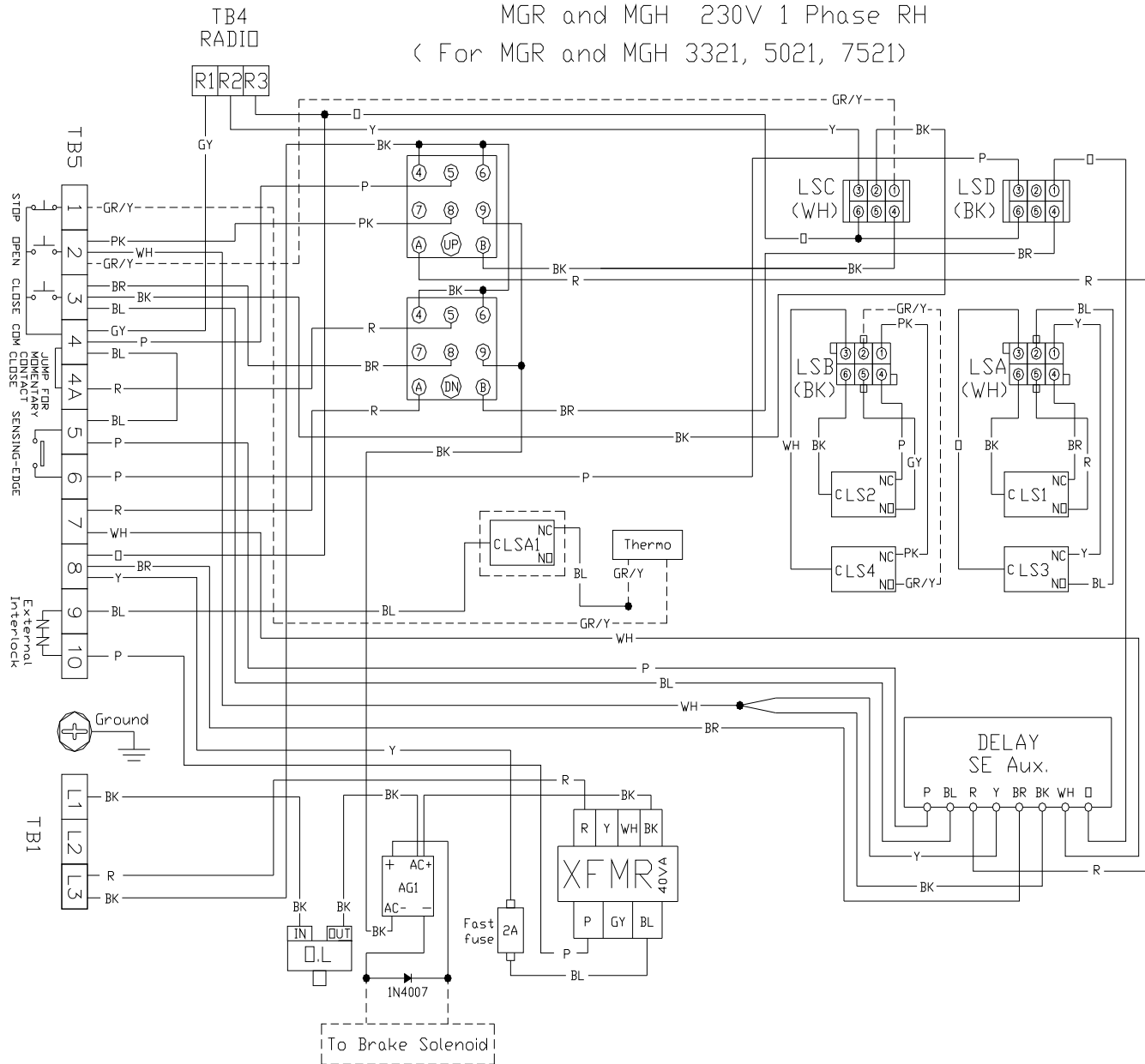

MGR and MGH 208V/230V 3 Phase LH
(For MGR and MGH 3323, 5023, 7523)

EM 304 L

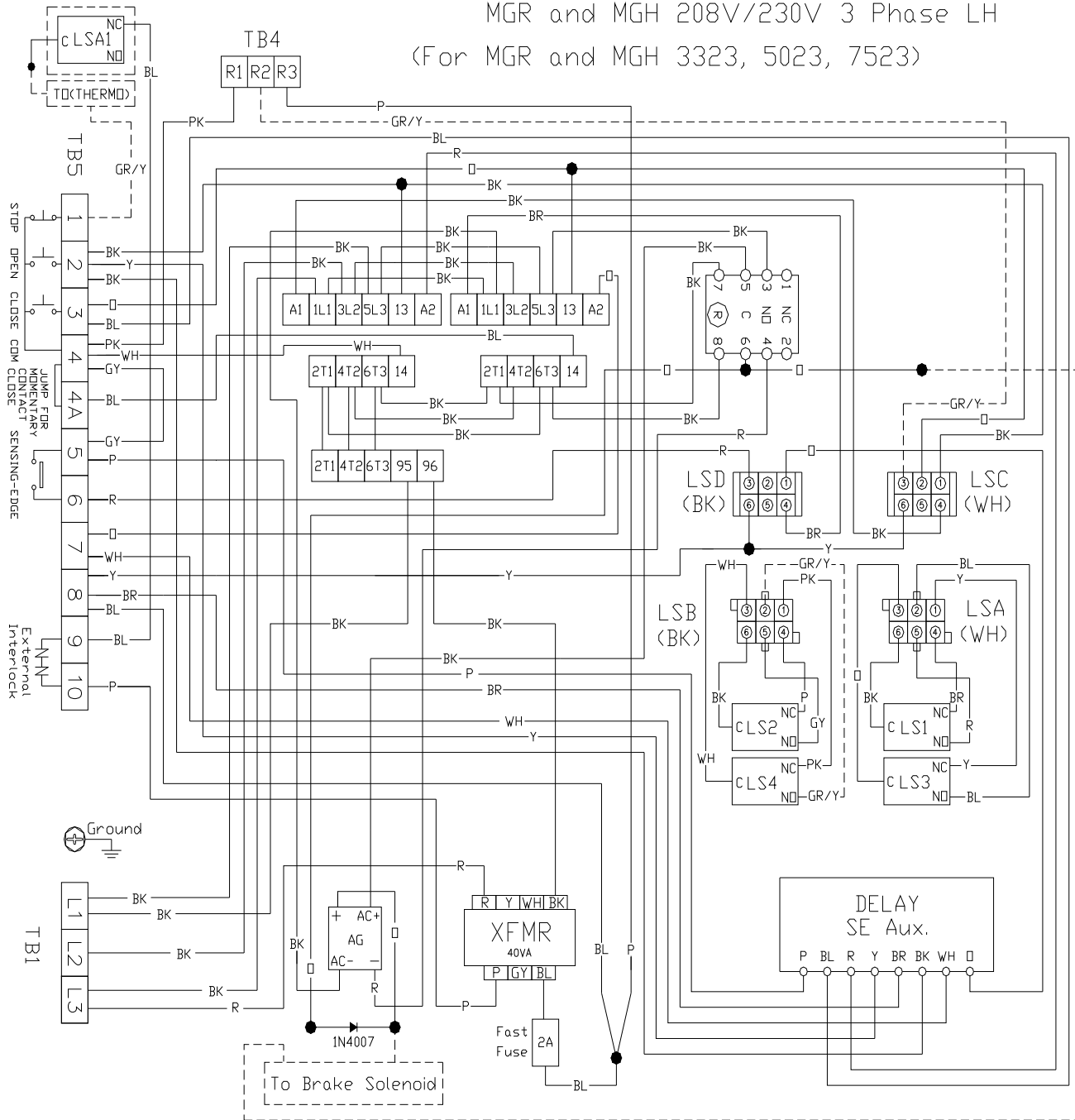

NOTES:

- R-BRAKE-COIL 220VAC
- LSA-LS1 & LS3 MICROSWITCH CONNECTOR
- LSB-LS2 & LS4 MICROSWITCH CONNECTOR
- LSC-OPEN CONTROL CONNECTOR
- LSD-CLOSE CONTROL CONNECTOR

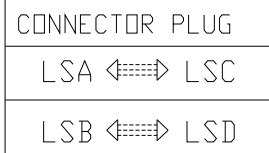

LSA1-MANUAL CUT-OFF MICROSWITCH

TERMINAL NUMBER:

- 1 CONTROL STATION-STOP
- 2 CONTROL STATION-OPEN
- 3 CONTROL STATION-CLOSE
- 4 CONTROL STATION-COMMON
- 4&4A JUMP FOR MOMENTARY CONTACT CLOSE
- 5&6 SENSING-EDGE (S.E.) CONNECTION
- 7&8 DOOR CLOSING WARNING SIGNAL 24VAC
- 9&10 EXTERNAL INTERLOCK

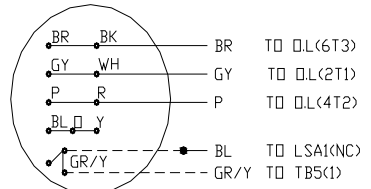

(Thermo)
208V/230V 3 Phase
MOTOR CONNECTION

2008.03.05

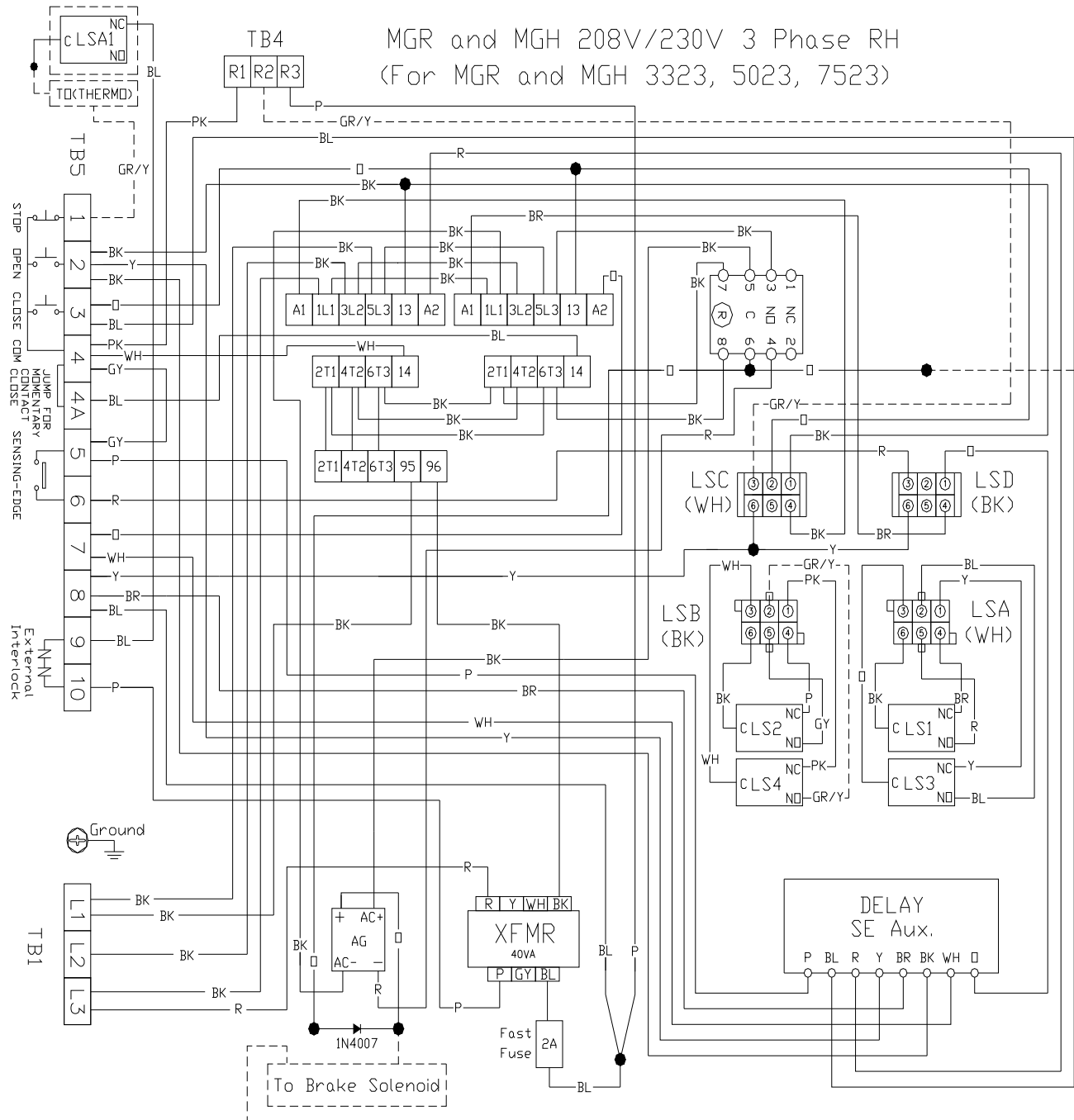

MGR and MGH 208V/230V 3 Phase RH
(For MGR and MGH 3323, 5023, 7523)

EM 304 R

NOTES:

- R-BRAKE-COIL 220VAC
- LSA-LS1 & LS3 MICROSWITCH CONNECTOR
- LSB-LS2 & LS4 MICROSWITCH CONNECTOR
- LSC-OPEN CONTROL CONNECTOR
- LSD-CLOSE CONTROL CONNECTOR

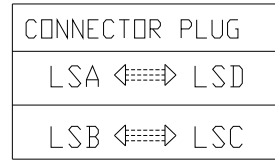

LSA1-MANUAL CUT-OFF MICROSWITCH

TERMINAL NUMBER:

- 1 CONTROL STATION-STOP
- 2 CONTROL STATION-OPEN
- 3 CONTROL STATION-CLOSE
- 4 CONTROL STATION-COMMON
- 4&4A JUMP FOR MOMENTARY CONTACT CLOSE
- 5&6 SENSING-EDGE (S.E.) CONNECTION
- 7&8 DOOR CLOSING WARNING SIGNAL 24VAC
- 9&10 EXTERNAL INTERLOCK

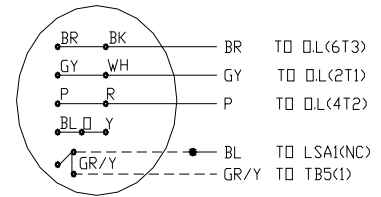

(Thermo)

208V/230V 3 Phase
MOTOR CONNECTION

2008.03.05

MGR and MGH 460V 3 Phase LH
(For MGR and MGH 3343, 5043, 7543)

EM 404 L

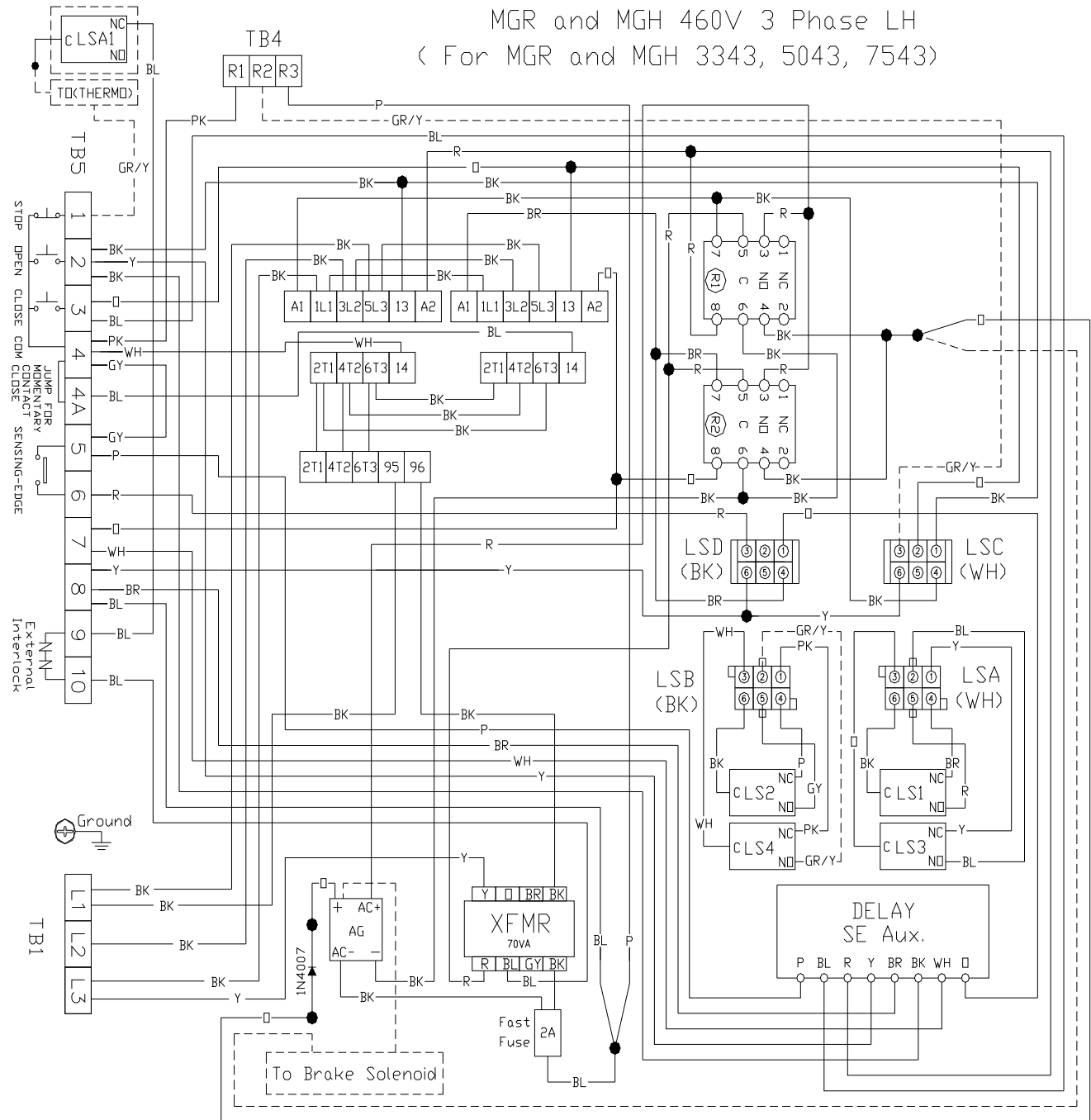

NOTES:

- R1-COIL 24VAC
- R2-COIL 24VAC
- LSA-LS1 & LS3 MICROSWITCH CONNECTOR
- LSB-LS2 & LS4 MICROSWITCH CONNECTOR
- LSC-OPEN CONTROL CONNECTOR
- LSD-CLOSE CONTROL CONNECTOR

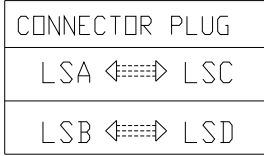

LSA1-MANUAL CUT-OFF MICROSWITCH

TERMINAL NUMBER:

- 1 CONTROL STATION-STOP
- 2 CONTROL STATION-OPEN
- 3 CONTROL STATION-CLOSE
- 4 CONTROL STATION-COMMON
- 4&4A JUMP FOR MOMENTARY CONTACT CLOSE
- 5&6 SENSING-EDGE (S.E.) CONNECTION
- 7&8 DOOR CLOSING WARNING SIGNAL 24VAC
- 9&10 EXTERNAL INTERLOCK

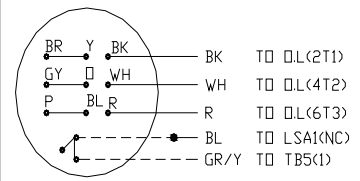

(Thermo)

460V 3 Phase
MOTOR CONNECTION

2008.03.05

MGR and MGH 460V 3 Phase RH
 (For MGR and MGH 3343, 5043, 7543)

EM 404 R

- NOTES:
 R1-COIL 24VAC
 R2-COIL 24VAC
 LSA-LS1 & LS3 MICROSWITCH CONNECTOR
 LSB-LS2 & LS4 MICROSWITCH CONNECTOR
 LSC-OPEN CONTROL CONNECTOR
 LSD-CLOSE CONTROL CONNECTOR

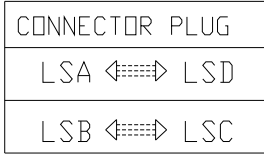

- TERMINAL NUMBER:
 1 CONTROL STATION-STOP
 2 CONTROL STATION-OPEN
 3 CONTROL STATION-CLOSES
 4 CONTROL STATION-COMMON
 4&4A JUMP FOR MOMENTARY CONTACT CLOSE
 5&6 SENSING-EDGE (S.E.) CONNECTION
 7&8 DOOR CLOSING WARNING SIGNAL 24VAC
 9&10 EXTERNAL INTERLOCK

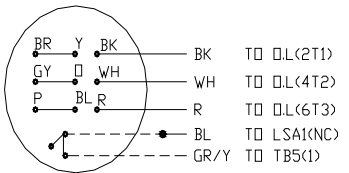

(THERMO)
 460V 3 Phase
 MOTOR CONNECTION

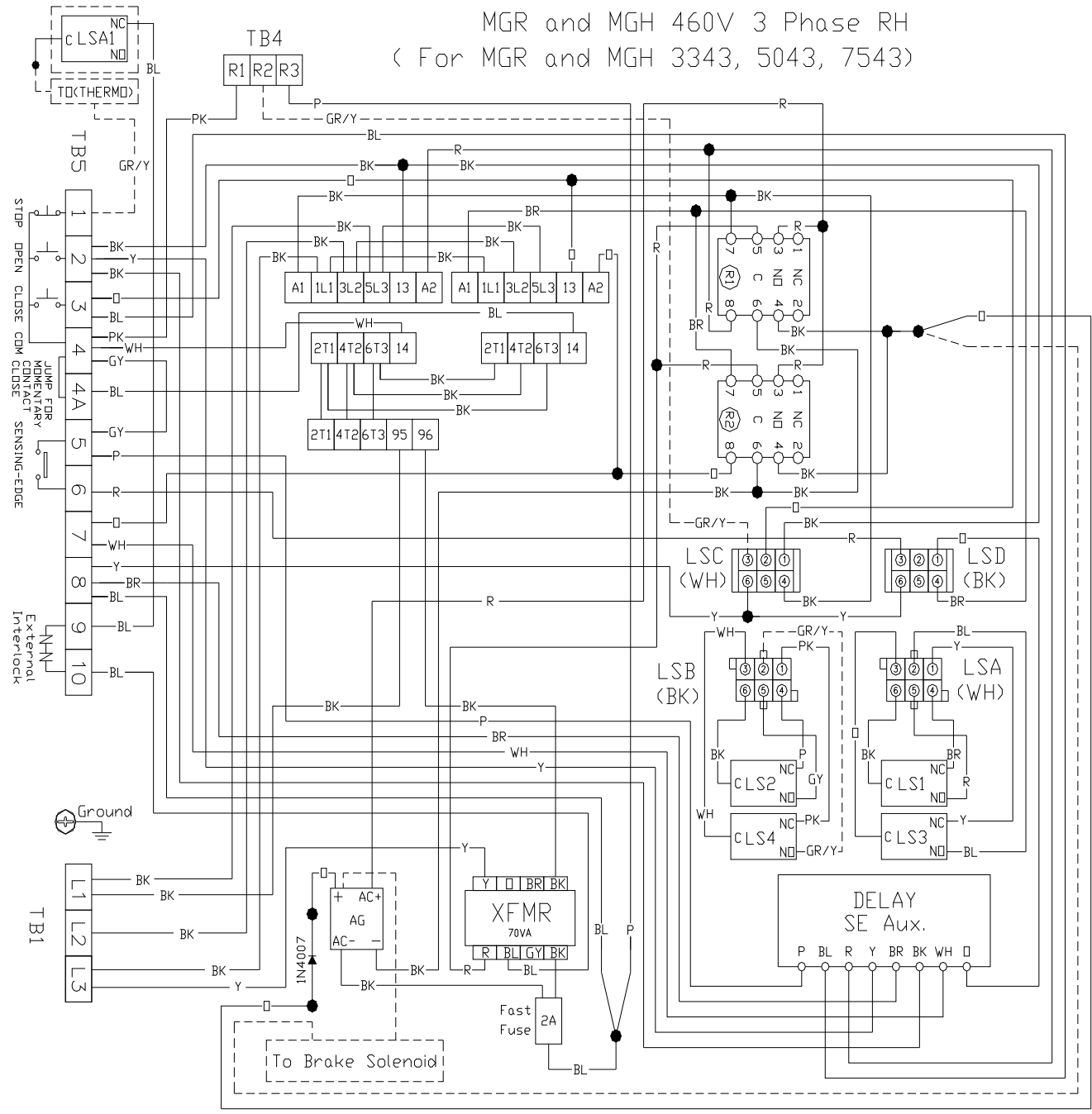

2008.03.05

Reference

MG series terminal connections

1	2	3	4	4A	5	6	7	8	9	10
Control Station					Sensing-edge (S.E.)		Closing door moving warning signal 24VAC		External Interlock	
Stop	Open	Close	Common							
			Add jumper for momentary pressure close	N/O Contact					Jump when no external interlock is connected.	

- ❖ Control panel is wired with momentary pressure open and constant pressure close. By jumping terminal 4 & 4A, the push button will be momentary pressure open and close. Without jumping terminal 4 & 4A, the radio control will **NOT** be functional.
- ❖ A one-second delay on reverse is standard.
- ❖ When the door is closing, pushing the “Open” or “Stop” button will stop the door from moving.
- ❖ When the door is closing, the radio control transmitter can stop and reverse the door at anytime.

IMPORTANT SAFETY INSTRUCTIONS

WARNING – To reduce the risk of severe injury or death:

1. READ AND FOLLOW ALL INSTRUCTIONS.
2. Never let children operate or play with door controls. Keep the remote control (where provided) away from children.
3. Personnel should keep away from a door in motion and keep the moving door in sight until it is completely closed or opened. **NO ONE SHOULD CROSS THE PATH OF A MOVING DOOR.**
4. Test the door's safety features at least once a month. After adjusting either the force or the limit of travel, retest the door operator's safety features. Failure to adjust the operator properly may cause severe injury or death.
5. For products having a manual release, if possible, use the manual release only when the door is closed. Use caution when using this release when the door is open. Weak or broken springs may cause the door to fall rapidly, causing severe injury or death.
6. **KEEP DOORS PROPERLY OPERATING AND BALANCED.** See Door Manufacturer's Owner's Manual. An improperly operating or balanced door could cause severe injury or death. Have trained door systems technician make repairs to cables, spring assemblies, and other hardware.
7. SAVE THESE INSTRUCTIONS.

OPERATING INSTRUCTIONS

1. If a 3-button control station is used to operate the door, push the “OPEN” button to open the door, push the “CLOSE” button to close the door, push the “STOP” button to stop movement of the door while opening or closing. Removing pressure from the “CLOSE” button will cause the door to stop.
2. If a key switch control station is used to operate the door, turn the key to the “OPEN” position to open the door, turn the key to the “CLOSE” position to close the door, push the “STOP” button to stop movement of the door while opening or closing. Removing pressure from the “CLOSE” key position will cause the door to stop.



If a sensing edge is not installed on the bottom of the door, and removing pressure from the “CLOSE” button or key switch position does not cause the door to stop, this condition must be corrected immediately. Improper operation could result in serious injury or death to person(s) trapped beneath the door.

3. Door may also be operated by remote devices.

EMERGENCY MANUAL OPERATION

This operator has provisions for manually operating the door in case of emergency or power failure.

MANUAL RELEASE

Pull cable to release brake; then push the door open or pull it closed.

CHAIN HOIST (OPTIONAL on MGR)

Note: Chain hoist can be added in the field. Consult factory for details.

WARNING: When using hand chain (MGH), a disengagement cable is not required and should not be used. Use cable only when MGH is equipped with a pull handle egress release.

To operate the hoist:

1. Remove the hoist chain from the gray plastic bag.
2. Pull chain to operate the door in the desired direction. (No clutch to engage)

Put chain hoist back into the plastic bag, before the door operates again electrically.



Turn off power to the operator before manually operating the door.



Hand Chain must be kept inside plastic bag when operating electrically.

MAINTENANCE INSTRUCTIONS

The brake is a self-adjusting brake. It is maintenance free. The brake assembly requires no additional adjustments for its lifetime.

If an entrapment protection device is used, i.e. sensing edge or photoelectric sensors, please consult the manufacturer for maintenance instruction.



Disconnect power supply to the operator before servicing.

Check the following items at the intervals listed:

CHECK LIST	DESCRIPTION	EVERY 3 MONTHS	EVERY 6 MONTHS	EVERY 12 MONTHS
Drive Chain	Check for excessive slack. Check & adjust as required Lubricate.	●		
Sprockets	Check set screw tightness	●		
Fasteners	Check & tighten as required		●	
Bearings & Shafts	Check for wear & lubricate	●		

- ❖ Do not lubricate motor. Lubrication could cause damage.
- ❖ Inspect and service whenever a malfunction either door or operator is observed or suspected.
- ❖ Before servicing, always disconnect power supply to the operator.
- ❖ Replace fuses only with those of the same type and rating.
- ❖ All replacement parts must be compatible with those originally provided.



Do not place hands or tools in or near the operator when the power is connected or when testing control or safety devices. Always disconnect power before servicing or adjusting the operator.

U.S. GEAR

Covered under US Pat. #6,900,602, #7,055,283 and additional patents pending