

# Cornell Model MG Operator

## Industrial Duty Gear Head Operators

### Recommended For Up To 20 Cycles Per Day

## Features and Benefits

- Gear Head construction at the price of a belt-drive operator.
- Totally Enclosed Non-Ventilated (TENV) motor provided as standard.
- Compact Operator/Mounting Configuration is ideal for coiling doors - operators always fit within the coil height dimension.
- Consistent Mounting, Appearance, Wiring - across full line of Cornell operator models.
- Considerably Lighter Weight than competitive belt-drive and gear head operator models. A 1/2 HP MG weighs 42 lbs., half that of competing 1/2 HP belt drive and gear head operators.
- Motor Mounted Interlock available to 1/2 HP - unique feature with gear head operators.
- Auxiliary Chain automatically engages and disengages, just pull to operate.
- Auxiliary Chain can be easily added to or removed from operators in the field.
- UL Listed



## New Logic Technology

Cornell's MG series operators offers the following logic technology features as standard:

- Cycle Counter
- Connection module for a monitored entrapment protection device
- 24V DC close warning output signal
- On board Open/Close/Stop buttons

### Optional Features:

- Timer to Close
- Module for secondary monitored entrapment protection device

## MG Series Operators Standard Features

**Operator:** Design configuration is ideal for coiling door products. Industrial-duty, high starting torque with overload protection. Available in 1/3, 1/2 and 3/4 HP; single-phase capacitor start and three phase motors.

**Drive Reduction:** Lubricated, heavy-duty gears.

**Auto-Reset Thermal Protection:** Prevents motor burnout.

**Limit Switches:** Linear driven, fully adjustable screw type cams.

**Operator Safety Feature:** Activating "Open," "Stop" or a remote transmitter button will stop movement of a closing door.

**Pre-Wired for Sensing Edge / Sensing Devices:**

A sensing edge, photo eyes or other detection devices can be easily connected. Standard one second time delay prior to reversing prevents damage to door and operator.

**Auxiliary Chain Hoist:** Automatically engages and disengages as hand chain is operated. Cut off switch prevents motor operation when chain is in use.

**Removable Chain Hoist:** 4 screws to install or remove a chain hoist.

**Standard Exterior Radio Control Terminal:** Provides for easy and fast connection of radio controls.

**Brake:** Maintenance free, solenoid actuated brake - No adjustment required for the life of the operator.

**Bearings:** Heavy-duty bearings are used at all rotation points.

**Motor Mounted Interlock Option:** Unique feature with a gear-head operator. Available on 1/3 and 1/2 HP operators.

# CORNELL

**SAFE AND SECURE**

# Cornell Model MG Operators

## Model MG Operator Variations

Operator Code	MGR 33	MGH 33	MGR 50	MGH 50	MGR 75	MGH 75
Horsepower	1/3 hp	1/3 hp	1/2 hp	1/2 hp	3/4 hp	3/4 hp
Voltage	115V/230V 460V	115V/230V 460V	115V/230V 460V	115V/230V 460V	115V/230V 460V	115V/230V 460V
Phase	1 & 3	1 & 3	1 & 3	1 & 3	1 & 3	1 & 3
Frequency	60 Hz.	60 Hz.	60 Hz.	60 Hz.	60 Hz.	60 Hz.
Maximum Rated Duty	20 cycles/Hour	20 cycles/Hour	20 cycles/Hour	20 cycles/Hour	20 cycles/Hour	20 cycles/Hour
Drive Chain	#50	#50	#50	#50	#50	#50
Internal Lock Sensor	Optional (MGRL33)	Optional (MGHL33)	Optional (MGRL50)	Optional (MGHL50)	Not Available	Not Available
Auxiliary Hand Chain	Not Provided	Included	Not Provided	Included	Not Provided	Included

Above products are protected by patent #6,900,602, #11,446,561 and #7,055,283. Other patents pending.

## Mounting Options

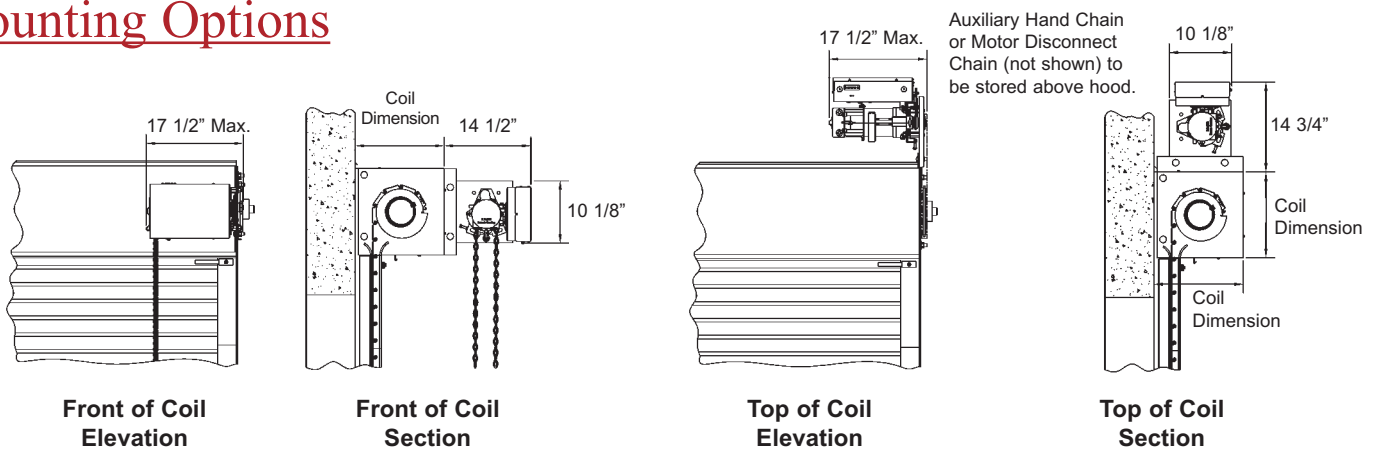

## Details and Clearances

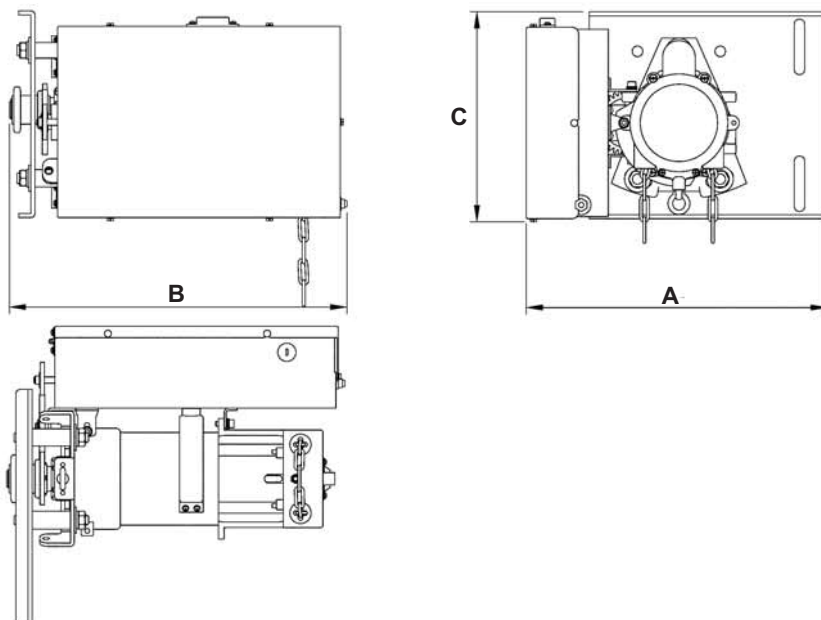

	MG Series		
	A	B	C
1/3 HP	14 1/2"	16 7/8"	10 1/8"
1/2 HP	14 1/2"	17 1/8"	10 1/8"
3/4 HP	14 1/2"	17 3/8"	10 1/8"

**CORNELL**  
SAFE AND SECURE

An ISO 9001:2008 Registered Company

Crestwood Industrial Park  
Mountaintop, PA 18707

TEL 800.233.8366 • FAX 800.526.0841

Architect & Design Support Services: Ext. 551

Email: ADS@cornelliron.com

Website: [www.cornelliron.com](http://www.cornelliron.com)