

CORNELL

SAFE AND SECURE

Cornell
100 Elmwood Ave.
Crestwood Industrial Park
Mountaintop, PA 18707
Tel 800.233.8366
Fax 800.526.0841
Email: cornell@cornelliron.com

OWNER'S MANUAL

MODEL

FIREGARD DC

EXTENDED PERFORMANCE RELEASE DEVICE

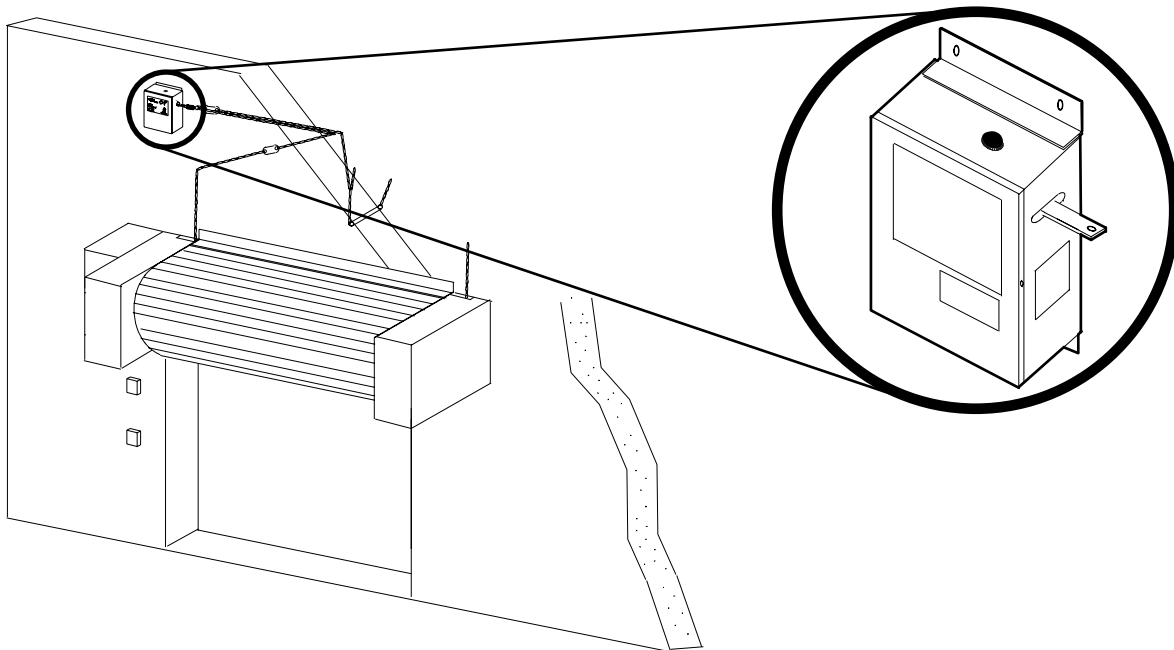

IMPORTANT : ADDENDUM TO INSTALLATION INSTRUCTIONS

Release Device without Battery Backup on Non-Motorized Door

OVERVIEW

The enclosed release device can receive alarm input from smoke detectors at terminals 3 and 4 or terminals 5 and 6 found on the logic board. Regardless of the alarm input, the release device requires specific placement of a 10k Ohm end-of-line resistor (LMEOLRES-10), a standard 10k Ohm resistor, and a wire jumper, which are included in the attached parts kit. These components must be taken from the parts kit and mounted as instructed below. Please follow these instructions and disregard text in the installation manual referring to these components as "factory installed."

NOTE: The following instructions show installation requirements that must occur when either terminals 3 and 4 or terminals 5 and 6 are not used.

For the alarm input at either set of terminals that is used, refer to the installation manual for proper wiring and the correct placement, when required, of the LMEOLRES-10 end-of-line resistor shown above.

INSTALLATION MANUAL SUPPLEMENTAL INFORMATION

Terminals 3 and 4 are used for a 2-wire detector initiation loop. If these inputs are not used, place the 10k Ohm resistor, included in the parts bag, between terminals 3 and 4 (Figure 1).

Terminals 5 and 6 are used for a normally closed initiation loop. If these inputs are not used, place the wire jumper, included in the parts bag, between terminals 5 and 6 (Figure 2).

WARNING

To avoid SERIOUS personal INJURY or DEATH, from electrocution, DISCONNECT electric power to operator BEFORE installing.

PARTS KIT

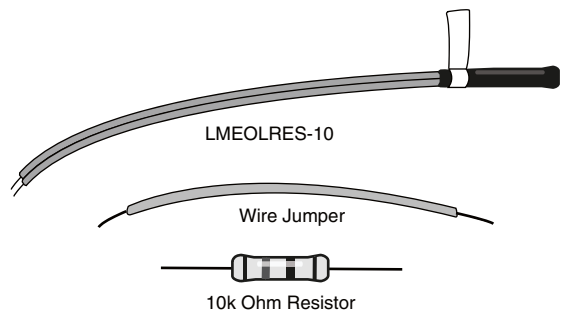

FIGURE 1

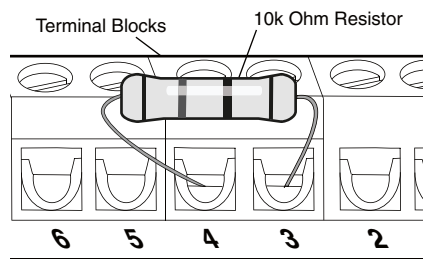
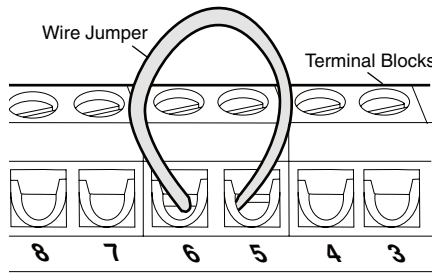

FIGURE 2



WIRING DIAGRAM

- Field Wiring shall consist of 22-18 AWG wiring
1. Supervised, power limited circuit, 20 Ohm maximum line impedance
 2. Unsupervised, power limited circuit, 20 Ohm maximum line impedance
 3. Maximum of 4 Class B Style A detectors
 4. Power from an approved UL1481 regulated supply with battery backup

2-Wire Detector Initiation Loop (1) (3)
Place 10k Ohm resistor between 3 & 4 if unused.

Resistor
10k Ohm EOL
(LMEOLRES-10)

Normally Closed Initiation Loop (1) (3)
Place wire jumper between 5 & 6 if unused.
External power required.

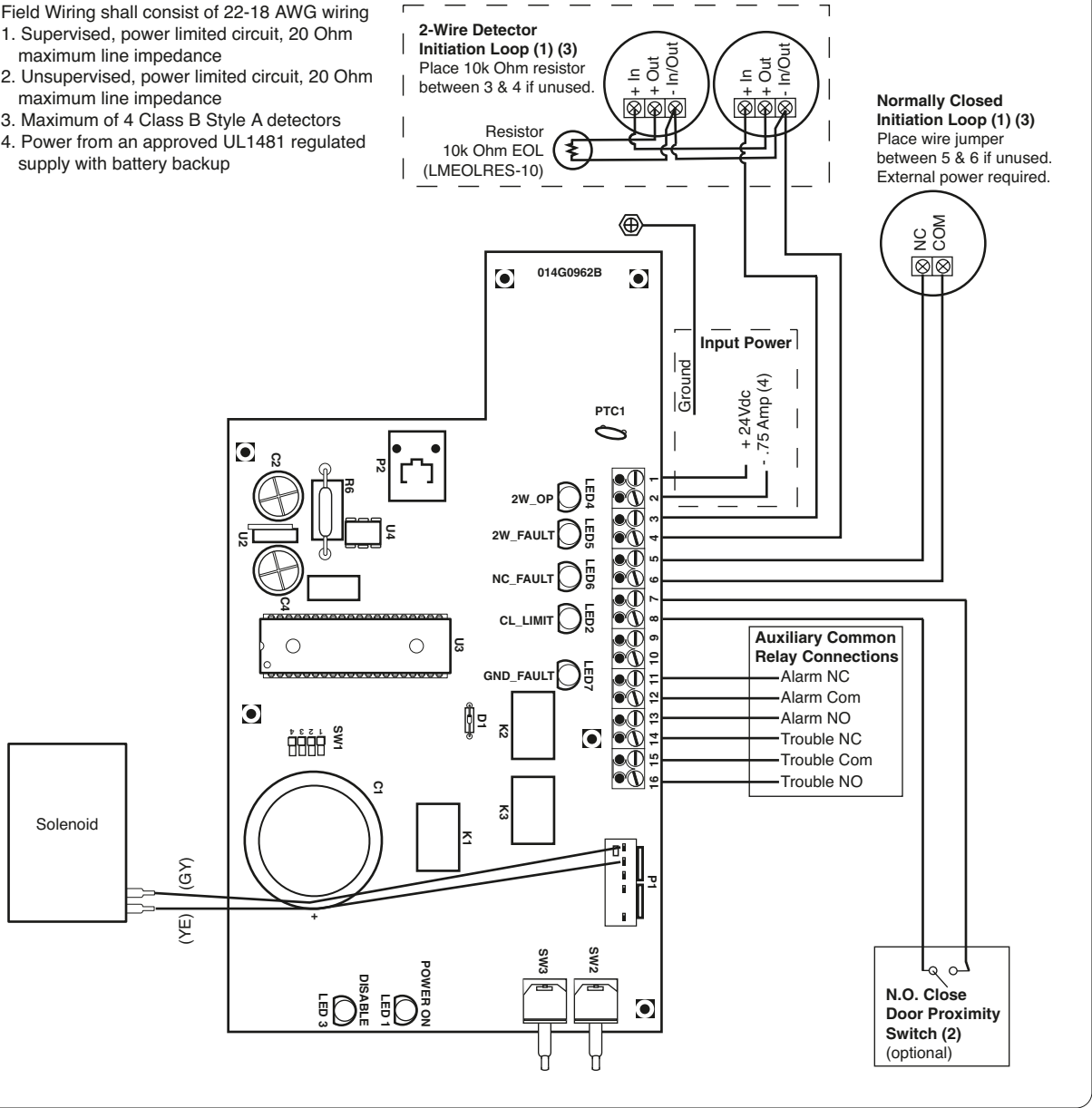

TABLE OF CONTENTS

INTRODUCTION

General Description	2
Agency Requirements	3
Specifications	3
Preparation	3

INSTALLATION

Important Installation Warnings	4
Mount the Release Device	4

WIRING

Wiring Instructions	5
Wiring Diagram	6
Connections of Initiating Devices and Accessories	7-8
Optional Connections	8-9

TESTING

Test Procedures	10
-----------------------	----

TROUBLESHOOTING

Operational Checklist	11
-----------------------------	----

MAINTENANCE

Maintenance Requirements	12
Enclosure Mounted LEDs Status Indicators	12

ACCESSORIES AND REPLACEMENT PARTS

APPENDIX

OPERATOR NOTES

WARNING

Mechanical

WARNING

Electrical

CAUTION

When you see these Safety Symbols and Signal Words on the following pages, they will alert you to the possibility of **serious injury** or **death** if you do not comply with the warnings that accompany them. The hazard may come from something mechanical or from electric shock. Read the warnings carefully.

When you see this Signal Word on the following pages, it will alert you to the possibility of damage to your door and/or the door operator if you do not comply with the cautionary statements that accompany it. Read them carefully.

IMPORTANT NOTES:

- *BEFORE attempting to install, operate or maintain the release device, you must read and fully understand this manual and follow all safety instructions.*
- *DO NOT attempt repair or service of your release device unless you are an Authorized Service Technician.*

INTRODUCTION

GENERAL DESCRIPTION

The FireGard DC Release Device is UL/ULC listed normally energized fail-safe device designed for use on rolling doors, single-slide and center-parting level and inclined track doors. All models are normally energized fail-safe releasing devices incorporating state-of-the-art electronic control circuitry. The release devices respond to emergency conditions generated from an automatic initiating device and are used in conjunction with a temperature fuse link system.

This device is designated to be used with manual doors, but can be used on motorized doors incorporating a fusible link assembly and drop-out mechanism.

The release device must be powered from 24Vdc received from an approved UL 1481 regulated power supply with battery backup. The devices can be activated via a smoke detector or an alarm relay from the panel's Form C dry contact relay. The release device features include a 10-, 20-, 30- or 60-second delay on alarm, closed door detection capabilities, Form C relay outputs for the transmission of alarm and trouble signals transmitted to the fire alarm control panel, an audible trouble sounder, and diagnostic feedback LEDs.

INTRODUCTION

AGENCY REQUIREMENTS

Installation and testing to factory specifications shall be performed by factory authorized personnel for proper operation in accordance with the latest National Fire Protection Association (NFPA), Underwriters Laboratories (UL), National Electrical Code (NEC), local, state, county, district and/or other applicable building and fire standards, guidelines, regulations and codes including, but not limited to, all appendices and amendments and the requirements of the local authority having jurisdiction (AHJ).

⚠ WARNING

To prevent possible SERIOUS INJURY or DEATH:

- DO NOT use this device without fuse links installed.
- Test every 90 days to assure proper operation of release device.

SPECIFICATIONS

ELECTRICAL SPECIFICATIONS

VOLTAGE RATING:	24Vdc
STANDBY CURRENT:	.100A
ALARM CURRENT:	.15A
INITIATING DEVICE:	Maximum line impedance 20 ohm; Maximum current not to exceed .010A.; Maximum voltage 28Vdc

COMMON ALARM AND TROUBLE RELAY:	.5A 125Vac, 60Hz
(MAX. CONTACT RATING)	1A 24Vdc Resistive

MECHANICAL SPECIFICATIONS

LOAD RATING:	Support and Release 40 lbs. Max.	WEIGHT:	Approximately 8 lbs.
PHYSICAL DIMENSIONS:	9.7" x 7.5" x 5" (h x w x d)		

PREPARATION

It is imperative that the wall or mounting surface provide adequate support for the release device.

Refer to the door manufacturer's recommendations for use of this product with specific door being utilized. Use only hardware approved or recognized by the appropriate testing and listing agencies in conjunction with the installation of this product.

Additional items may be required to complete the installation:

- Concrete anchors or fasteners
- Sash chain or 1/16 cable
- Eyebolts-hook
- Fuse links
- Turnbuckles
- Smoke detectors (up to 4 may be installed with this device)

Refer to NFPA 72 and NFPA 80 for instructions concerning proper placement and detection coverage. End-of-line devices shall be installed for supervision of electrical power to 4-wire smoke detector. When using 4-wire smoke detectors with this device, electrical supervision must be provided by means of a UL/ULC listed end-of-line relay.

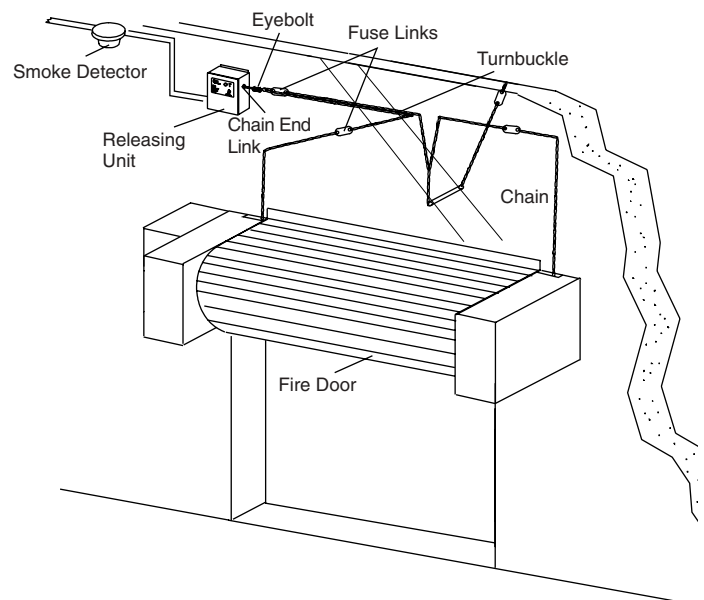

INSTALLATION

IMPORTANT INSTALLATION INSTRUCTIONS

WARNING

To reduce the risk of SEVERE INJURY or DEATH:

1. READ AND FOLLOW ALL INSTALLATION WARNINGS AND INSTRUCTIONS.
2. NEVER connect release device to power source until instructed to do so.
3. DO NOT install this device on a motorized door without an electric safety edge.
4. DO NOT use this device without fuse links installed.
5. Concrete anchors MUST be used if mounting release device into masonry.
6. DO NOT exceed maximum pull rating of 40 lbs. on releasing device.

Classification:

Releasing device as defined by Underwriters Laboratories.

Installation Requirements:

Intended for "Indoor Dry" locations; all wiring must be performed in accordance with the most current version of NFPA 72 - National Fire Alarm Code and the National Electric Code.

MOUNT THE RELEASE DEVICE

Installation procedures vary according to door types. Refer to door manufacturer's recommendation that applies to your door.

1. Mount the release device on a vertical surface with chain end link exiting side of enclosure.
2. Secure the release device enclosure with fasteners (#10 is the minimum size recommended). If installing in masonry, use concrete anchors (not provided).
3. Install hardware (sash chain or 1/16 cable, eyebolts-hook, fuse links, turnbuckles—not provided) according to door manufacturer's recommendations. **NOTE:** The end link direction of pull must be perpendicular to the side of the release device enclosure. Install an eyebolt a minimum distance of 12" from the release device to adequately redirect sash chain pull.
4. Install end link by pressing mechanical reset to allow insertion of end link. Push end link completely in and release mechanical reset to latch end link.
5. Remove sash chain or cable slack by adjusting turnbuckle.

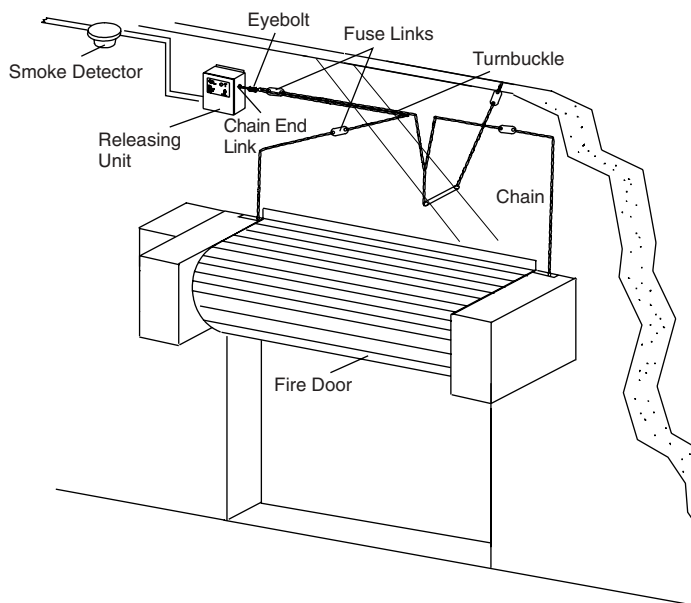
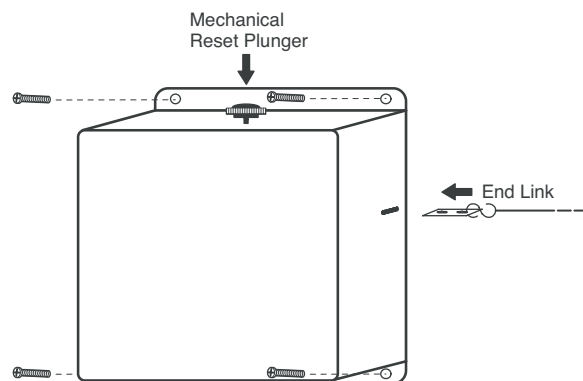

WIRING

WARNING

To reduce the risk of SEVERE INJURY or DEATH:

- ALL electrical connections MUST be made by a qualified individual.
 - Disconnect power at the fuse box BEFORE proceeding. Release device MUST be properly grounded and connected in accordance with local electrical codes.
 - ALL power wiring should be on a dedicated circuit and well protected. The location of the power disconnect should be visible and clearly labeled.
- ALL power and control wiring MUST be run in separate conduit.
 - Installation of ALL wiring and connections, including Class 1 and Class 2 circuits, shall be performed in accordance with, but not limited to, the latest NFPA, UL and N.E.C. standards and codes. In addition, ALL installations subject to Canadian standards shall be performed in accordance with the Canadian Electrical Code, Part I, with respect to wiring material type, wiring gauge related to power capacity requirements and circuit length and wiring methods.

WIRING INSTRUCTIONS

Verify wiring configuration with that recommended by door manufacturer for use of this product with specific door and accessories being utilized. 18-gauge wire is recommended.

1. Turn off power supply sources for the release device as well as the door operator, if applicable, before beginning.
2. Verify voltage rating of release device to power source being utilized. Voltage is indicated on the side of the unit. Verify that power is disconnected before proceeding.
3. Connect 24Vdc power to terminal board positions 1 and 2 (Figure 2). Observe proper polarity. 24Vdc power input from an approved UL 1481 regulated power supply with battery backup.

CAUTION

To prevent DAMAGE to the circuit board, ALL connections from terminals 3 through 16 MUST be dry contact type.

FIGURE 1

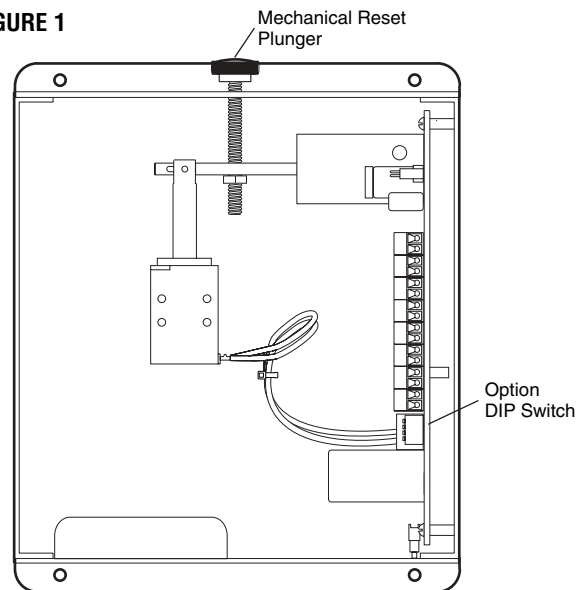
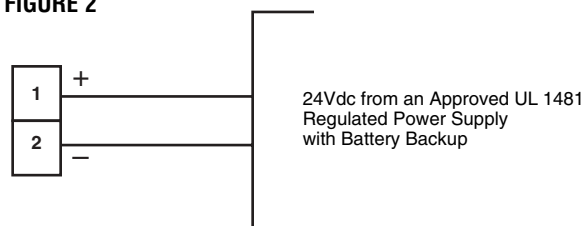

FIGURE 2



WIRING

WIRING DIAGRAM

Field Wiring shall consist of 22-18 AWG wiring.

1. Supervised, power limited circuit, 20 Ohm maximum line impedance.
2. Unsupervised, power limited circuit, 20 Ohm maximum line impedance.
3. Maximum of 4 Class B Style A detectors.
4. Power from an approved UL1481 regulated supply with battery backup.

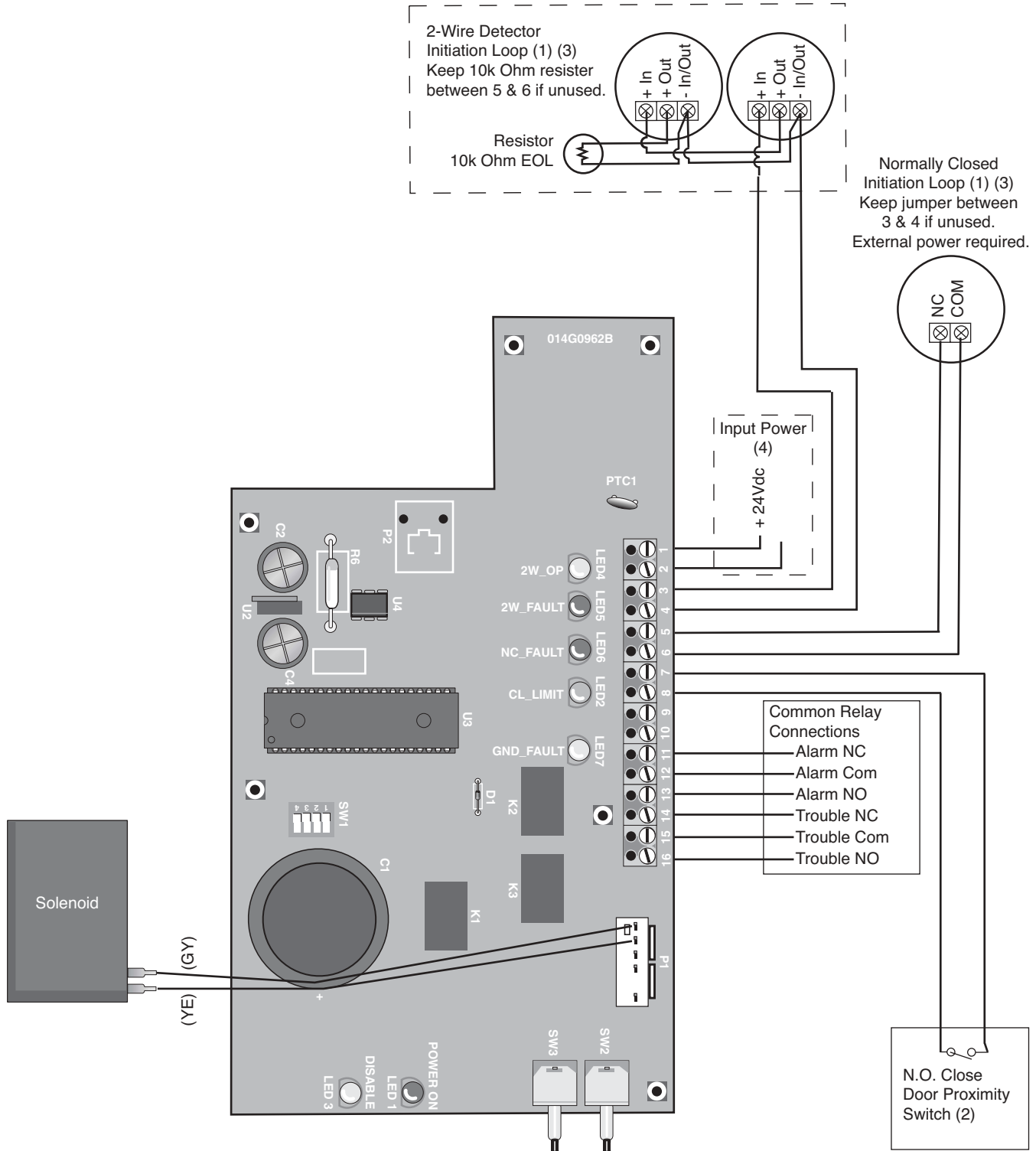

WIRING

CONNECTIONS OF INITIATING DEVICES AND ACCESSORIES

A maximum of 4 smoke detectors may be installed with this device. Refer to NFPA 72 and NFPA 80 for instructions concerning proper placement and detection coverage. End-of-line devices must be installed for supervision of electrical power to 4-wire smoke detector. When using 4-wire smoke detectors with this device, electrical supervision must be provided by means of a UL/ULC listed end-of-line relay.

NOTE: For low voltage wiring #18 AWG is recommended.

Normally Open "2-Wire," Class B Style A Initiating Devices

Connect wiring from N/O initiating device loop to positions 3 and 4. Place the supervisory resistor (10k ohm @ 1/2 watt) contained within the accessory pack. (Figure 3). Observe proper polarity, 3 (+), 4 (-) when attaching to the release device's terminal board.

NOTE: Make certain that the factory-installed jumper between terminal positions 5 and 6 remains in place. This option is a supervised, current-limited circuit.

OR

Normally Open "4-Wire," Class B Style A Initiating Devices

Connect wiring from N/O 4-Wire initiating device loop to positions 3 and 4, making sure an end-of-line supervisory resistor (10k ohm @ 1/2 watt) is installed as shown in Figure 4 or 5, depending upon the type of smoke detector being used. Observe proper polarity, 3 (+), 4 (-) when attaching to the release device's terminal board. **NOTE:** Make certain that the factory-installed jumper between terminal positions 5 and 6 remains in place. This option is a supervised, current-limited circuit.

OR

Normally Closed "4-Wire," Class B Style A Initiating Devices

After removing the factory-installed jumper between terminal positions 5 and 6, connect wiring from N/C 4-Wire initiating device loop to positions 5 and 6 (Figure 6). This option is a supervised, current-limited circuit. **NOTE:** Make certain that the factory-installed resistor between positions 3 and 4 remains in place.

NOTE: End-of-line devices must be installed adjacent and after the last initiating device. Initiating device loops are supervised and cannot be direct series or paralleled between multiple release devices or shared with other alarm equipment. For proper wiring configurations from multiple smoke detectors or signaling for simultaneous closure on multiple doors, call technical support, 1-800-233-8366. Incorrect wiring between devices may cause damage to the release control circuit and void warranty.

OR

Relay Module Installation as described on the following page.

⚠ WARNING

To prevent possible **SERIOUS INJURY** or **DEATH**:

- End-of-line devices **MUST** be installed for supervision of electrical power to 4-wire smoke detector.
- **DO NOT** install this device on a motorized door without an electric safety edge.

FIGURE 3

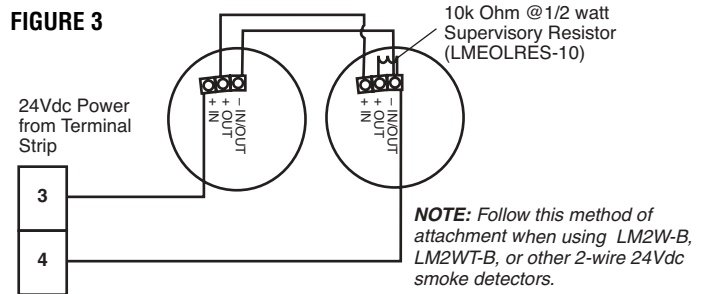

FIGURE 4 NOTE: Follow this method of attachment when using LM4W-B, LM4WT-B, or other N/O 4-wire smoke detectors.

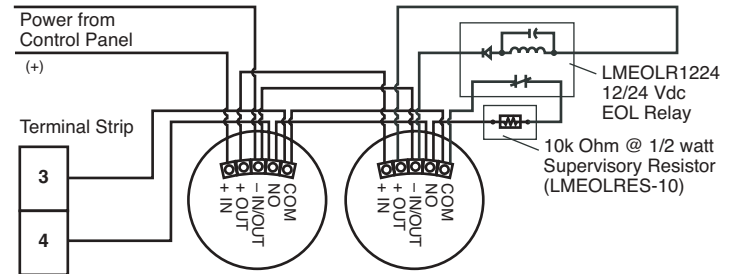

FIGURE 5 NOTE: Follow this method of attachment when using LM1424, LM1412, or other N/O 4-wire smoke detectors.

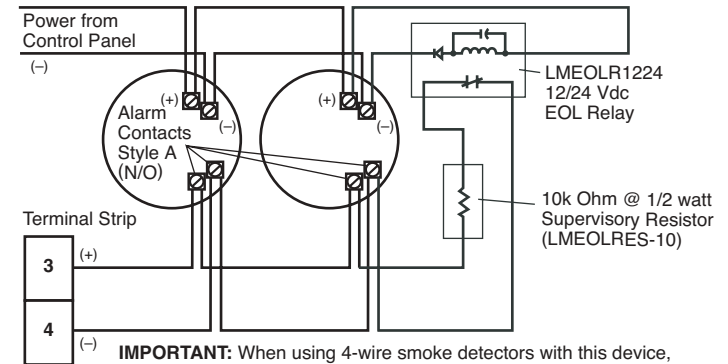
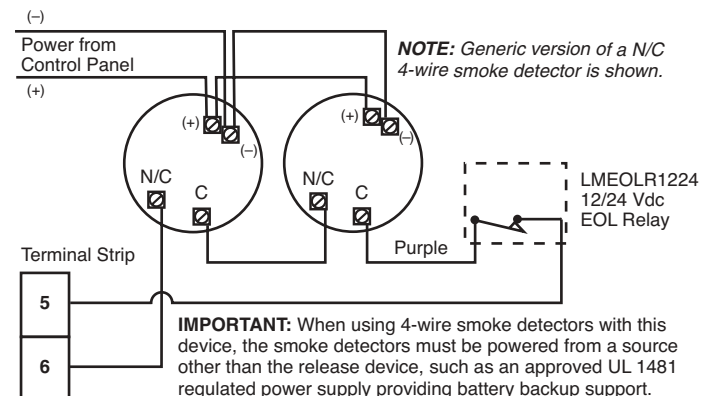

FIGURE 6



WIRING

CONNECTIONS OF INITIATING DEVICES AND ACCESSORIES (cont'd)

Relay Module Installation

In lieu of smoke detectors, the release device may be put into alarm by the fire alarm control panel. Most commonly, a relay module is used as an interface between the fire alarm control panel and the release device. The relay module must provide Form C dry contacts for connection to the appropriate terminals on the release device (Figure 7).

NOTE: When choosing a relay module to activate the release device in an alarm condition, always select one that provides Form C dry contact relays. Do not use any relay module providing or passing any (control) voltage through the contacts into the release device. The passage of voltage through such a relay module into the release device will cause problems with the operation of the device and may damage the device's terminals and/or circuit board.

OPTIONAL CONNECTIONS

CLOSE DOOR DETECTION OPTION

Connect wiring from N/O electrical loop, using a proximity switch or other similar device with dry contacts, to 7 and 8 (Figure 8). The switch should be placed to engage when the door is in the closed position and so that it will toggle states from its N/O condition (switch closed when door is closed) to a closed condition indicating that the door edge has made contact with desired down position. When the switch is closed by contact from the door, the release device will not activate on alarm, thereby eliminating nuisance gravity drops through the inadvertent release of the fusible link assembly. This option only works as long as power is available to unit. Fail-safe operation is maintained under all operating conditions, and if power is not available to the unit, the fusible link assembly will be released. This is a power-limited, unsupervised circuit. The proximity switch and the release device MUST be mounted in the same room.

RELAY AND TROUBLE OUTPUTS OPTION

Connect wiring from the Alarm Relay Outputs (#11 N/C or #13 N/O and #14 Common) to the appropriate inputs on the fire alarm control panel to provide a signal at the panel when the release device is in an alarm state. Connect wiring from the Trouble Relay Outputs (#14 N/C or #16 N/O and #15 Common) to the appropriate inputs on the fire alarm control panel to provide a signal at the panel that the release device is in a trouble state (Figure 9). If these features are desired, coordinate the interconnection between the Release Device and the Fire Alarm Control Panel with the fire alarm installer.

CAUTION

To prevent DAMAGE to the circuit board, ALL connections from terminals 3 through 16 MUST be dry contact type.

FIGURE 7

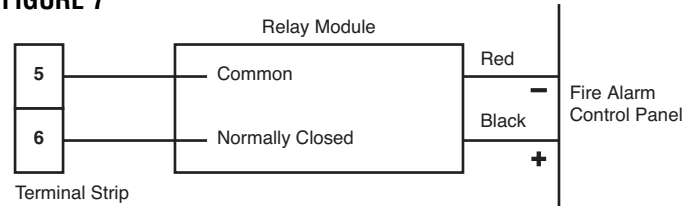

FIGURE 8

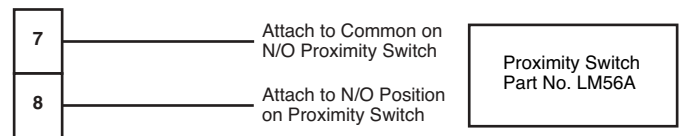
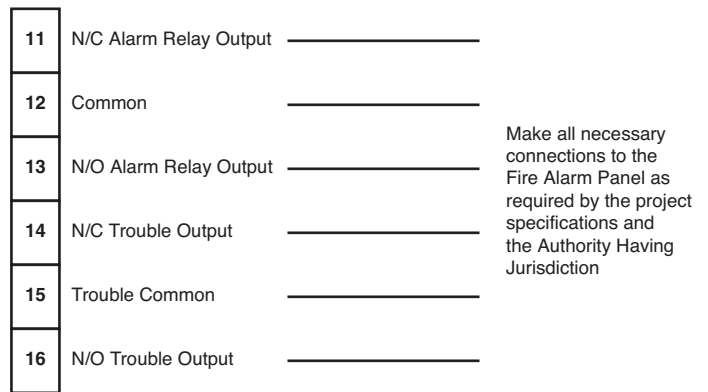

FIGURE 9



WIRING

OPTIONAL CONNECTIONS (cont'd)

DIP SWITCH SELECTION

The release device will provide a factory default delay of 10 seconds (to minimize nuisance alarms) before releasing the fusible link chain upon alarm or power loss. A 4-position DIP Switch found on the PC board within the release device can be used to adjust the length of the delay to one of four preset delays. The optional delay settings are as follows:

Delay Setting	Switch Position			
	1	2	3	4
10 Seconds	Off	Off	Off	Off
20 Seconds	Off	On	Off	Off
30 Seconds	On	Off	Off	Off
60 Seconds	On	On	Off	Off

NOTE: Set all DIP switch options before applying power to the system.

FIGURE 10

NOTE: Position 4 is unused and should remain in the OFF position. Position 3 is used to select one of the two available voice messages.

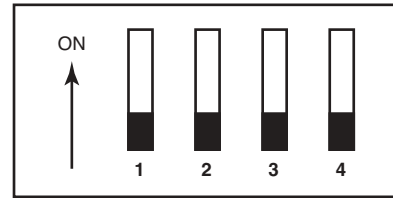

Factory default setting of 10 seconds shown.

TESTING

TEST PROCEDURES

TO BE PERFORMED BY FACTORY AUTHORIZED PERSONNEL ONLY! CLEAR FIRE DOOR OPENING AND PROHIBIT TRAFFIC THROUGH DOOR OPENING WHILE TESTING!

Testing does not affect normal operation of alarm system when connected to release device/control panel. Testing of the release device is independent of, and shall in no way be interpreted as an alternative method of, testing of a central fire alarm system, motorized operator and/or any other system component employed on the fire door or counter fire door installation. Complete testing and normal operation can only be accomplished with power applied to unit. Door must be in open position with power applied to unit to begin testing. The following procedures describe testing of all options. Verify options ordered and installed with unit. All tests may not apply. Refer to Figure 1 for location of all the LEDs and switches mentioned in this section.

INITIAL POWER UP

1. Apply line power to the release device.
2. Power LED (red) will be lit on the bottom of the release device.

MECHANICAL RELEASE

1. Depress and continue to hold test button on side of release device. After the selected delay expires, the device will release the end link and allow door to drop. Release test button.
2. Reset the door per door manufacturer's instructions. Raise door and then reset the release device by pushing downward on the mechanical reset button at the top of the device. Fully insert the end link through the side opening on the device and release the reset button in order to latch end link.

CLOSE DOOR DETECTION (OPTIONAL)

1. Using the chain hoist or motor operator, lower the door to fully closed position.
2. Verify that Close Door Detection LED (yellow) is lit indicating door closure. Depress and continue to hold test button on side of release device for 10 seconds. Close Door Detection logic will prohibit the release device from energizing and releasing the end link. Reset the test button.
3. Raise door to fully open position.

SUSPENSION OF POWER

1. Make sure door is in fully open position. Turn off all power to release device. Immediately upon loss of power to the release device, a mechanical release will be initiated.
2. Reset the door per door manufacturer's instructions. Raise the door and then reset the release device by pushing downward on the mechanical reset button at the top of the device. Fully insert the end link through the side opening on the device and release the reset button in order to latch end link. Press the "Reset" button on the side of the device to reset the alarm loop.

After completing all tests, make sure the door is in its normal condition (open or closed) and all power required for normal operation is restored to unit. The release device is designed to operate with power applied.

NOTE: Testing shall be performed and witnessed for proper operation.

⚠ WARNING

To prevent possible **SERIOUS INJURY** or **DEATH**:

- Clear fire door opening and prohibit ALL traffic through door opening while testing.
- Test every 90 days to assure proper operation of release device.

FIGURE 1

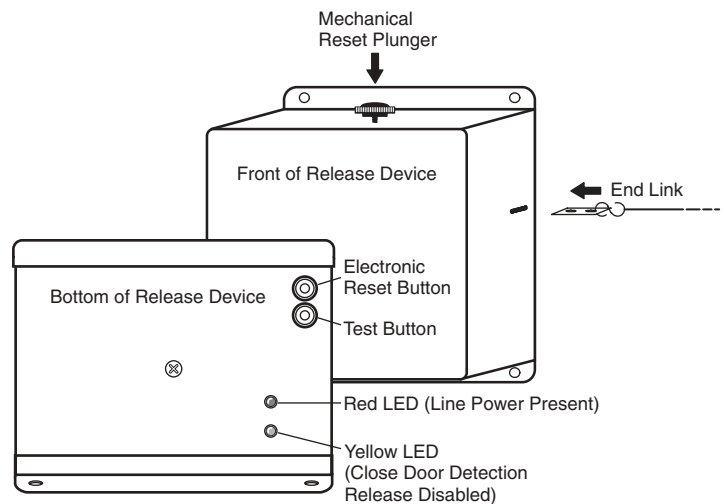

TROUBLESHOOTING

OPERATIONAL CHECKLIST

POWER

Is the red LED, labeled “Power,” located on the bottom of the enclosure lit?

Is the Red LED Lit?	
Yes	Move on.
No	Check power connections at terminal board positions 1 and 2.
	Check voltage; voltage should be 24Vdc received from an approved UL 1481 regulated power supply.

CHECK THE ALARM

Are the alarm (smoke detection) inputs correct? If not, the release device will not release the fusible link assembly in a fire condition. Conversely, the release device will always release the fusible link assembly when powered or reset.

Are the Alarm Inputs correct?	
Yes	Move on.
No	Check that it is a dry contact input. There should not be any voltage on the alarm lines when they are disconnected from the unit.
	Check to see if it is tied into an addressable relay module of an alarm panel. At times, noise can be picked up from these modules.

CIRCUIT BOARD DIAGNOSTIC LEDES

View diagnostic LEDs present on the circuit board located behind the terminal board. Refer to the table below for the status LED indications.

LED	LED Color	Description
N/O Detector Trouble	Yellow (LED 4)	If lit, indicates a trouble condition (a short) within the N/O 2-wire (or 4-wire) smoke detector loop (emanating from terminal board positions 3 and 4), resulting from either incorrect wiring or incorrect placement of the end-of-line resistor, and the smoke detector loop is inactive. Refer to the Smoke Detector Installation section on pages 7 and 8 of this manual for correct wiring instructions.
N/O Detector Alarm	Red (LED 5)	If lit, indicates that the N/O 2-wire (or 4-wire) smoke detector loop (emanating from terminal board positions 3 and 4) is in alarm. When lit during testing, press the Auxiliary Reset Button at the bottom of the release device to reset the loop.
N/C Detector Trouble	Red (LED 6)	If lit, indicates an open circuit within the N/C 4-wire smoke detector loop (emanating from terminal board positions 5 and 6), resulting from either incorrect wiring or incorrect placement of the end-of-line relay or the detector(s) are in alarm. If in alarm, cycle power off and then on to the smoke detectors to reset, then depress the auxiliary reset button to reset. Refer to the Smoke Detector Installation section on pages 7 and 8 of this manual for correct wiring instructions.
Close Door Detection	Green (LED 2)	If lit, indicates that the fire door or shutter is closed and activating the proximity switch. If not lit, refer to the Close Door Detection section of this manual for correct wiring instructions.
Ground Fault	Yellow (LED 7)	If lit, indicates that one of the ancillary devices/loops (smoke detector, annunciator, etc.) is not grounded properly, and a short to earth ground exists.

CHECK THE CLOSE DOOR DETECTION

Is the Yellow LED on the bottom of the enclosure lit? If lit, the close limit is active and the device is disabled and will not release the tension on the door spring as the door is in the closed position, activating the proximity switch. If not lit, check wiring instructions in Figure 8.

MAINTENANCE

MAINTENANCE REQUIREMENTS

The release device has no scheduled maintenance requirements. The unit has been designed and tested for use in dry, indoor locations. Testing of the unit at least once every 90 days is recommended, but test intervals shall ultimately be subject to criteria established by the Authority Having Jurisdiction (AHJ).

WARNING

To avoid **SERIOUS PERSONAL INJURY** or **DEATH** from electrocution, disconnect **ALL** power **BEFORE** performing **ANY** maintenance.

FIGURE 1

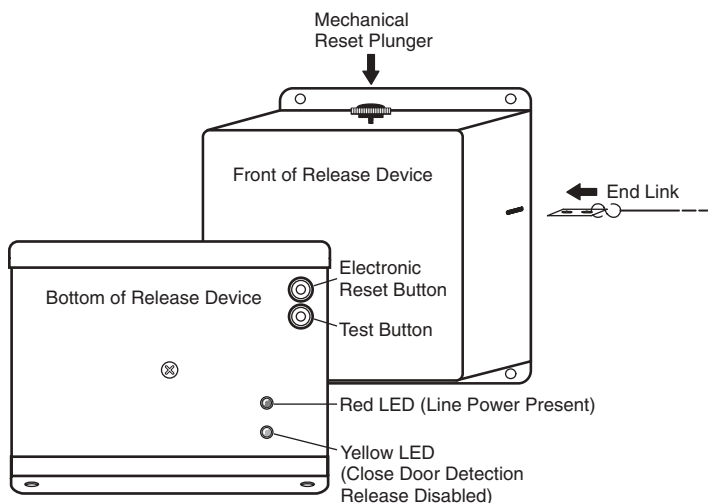

ENCLOSURE MOUNTED LEDS STATUS INDICATORS

LED Label	LED Color	Description	Action Required
Disable	Yellow	The Yellow LED will light when the door reaches the close limit and activates a proximity switch attached to terminal positions 7 and 8 on the release device. This configuration results in the device not releasing the fusible link assembly in alarm or power loss situations and should only be used when the fire door is kept in a constant closed position.	If the LED does not light when the door reaches the close limit and activates the proximity switch, then check that the proximity switch has been activated and that the switch is set to normally open (N.O.). Check to make certain that the switch is attached to terminal positions 7 and 8 on the release device.
Power	Red	If the Red LED is lit, then the line power is connected and switched "on."	If the LED does not light when power is applied, check that power is connected as described in the installation manual electrical connections.

ACCESSORIES AND REPLACEMENT PARTS

ACCESSORIES

ITEM	PART #	DESCRIPTION	ITEM	PART #	DESCRIPTION
1	LM8100	Smoke Detector - 120V Photo	7	LM4WT-B	Smoke Detector - 12/24Vdc 4-Wire Photo with Thermal and Form C Relay
2	LM8100T	Smoke Detector - 120V Photo with Thermal	8	LM1424	Smoke Detector - 24Vdc Ion
3	LM8100I	Smoke Detector - 120V Ion	9	LM1412	Smoke Detector - 12Vdc Ion
4	LM2W-B	Smoke Detector - 12/24Vdc 2-Wire Photo	10	LMTH135	Heat Detector - 135 Degree Fixed Temperature
5	LM2WT-B	Smoke Detector - 12/24Vdc 2-Wire Photo with Thermal	11	LMTH194	Heat Detector - 194 Degree Fixed Temperature
6	LM4W-B	Smoke Detector - 12/24Vdc 4-Wire Photo	12	LMEOLR1224	End-of-Line Relay - 12/24Vdc
			13	LMEOLR120	End-of-Line Relay - 120Vac

REPLACEMENT PARTS

ITEM	PART #	DESCRIPTION
1	LMRK	Reset Knob
2	LMELH	End Link
3	01-32046	Owner's Manual
4	LMEOLRES-10	End-of-Line Resistor, 10 kOhm

NOTE: Certain accessories above will require a separate power source. Refer to product manual.

HOW TO ORDER REPAIR PARTS

OUR LARGE SERVICE ORGANIZATION SPANS AMERICA

Installation and service information call:

(800) 233-8366

APPENDIX

ACCESSORY COMPATIBILITY GUIDE

SMOKE DETECTORS

MODEL NO.	DESCRIPTION	SYSTEM SENSOR MODEL NO.	
LM2W-B	24Vdc 2-Wire Photo	2W-B	
LM2WT-B	24Vdc 2-Wire Photo with Thermal	2WT-B	
LM4W-B	24Vdc 4-Wire Photo	4W-B	
LM4WT-B	24Vdc 4-Wire Photo with Thermal & Form C Relay	4WT-B	
LM1424	24Vdc Ion	#1424	

HEAT DETECTORS

MODEL NO.	DESCRIPTION	SYSTEM SENSOR MODEL NO.	CHEMTRONICS MODEL NO.	EDWARDS SYSTEM TECHNOLOGY (EST) MODEL NO.
LMTH135	135 Degree Fixed Temperature	#5603	#603	#283B-PL
LMTH194	194 Degree Fixed Temperature	#5604	#604	#284B-PL

END-OF-LINE DEVICE

MODEL NO.	DESCRIPTION	SYSTEM SENSOR MODEL NO.	SPACE AGE ELECTRONICS NO.	LIFTMASTER NO.
LMEOLRES-10	10 kOhm End-of-Line Resistor			LMEOLRES-10
LMEOLR1224	End-of-Line Relay	EOLR-1		
LMEOLR120	End-of-Line Relay		PAM-1	

NOTE: Certain accessories above will require a separate power source. Refer to product manual.

