

CrossingGard®

EMERGENCY RESPONSE GRILLE

Model ERG-IBC Access-Controlled Egress per the IBC®

The CrossingGard ERG (Emergency Response Grille) is designed to help address both the security and safety issues of public areas. The CrossingGard provides the security of a locked, rolling grille but immediately responds in an emergency situation to fully open automatically and allow safe escape. Available only from Cornell, the CrossingGard is always on duty to provide separation control, yet still allows for alternate means of escape should a fire, public disturbance or other emergency situation arise.

Practical Design Applications

- Corridor protection in any public building which limits functional space at different times or for special events, such as in:
 - schools
 - hospitals
 - office buildings
 - transportation terminals
- Separation control grille applications where emergency personnel will require immediate access to secured areas in a crisis situation
- Applications where combined ease of opening and security is desired.
- Openings that are part of a required means of egress



Benefits

- CrossingGard ERG-IBC is ICC-ES evaluated for access-controlled egress per the International Building Code®.
- No manual locking or unlocking required. AutoLock automatically secures a closed grille by engaging upon attempt of forced opening. AutoLock remains disengaged during normal and emergency operation.
- Fail-safe emergency response capability. When an alarm is sounded, power is lost or if the IBC emergency exit push-button station is activated, the CrossingGard immediately clears the path by returning the grille to its full open position without requiring an electric or battery power source.
- Following an emergency situation, the CrossingGard can be repositioned to the closed position by activating "close" at the motor control station. No operator resetting is necessary to resume normal operation.
- Operating mechanism can be recessed above the ceiling with no affect on operation.
- Rugged, open grille pattern construction provides durability and low maintenance.
- Convenient motor operation.
- Choice of finishes and guide trim package improve installation aesthetics.
- Cornell's 2 Year Quality Warranty.

CORNELL
SAFE AND SECURE

CrossingGard® Components



Brackets

Minimum 1/4" steel plates bolt to guide supporting member and support counter-balance shaft and curtain.

Standard Material & Finish: steel, with SpectraShield® powder coating Cornell gray

Counter-balance Shaft

4-1/2" minimum diameter outer shaft and 1-1/4" minimum inner shaft. This assembly supports the curtain and contains counter-balance torsion springs for fail-safe automatic opening of grille.

Standard Material: steel



Optional Hood, Fascia & Operator Cover

(not normally provided when unit is concealed above a ceiling) Protective sheet metal enclosures for the curtain and motor operating mechanism.

Standard Material & Finishes: galvanized steel with exclusive GalvaNex™ finish in light gray or aluminum in mill, clear and color anodized or 300 series stainless steel with a #4 finish



Motor

Cornell M100 FS series motor operator supplied as standard to provide fail-safe automatic emergency opening capabilities.

Guides

Extruded aluminum sections equipped with polypropylene pile runners, snap on trim and mounting member. Support the entire weight of the unit.

Standard Material & Finish: mill finish aluminum
Optional Finishes: clear and color anodized aluminum



Curtain

Open curtain pattern design with a series of solid 5/16" diameter horizontal rods at 2" spacing and vertical chain sets spaced at 9", 6" or 3" on center.

Standard Material & Finish: mill finish aluminum
Optional Materials: stainless steel rods and chains or galvanized steel rods



Bottom Bar

2" x 3 1/2" heavy duty extruded aluminum tubular section.

Standard Material & Finish: mill finish aluminum

Optional Material: stainless steel angles

Optional Component: bottom bar sensing edge



AutoLock Mechanism

Concealed self lock assemblies prevent forced opening of a closed grille. Lock mechanism will not interfere with normal electric, fail-safe or emergency response self opening feature.

Self-Supporting Installation Option

Many grille installations utilize structural tubes for support, which allows for installation prior to the walls and ceiling being built. The tubes are factory prepared for the attachment of all grille components. Tubes are attached to the floor slab below and the joists above, thereby becoming self-supporting.

Mounting & Clearances

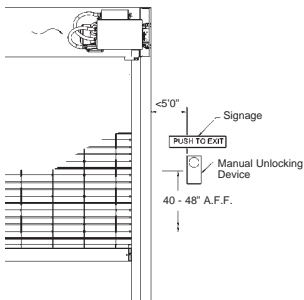

Model ERG-IBC

Mounting similar to standard with added signage and emergency exit push-button station

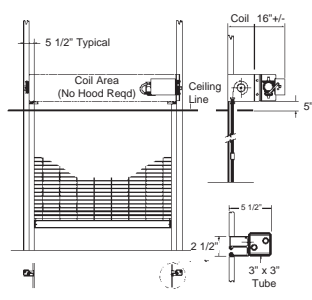

Between Jambs with Tubes

Structural tubes attach to floor and structure above or to structural side walls

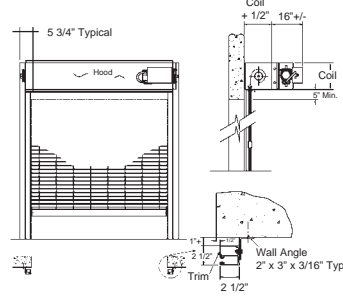

Face of Wall

Maintains clearance of full opening, minimal exposed components.

CrossingGard®

Security of an open curtain pattern rolling grille combined with a fail-safe operator to provide automatic emergency opening capabilities.

Operation

- Standard control station allows normal run and hold electric motor operation.
- Counter-balance shaft is designed with constant open spring torque.
- On alarm, power failure or emergency exit push-button station activation, the grille runs to the open position without the use of electric power or a battery power source.
- Controlled automatic or emergency opening speed of between six and nine inches per second.
- Once the alarm is cleared and/or power is restored and the push-button station is reset the grille is ready for normal electric operation.

Locking

- Unique automatic locking mechanism provides an added level of security by preventing lifting of a closed grille.
- AutoLock mechanism engages upon unauthorized forced opening, but remains disengaged during normal and emergency operation.

Standard Features

- Cornell M100 FS series electric motor operator
- Cornell AutoLock assembly
- Rugged, commercial duty, open grille pattern construction
- Designed for up to 20 operating cycles per day
- Built to opening sizes up to 24' wide and 20' high
- Guide trim package provided
- Includes signage and emergency exit push-button station

Optional Equipment

- Annunciator - preannounces grille opening in response to signal from the fire alarm system
- Sensing Edge - enables closing grille to stop upon encountering an obstruction

Curtain Designs & Finishes

- Open curtain grille pattern construction with 9", 6" or 3" vertical chain link spacing and 2" horizontal rod spacing (stainless steel vertical chain links only available with 2" spacing).
- Curtain rods available in aluminum, galvanized or stainless steel material.
- Curtain chain sets available in aluminum or stainless steel material.
- Aluminum available with standard mill finish or in clear, medium bronze, dark bronze or black anodized.

CORNELL

SAFE AND SECURE

An ISO 9001: 2000 Registered Company

Crestwood Industrial Park
Mountaintop, PA 18707

TEL 800.233.8366 • FAX 800.526.0841

Architect & Design Support: Ext. 551

Website: www.cornelliron.com

Email: ADS@cornelliron.com

CrossingGard Grilles are built to order to fit openings from 5' to 24' wide and from 4' to 20' high.

