



MANUAL RESET ALARM RELEASE BOX

FireGard™ AR-D

(For 115 or 24VAC or 24VDC)

INSTRUCTION MANUAL

WARNING

1. **CAUTION:** Review all installation instructions, procedures, cautions and warnings contained within this manual prior to installing and/or servicing this product. As with all releasing device systems, maximum fire protection is provided when installed in accordance with factory specifications and used with fuse link systems.
2. **DO NOT** install this unit without fuse links.
3. Installation and testing to factory specifications shall be performed by factory authorized personnel for proper operation in accordance with all of the latest National fire Protection Association (NFPA), Underwriters Laboratories (UL), National electrical Code (NEC), local, state, county, district and/or other applicable building and fire standards, guidelines, regulations and codes including, but not limited to, all appendices and amendments and the requirements of the local authority having jurisdiction (AHJ).
4. To be performed by factory authorized personnel only.
5. Clear fire door opening and prohibit all traffic through door opening during testing of system!

Installation Tip: Try out this unit before installing onto a fire door system. Test and learn the release mechanism before connecting to a fire door.

INTRODUCTION

The releasing device is a failsafe constantly energized solenoid mechanism. It is designed for use on rolling doors, single-slide and center-parting level and inclined track doors. Inside the mechanism, contact relays receive the alarm signal from the fire alarm control panel. When the unit receives the signal, the power to the solenoid is cut, releasing the fire door mechanism and hence close the fire door. The alarm signal can be Form C dry contact or 24VDC/VAC. Any interruption of power will release the solenoid mechanism. The release has a 10 second delay upon power failure and alarm, closed door detection capabilities, Form C relay outputs for the status of release box and 24VDC power output for door close warning.

SPECIFICATION

Input Power*:	115VAC, 0.5A; 24VAC, 0.5A; 24VDC, 0.2A
Alarm Dry Contact Rating:	24VDC, 0.08A, 5.16 ohms max line impedance
Lower Limit Microswitch Rating:	30VDC, 0.08A, 5.16 ohms max line impedance
Door Close Warning Power:	24VDC @Max. 0.23A, Resistive, Special Application (see below)
Status Dry Contact:	Rating: 30VDC/VAC, 2A, Resistive Load
Frequency:	50Hz or 60Hz
Release Pull:	50 lbs (22.7kgs)
Fuses:	F1: 4A@250V, Fast-Act Type F2: 3A@250V, Slo-Blo Type

*Input voltage [standby/full load**/start current]: 115VAC [0.5/0.6/1.1A], 24VAC [0.5/0.8/1.8A] or 24VDC [0.2/0.4/1.8A].

**Full load current only required for optional warning device(s).

- Must install with UL approved fusible links.
- 24V input power can be 24VDC or 24VAC or 24VDC from an approved UL1481 regulated power supply.
- 18-gauge wire recommended.
- For “Indoor Dry” location use only.
- Close warning power is provided for less than a minute. Any fire Listed audible or visual device may be used if the 24VDC input is powered by a UL1481 regulated power supply. When input power is 115VAC or 24VAC, please connect the following compatible devices: Bridgeport Fitting Inc Series 840P & 840T and Federal Signal Corp Model LP6 and Series LP3.
- **Note: Door Close Warning Output is only functional when the box has input power.**

INSTALLATION



Disconnect power supply before servicing.

- For “Indoor Dry” location use only. All wiring must satisfy the most current version of NFPA72 – National Fire Alarm Code and the National Electric Code.
- 18-gauge wire is recommended

INSTRUCTION & DRAWING

1. Actual configuration may differ. Must pull straight cable minimum 18 inches before turning (This unit may be rotated 90 degrees CW for a vertical pull.). See door manufacturer recommendations and NFPA 80 for use of this product with specific door. **DO NOT** install this unit without fusible links.
2. To be performed by factory authorized personnel only.
3. The release device shall be mounted on a vertical surface with chain end link exiting side of enclosure as illustrated on figure 1. The unit may be rotated 90 degrees CW for a direct vertical pull.

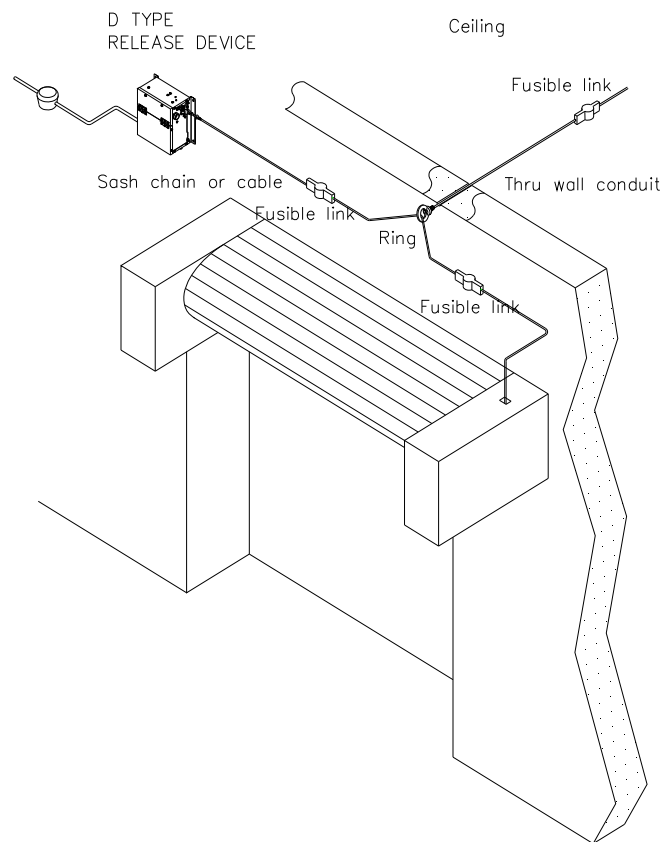

Figure 1

4. Release device and associated hardware [sash chain or 1/16 cable, eyebolts, fusible links (DO NOT install this unit without fusible links), turnbuckles] shall be installed as per door manufacturers recommendations (figure 1 typical installation configuration). Note should be taken that the end link direction of pull is perpendicular to the enclosure side. An eyebolt installed at a distance of 18 to 24 inches from the release device should adequately redirect sash chain pull as illustrated in figure 1. Please also see figure 2 for illustration.

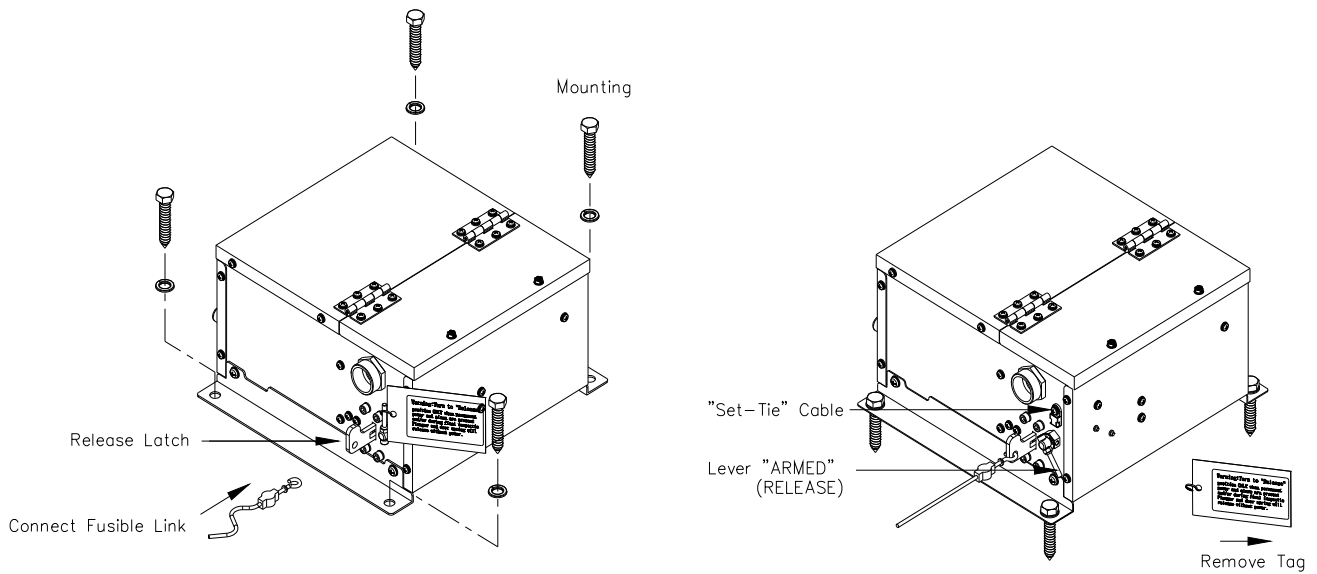

Figure 2



Disconnect power supply before servicing.

5. ELECTRICAL CONNECTIONS

Installation of all wiring and connections shall be performed in accordance with, but not limited to, the latest NFPA, U.L. and N.E.C. standards. In addition, all installations subject to Canadian standards shall be performed in accordance with the Canadian Electrical Code, Part I, with respect to wiring material, wiring gauge related to power capacity requirements and circuit length and wiring methods.

6. Verify voltage rating of release device to power source being utilized.
7. Connect fusible link and fire door system to release box.
8. Connect power and alarm connection to the unit.
9. Remove the “Set-Tie” cable after power and alarm connection.

“Set-Tie” cable mechanically secures release latch and must be removed to allow proper emergency operation of release device after installation is completed.

NOTE: A trouble sounder will be activated if power is present, the latch is engaged, but the “Set-Tie” has not been removed and/or the lever is in the “DIS-ARMED” position.

WIRING



Disconnect power supply before servicing.

WIRE ROUTING

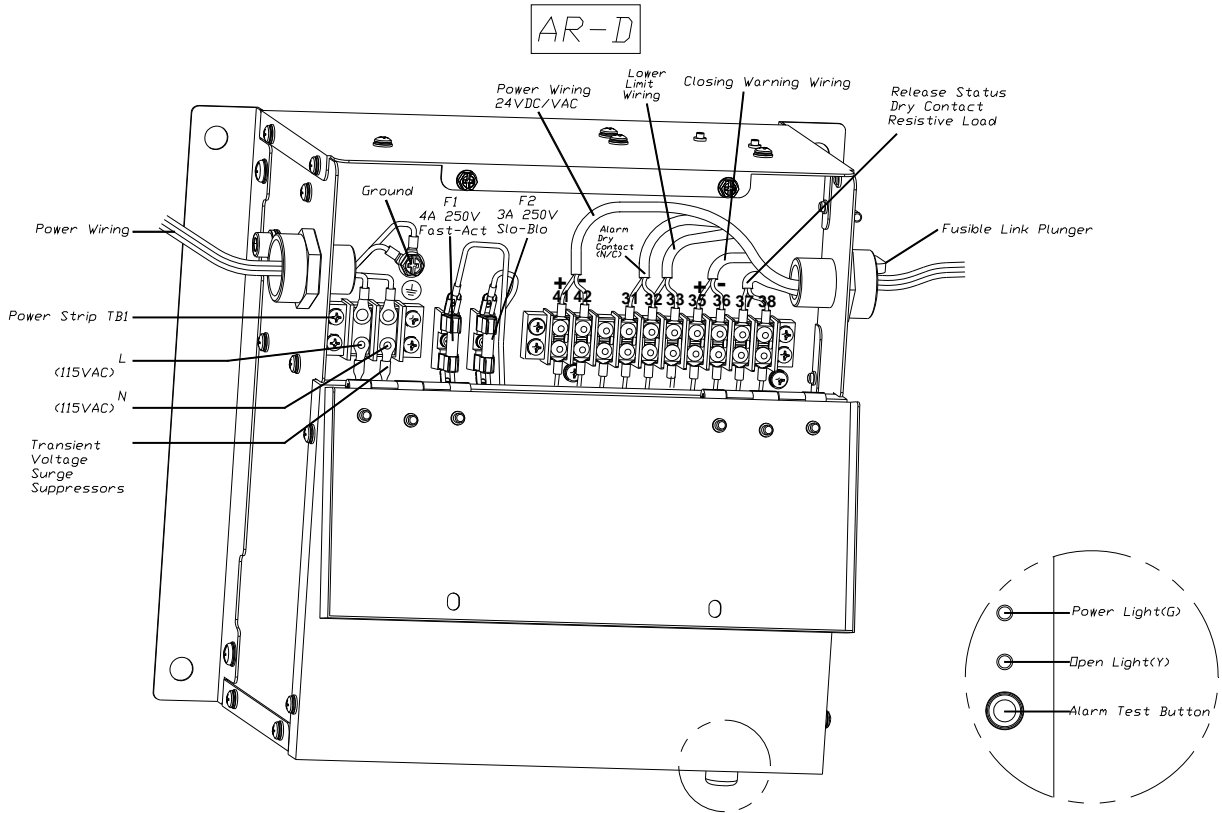

Note: Not supervised.

TERMINAL CONNECTIONS



Disconnect power supply before servicing.

TB1

L	N
Input power 115VAC*	

See **Note. 5**

TB2

41 (+)	42 (-)	31	32	33	35 (+)	36 (-)	37	38
Input 24VDC/VAC *Note. 5		Alarm Dry Contact (N/C) *Note 1			Door close warning 24VDC, total 0.23A *Note 3		Status dry contact *Note 4 30VDC/VAC 2A 16AWG 37.9ft Resistive load	
			Lower Limit Microswitch (N/C) *Note 2					

*** Note:**

1. Terminal 31&32

Building fire alarm panel needs to provide dry contact (N/C) connection with minimum capacity of 24VDC and 0.08 amp. To have 5.16 ohms max line impedance.

2. Terminal 32&33

Use this connection to notify release device the status of the door. Field installation of microswitch on the door is necessary to use terminal 32&33.

When the door is already in its close position, a closed contact (N/C) can cause the release device not to release (5.16 ohms max line impedance). Power failure will still cause the solenoid to let go, hence resetting is necessary.

3. Terminal 35&36

This connection provides 24VDC, 0.23A power with 18AWG wire for maximum of 20 ft., when release device has been released.

This can be used to provide power for warning devices. The warning power is provide for less than a minute. The wiring connections are enclosed within conduit or equivalently protected against mechanical injury.

4. Terminal 37&38

These terminal connections will provide the status of this release device. When release device is in the standby mode, connection is open (N/O). When release device have been activated or released, connection would be in closed (N/C) state.

5. See connection chart for power inputs.

Connection Chart

AR-D Terminals Connection Type	Line In High Voltage L & N	Low Voltage 41 & 42 (24VDC or 24VAC)	Alarm Connection 31&32
Power Input	Connect 115VAC	Connect 24VDC or 24VAC (Voltage supplied by FACP or an UL listed power supply)	Connect FACP* Alarm Dry Contact (5.16 ohms max line impedance)
High Voltage Alarm Signal	Connect Alarm Signal 115VAC	Do Not Connect	Jump (Wire size min 18AWG)
Low Voltage Alarm Signal	Do Not Connect	Connect Alarm Signal 24VDC or 24VAC (Voltage supplied by FACP)	Jump (Wire size min 18AWG)

* Note: FACP – Fire Alarm Control Panel.

WIRING DIAGRAM

RELEASE BOX D-TYPE(115V 1Ø or 24VAC/VDC)

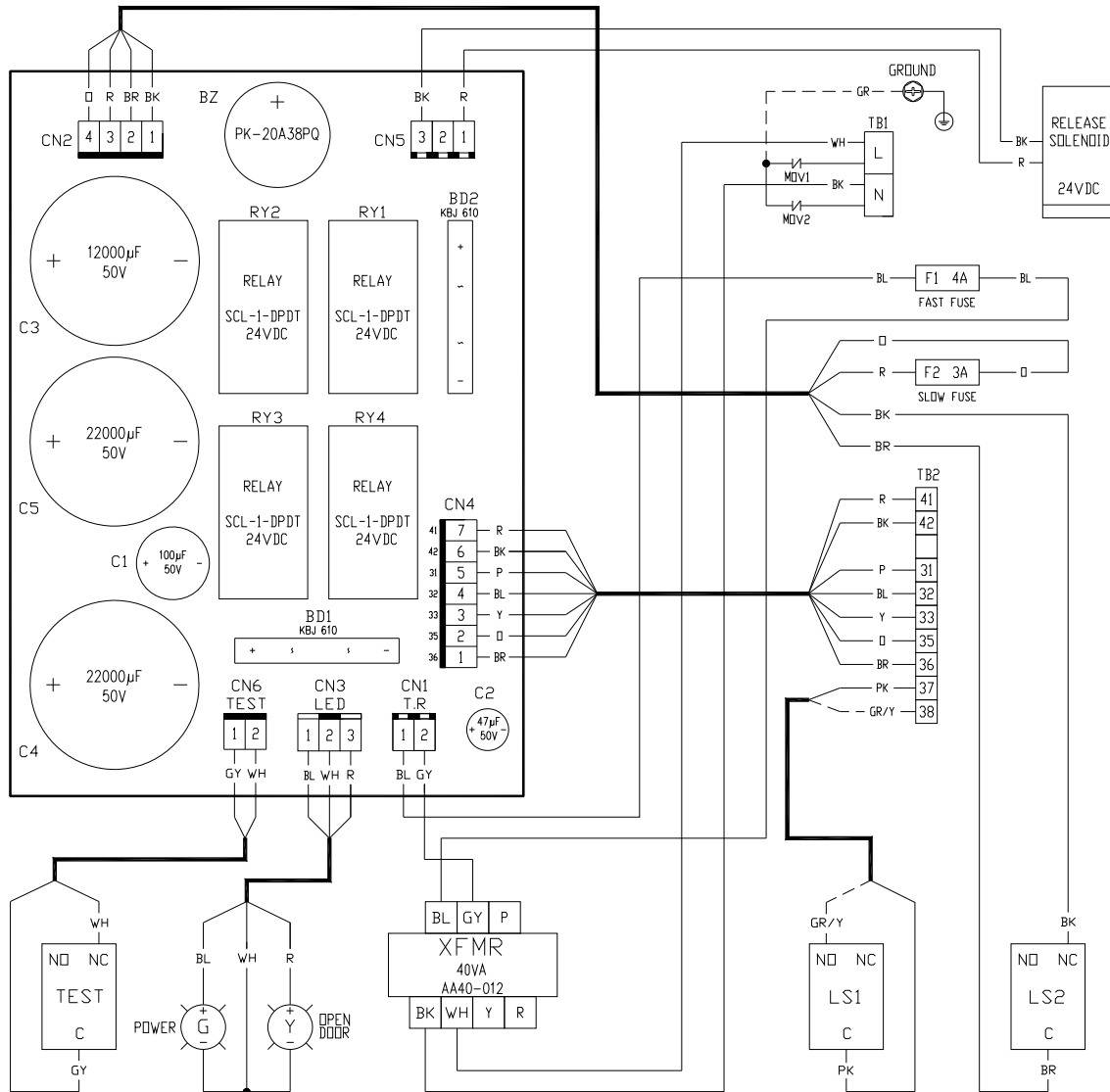

AR-D 115-6

NOTES:

1. TB1-TERMINAL L & N INPUT 115VAC
2. TB2-TERMINAL:
 41 & 42 INPUT 24VAC/VDC
 31 & 32 ALARM DRY CONTACT
 32 & 33 LOWER LIMIT MICROSWITCH
 35 & 36 DOOR CLOSING WARNING (24VDC,TOTAL 0.23A)
 37 & 38 RELEASE DRY CONTACT
3. LS1 - RELEASE SIGNAL DRY CONTACT N/D
4. LS2 - RELEASE HANDLE MICROSWITCH
5. TEST - ALARM RELEASE TEST BUTTON
6. DOOR - DOOR OPEN LIGHT (24VDC)
7. POWER - POWER LIGHT (24VDC)
8. MOV1 & 2 - TRANSIENT VOLTAGE SURGE SUPPRESSORS

2010.03.02

SCHEMATIC

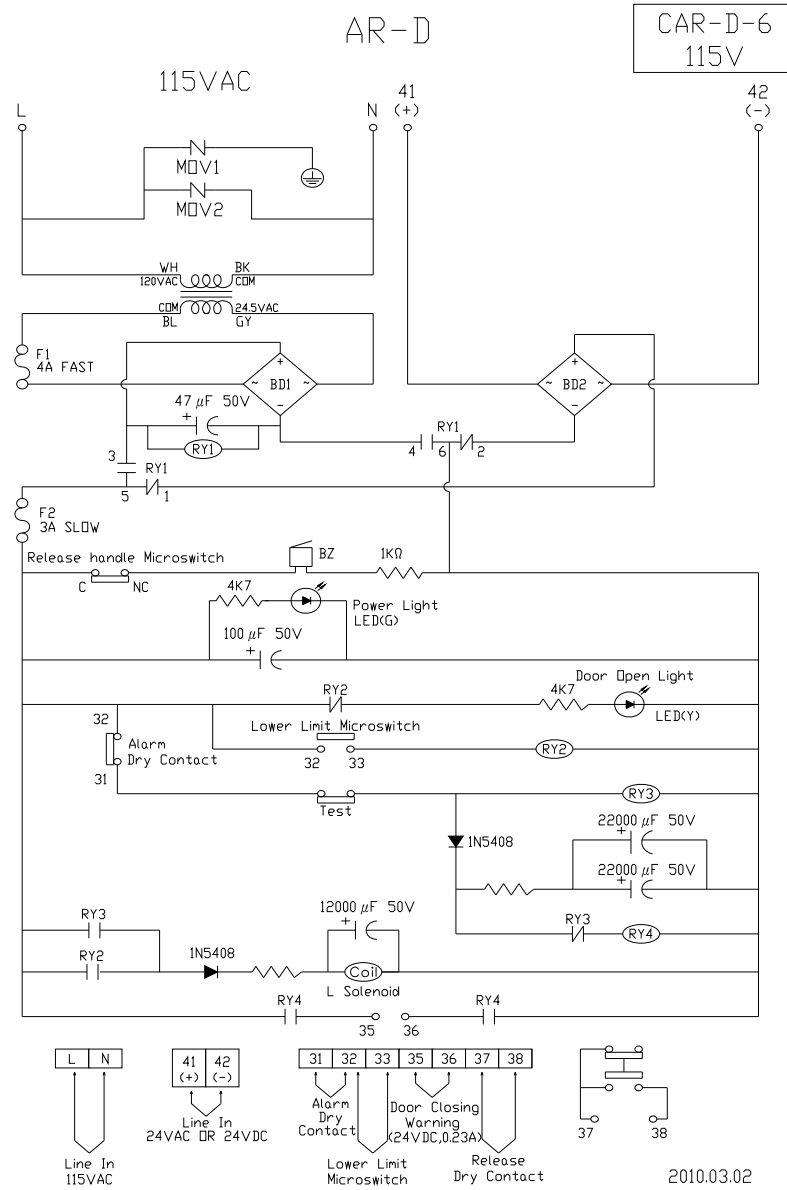

TESTING

1. Simulate an alarm condition and see if the solenoid disengages and releases the fire door.
2. Simulate a power failure and see if the solenoid disengages and releases the fire door.

RESETTING

1. Make sure power and alarm connection is normal.
2. Push the release latch all the way back into the slot.
3. Verify the solenoid is holding.
4. Connect fusible links to the fire door system.

Note: If the power or the alarm is not normal, solenoid will not hold. Hence the release latch will not stay in the slot.

MAINTENANCE INSTRUCTIONS



Disconnect power supply before servicing.

Check the following items at the intervals listed:

CHECK LIST	DESCRIPTION	EVERY 3 MONTHS	EVERY 6 MONTHS	EVERY 12 MONTHS
Fasteners	Check & tighten as required		●	
Drop-test	Inspect door, drop-test for proper operation and full closure per NFPA-80			●

- ❖ Inspect and service whenever a malfunction either door or release device is observed or suspected.
- ❖ Before servicing, always disconnect power supply to the release device.
- ❖ Replace fuses only with those of the same type and rating.
- ❖ All replacement parts must be obtained from the door manufacturer per NFPA-80.

Testing of the “AR” release device is independent of, and shall in no way be interpreted as an alternative method of, testing of the fire alarm system, and/or any other system component employed on the fire door or counter fire door installation. TESTING SHALL BE PERFORMED AND WITNESSED FOR PROPER OPERATION.