



INSTALLATION INSTRUCTIONS

AND

OPERATION MANUAL

SGH 50043E (Dual Operators)
(Front Hoist)

UL325-2010 Compliant
Commercial and Industrial Door Operator

Logic Control

Continuous Duty

IMPORTANT INSTALLATION INSTRUCTIONS

WARNING – To reduce the risk of severe injury or death to persons:

1. READ AND FOLLOW ALL INSTALLATION INSTRUCTIONS.
2. Install only on a properly operating and balanced door. A door that is operating improperly could cause severe injury. Have qualified service personnel make repairs to cables, spring assemblies, and other hardware before installing the operator.
3. Remove all pull ropes and remove, or make inoperative, all locks (unless mechanically and/or electrically interlocked to the power unit) that are connected to the door before installing the operator.
4. Install the door operator at least 8 feet or more above the floor if the operator has exposed moving parts. If the operator must be mounted less 8 ft (2.44 m) above the floor, then exposed moving parts must be protected by covers or guarding. Contact the manufacturer.
5. Do not connect the door operator to the source of power until instructed to do so.
6. Locate the control station: (a) within sight of the door, and (b) at a minimum height of 5 feet above floors, landings, steps, or any other adjacent walking surface and (c) away from all moving parts of the door.
7. Install the Entrapment Warning Placard next to the control station in a prominent location.
8. Make sure the available power supply to be connected to the operator is of the same voltage, frequency, phase and wattage as indicated on the nameplate of the operator.
9. Read and understand the wiring diagram of the operator and the control station (open-close-stop push button), and any other equipment to be connected to the operator.
10. To avoid damage to the door and operator, make all door locks inoperative. Secure locks in the unlocked position, or install external electrical interlocks to prevent operation with the locks engaged.
11. Always disconnect power whenever installing or servicing the door operator or door.
12. All wiring must be permanent and comply with National Electrical Code (NEC) and local code requirements.
13. Any change in mounting position may result in a change of operator rotation and consequently in a change of control functions. Consult factory for any changes.
14. If the operator is provided with an auxiliary chain operator, the hand chain should be kept inside the chain bag when operating electrically.
15. For products having a manual release, instruct the end user on the operation of the manual release.

SPECIFICATIONS

MOTOR	
Duty Cycle:	Continuous duty
Rating:	1000 ft.lbs./sec. per unit x 2
Speed:	1700 RPM
Voltage:	460 – 3 phase
Current:	See motor nameplate
ELECTRICAL	
Transformer:	24VAC
Wiring Type:	Momentary pressure open, stop, constant pressure close (provided standard), with provision for momentary pressure close*
Limit Adjustment:	Linear driven, fully adjustable screw type cams.
MECHANICAL	
Drive Reduction:	81:1
Output Shaft Speed:	21 RPM
Door Speed:	6”~8” per sec. average
Brake:	Solenoid actuated brake
Auxiliary Chain Hoist:	Standard
ENTRAPMENT PROTECTION	
Sensing Edge*:	(Optional) Sensing device attached to the bottom edge of the door.
Non-Contact Device*:	(Optional) Photo eye device.
* Per the requirements of UL Standard 325, the door operator is setup for constant pressure to close the door. As an alternative, the door may be provided with a monitored entrapment protection device that will reverse the door upon contact with or detection of an obstruction during closing. Adding an entrapment device would enable momentary close operation.	

***Note:**

1. Non-contact device (photo eye) can be used on doors up to 45 ft. wide (or maximum rated range of device if less than 45 ft.). Use a sensing edge to provide entrapment protection on doors over 45 ft. wide.
2. Sensing edge can be used on all doors.

TYPES AND SIZES OF DOORS

Consult factory for details.

INSTALLATION INSTRUCTIONS

INSTALLATION POSITION

Slave Operator

LS

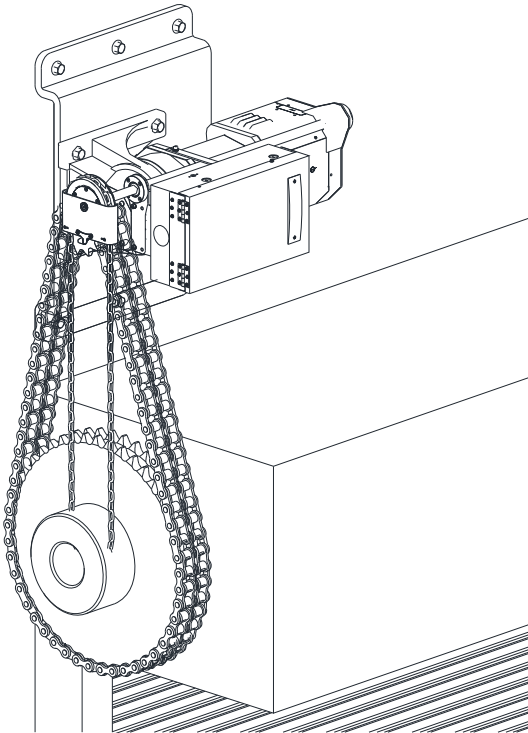

Master Operator

RS

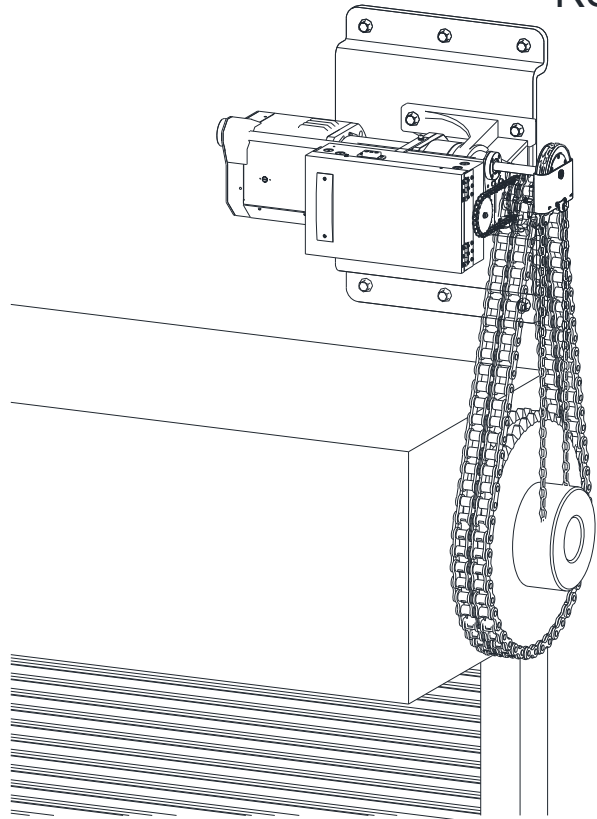

Consult factory for changes in installation positions.

NOTE: Any change in mounting position may result in a change of operator rotation and consequently in a change of control functions. Consult factory for any changes.

OPERATOR MOUNTING

1. Before the operator is installed, verify that the door is properly operating and balanced.
2. Make sure the layout of the mounting holes on the bracket are correct.

Slave Operator

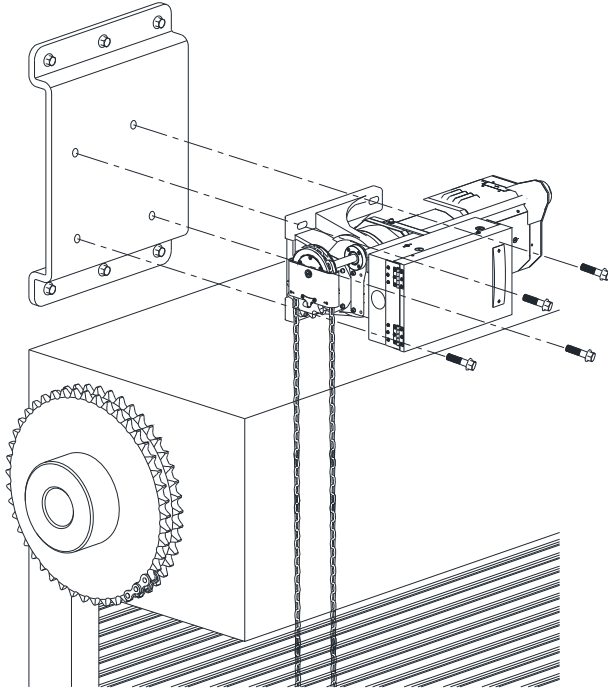

Master Operator

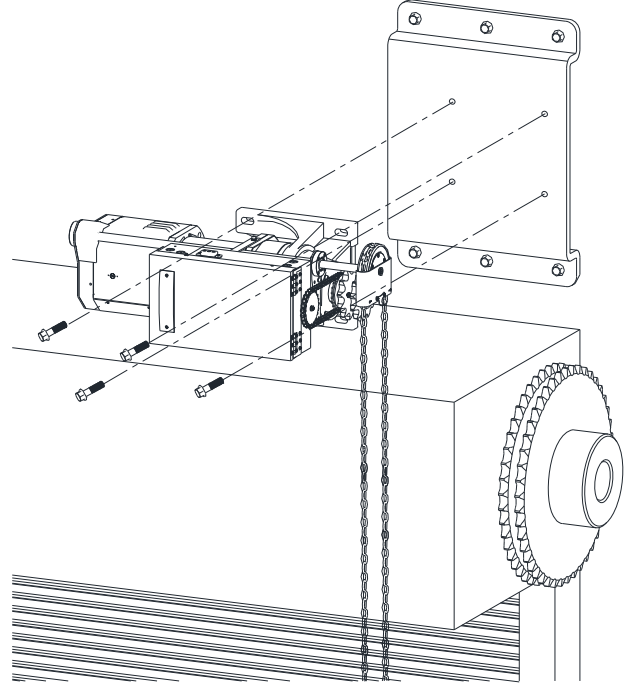

3. After mounting on operator at each side and before putting on the roller chain, checking the motor Rotation directions if both motors are correct through push the OPEN or CLOSE buttons.

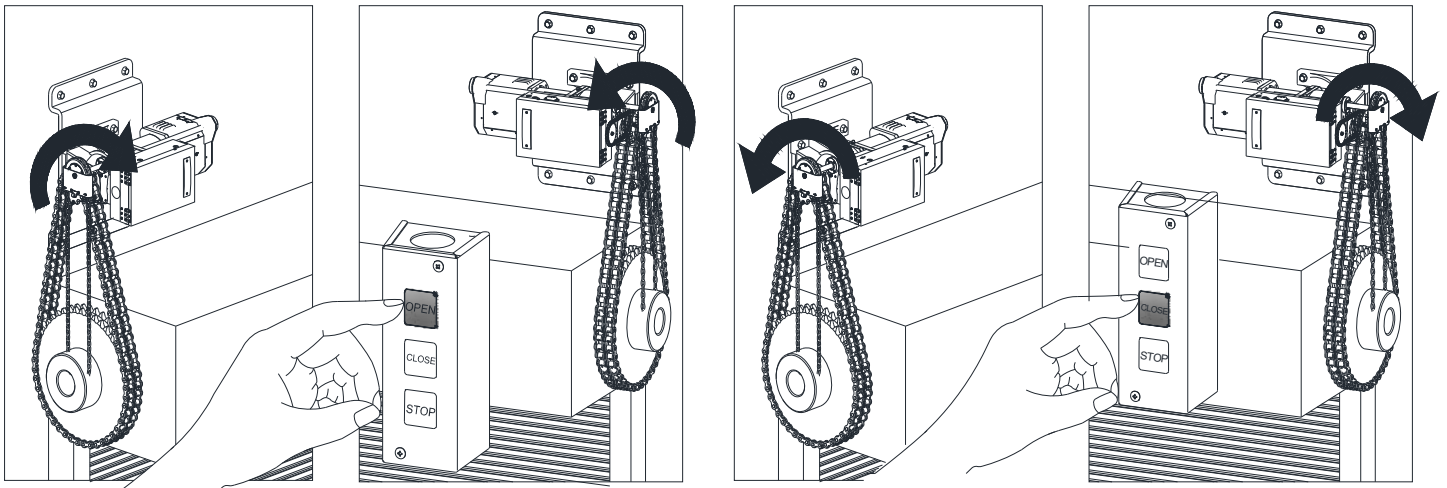

4. Install the roller chains.

Slave Operator

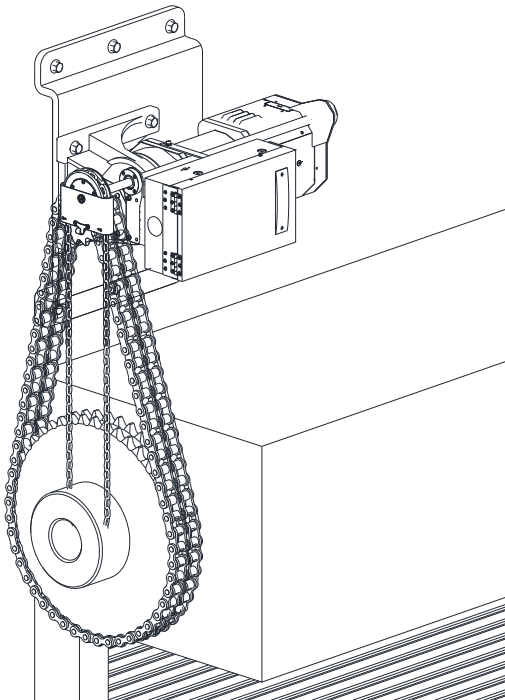

Master Operator

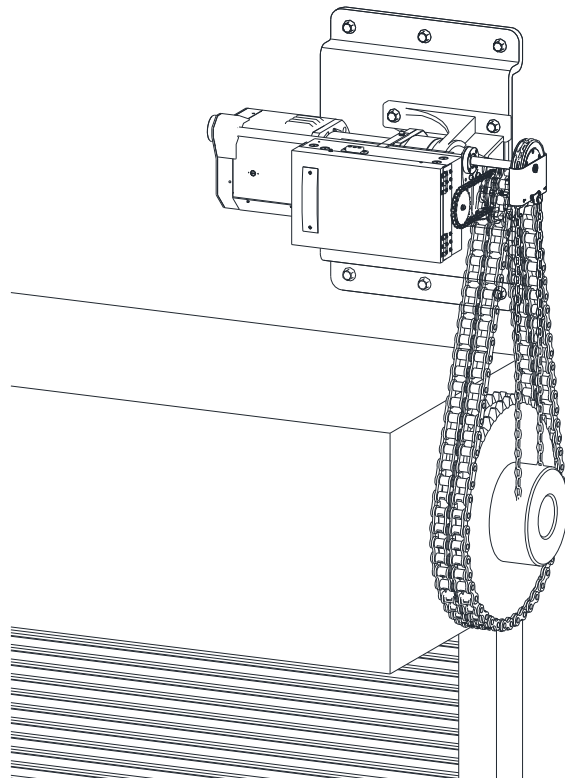

5. Completed.

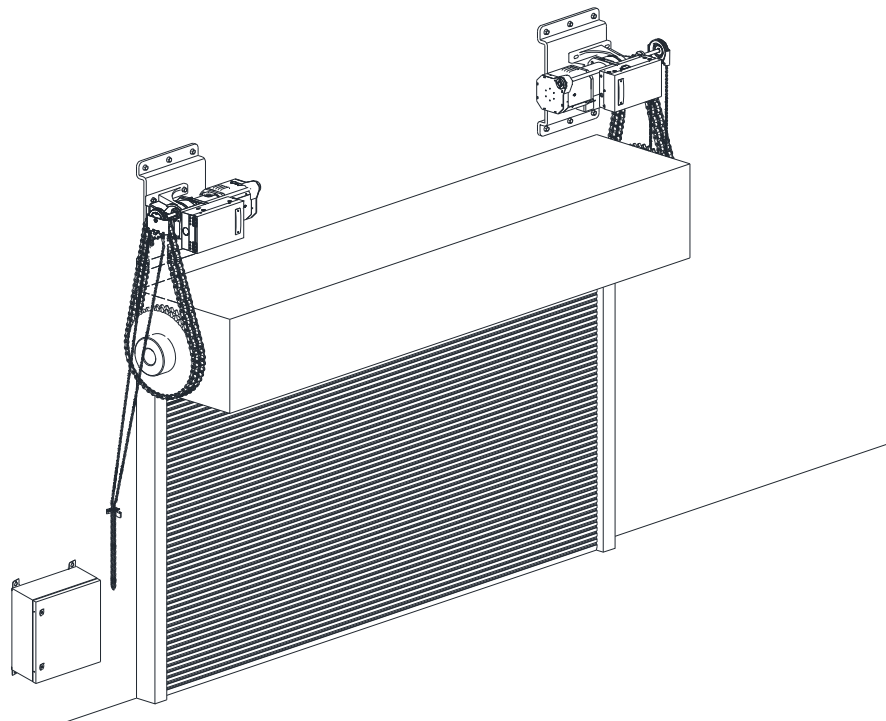
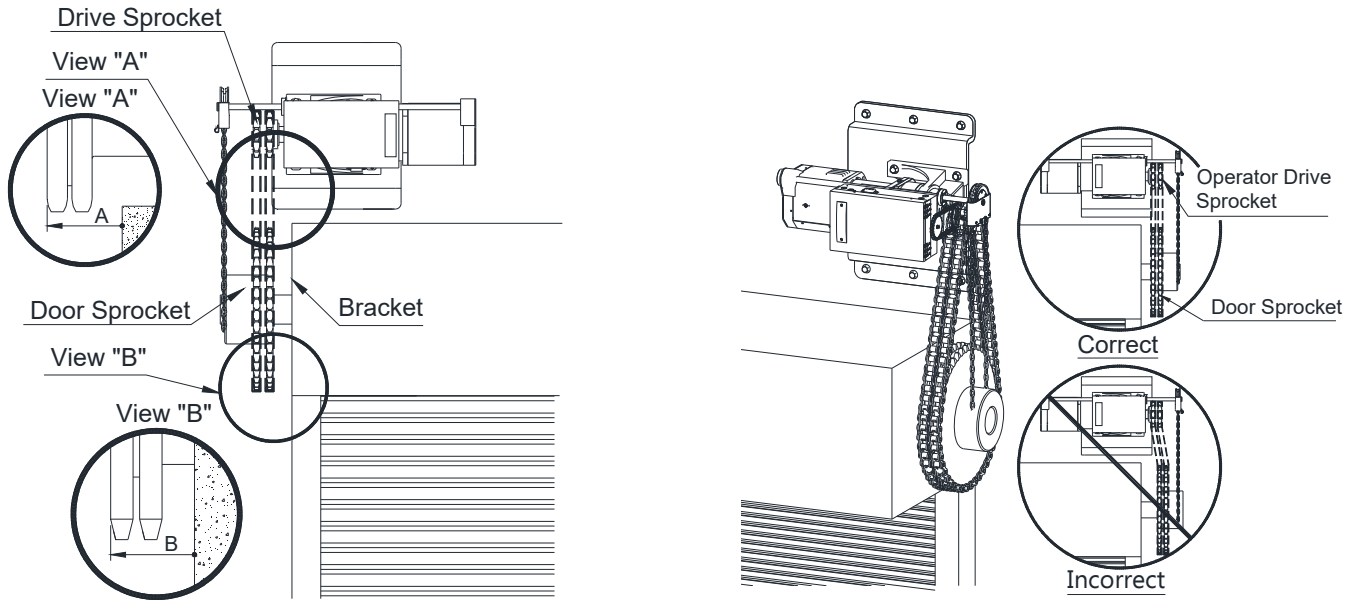

Illustration only, consult factory for changes in installation positions.

6. When the operator assembly is attached to the door bracket, be sure the door driven sprocket is properly aligned with the operator drive sprocket before securing the driven sprocket to the shaft.
7. The shelf or bracket must provide adequate support for the operator. Prevent play between the operator and the door shaft. The operator must be securely attached with the drive shaft parallel to the door shaft. It may be necessary to field brace the operator/bracket.



DRIVE CHAIN ADJUSTMENT

NOTE: Use correct type, size and proper length of roller chain.

1. Adjust the drive chain by tilting or move the operator so that there is about 1/4" of slack when the chain is depressed.
2. Once the drive chain has been tightened and the base leg screws have been set, and then tighten the operator screws.

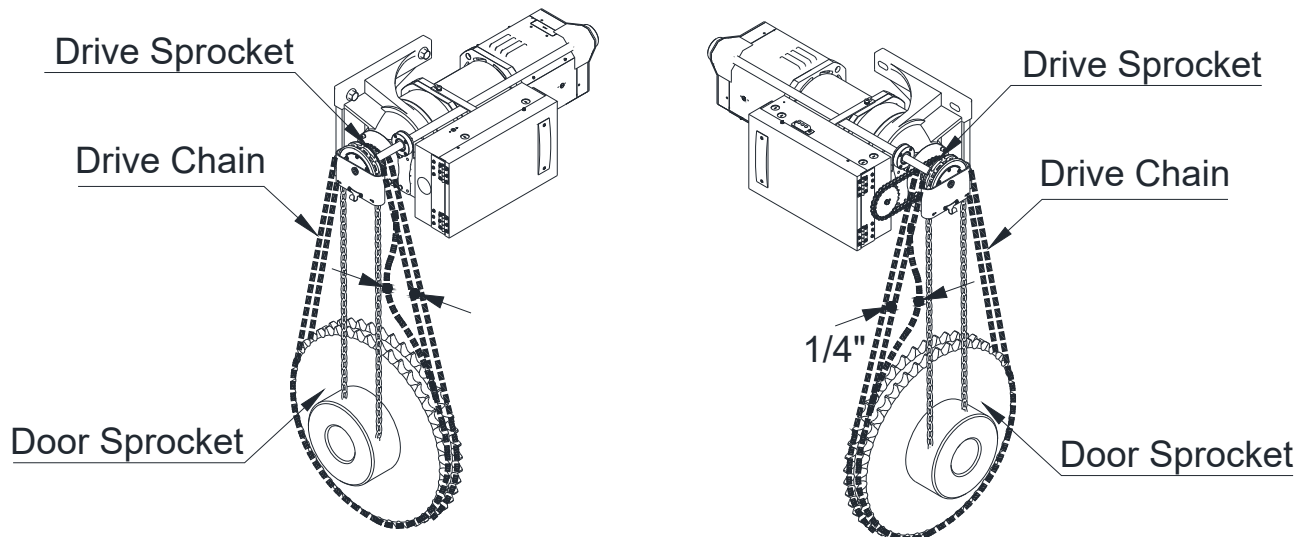

CHAIN HOLDER

Install at a convenient location.

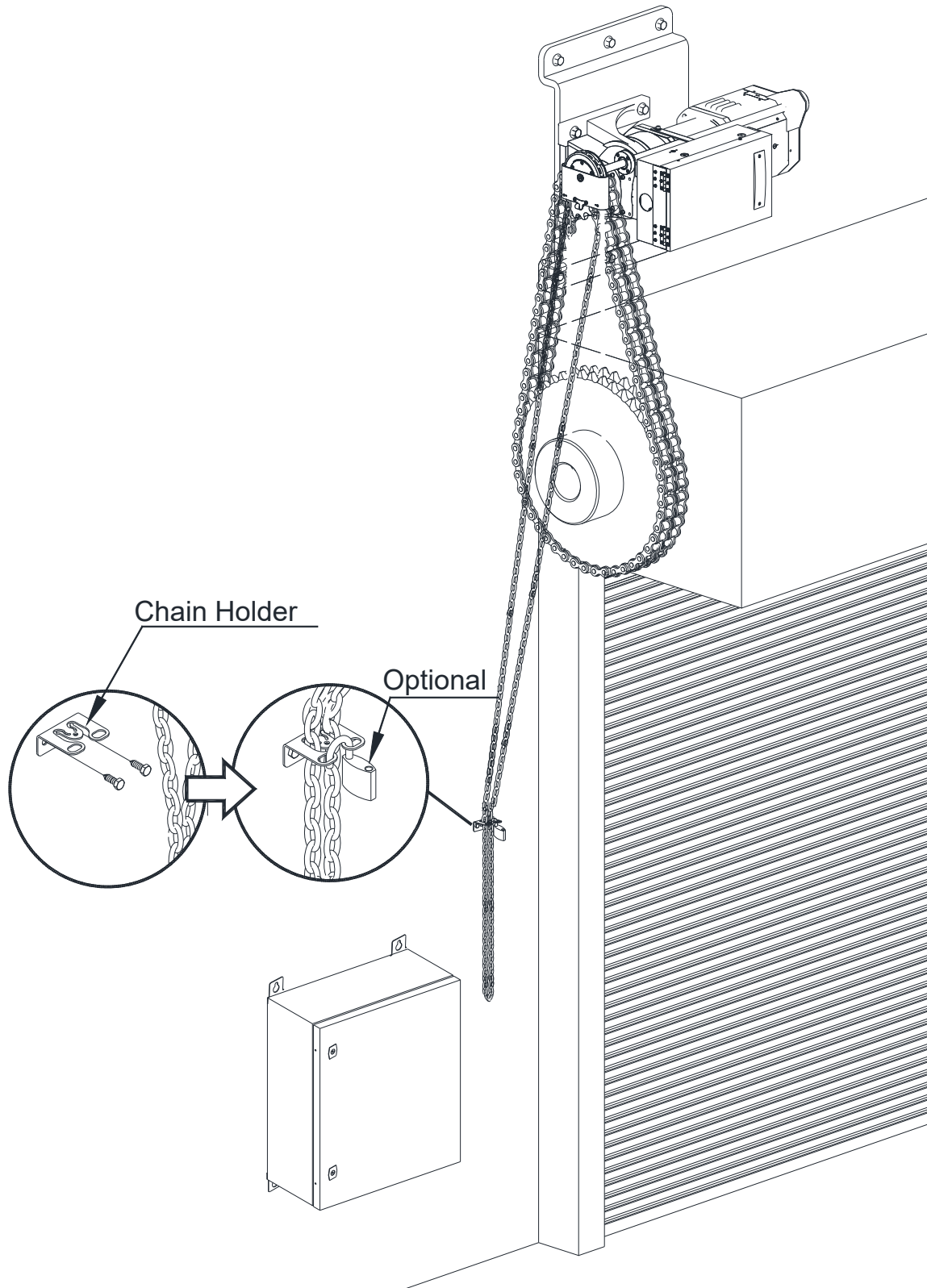

LIMIT SWITCH ADJUSTMENT

Make sure the limit cams are positioned between the limit switch actuators before proceeding with adjustments.

1. Open / Remove the control panel cover.
2. Open or close door to determine the moving direction of the limit switch cams.
3. Open or close door to the desired position.



Disconnect power before adjusting limit switch cams.

WARNING

4. While pressing the spring-loaded lever (G), which holds the limit switch cams in place, adjust the limit switch cam (E or F) until the micro switch (C or D) clicking sound is heard.
5. If the limit switch cam cannot be rotated to its desired position, release the lever and move the door away from the desired position, then adjust the limit switch cam to its desired position. It may be necessary to repeat this step until the exact position has been reached.
6. Repeat step 3 and 4 for the opposite position. Adjust close limit cams so that actuator is engaged as door fully seats at the floor.
7. Micro switch (A or B) can be adjusted to accommodate sensing edge cut-off position.

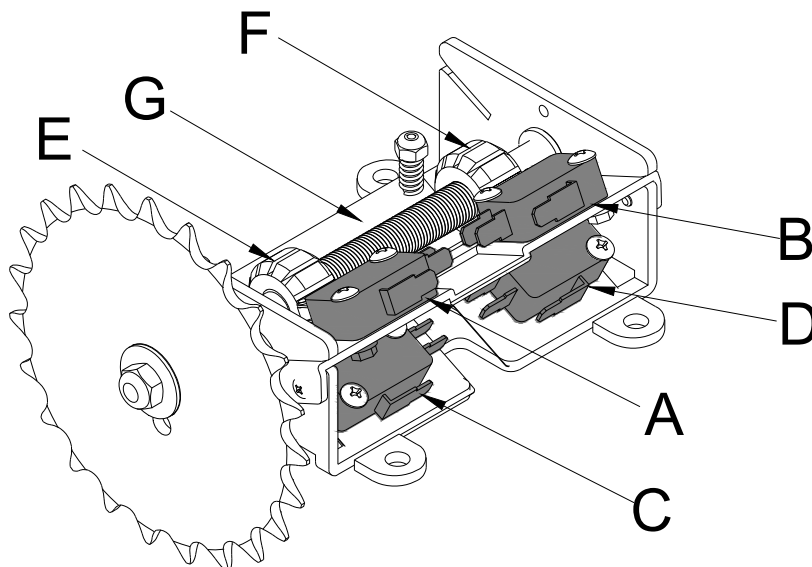

NOTE: “C” is usually the opening side and “D” is usually the closing side.

WIRING INSTRUCTIONS



Disconnect power at the fuse box before proceeding with any wiring.

WARNING

1. Do not install any wiring or attempt to run this operator without checking the wiring diagram located on the inside of the control box cover.
2. Do not turn on power until you have finished making all power and control wiring connections.
3. Do not run power and control wiring in the same conduit.
4. Any wire connected to the control panel must be protected by conduit or other means to ensure the safety and permanency of the wiring.
5. Use copper wire inside the control panel.
6. A separate circuit of adequate capacity is needed for the operator.
7. The operator must be properly grounded. The ground screw, painted green, is located inside the control panel.
8. For an operator, system, or external device requiring field installed wiring between a Class 2 output of an operator and an external device, the type of wiring shall be R/C (AVLV2/8), AWM, min. 22 AWG, rated 60°C, with VW-1/FT2.



Failure to properly ground the operator could result in electric shock and serious injury or death.

WARNING



To avoid damage to door and operator, make all door locks inoperative. Secure lock(s) in the unlocked position, or install electrical interlocks to prevent operation with the lock engaged.

WARNING

CONTROL WIRING



WARNING

If the door is not visible from the control station, or if any device other than the control station is used to activate the door, an entrapment protection device must be installed on the door. Failure to install an entrapment protection device may result in serious injury or death to person(s) trapped beneath the door.

1. Complete limit switch adjustments before making any sensing edge/non-contact device wiring connections to the operator.

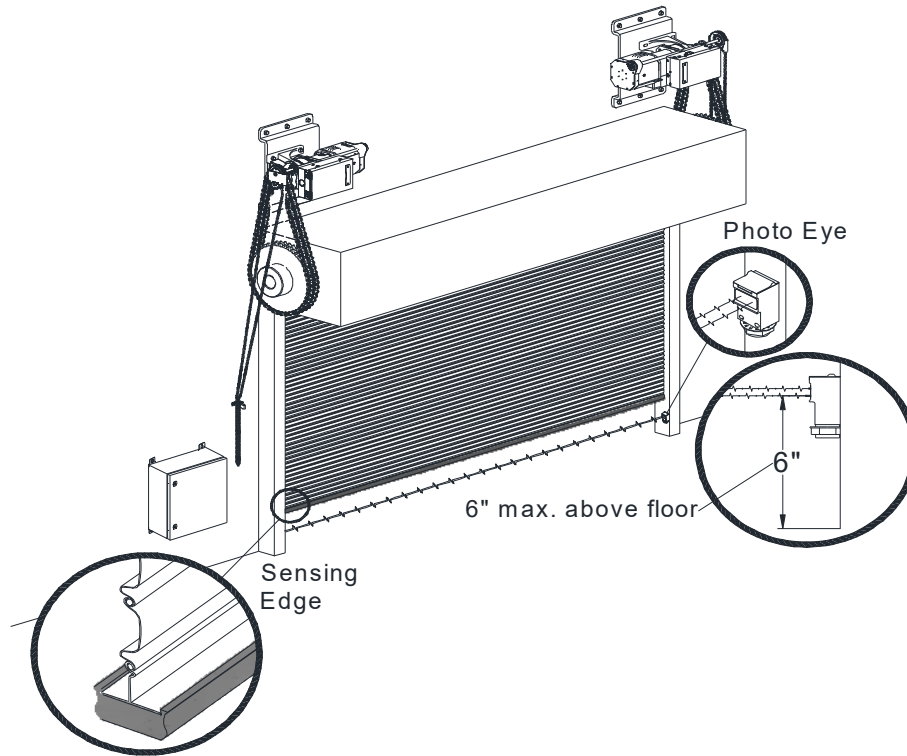

Entrapment Device Options:

Sensing Module	Device Manufacturer	Model
ELR 2-wire resistive sensing edge	Miller Edge Inc. * End of Line resistor type edge must have model number with Suffix T2.	ME110*, ME111*, ME120*, ME123*, ME112*, ME113*, ME116*, ME117*
		MT21*, MU21*, MT22*, MU22*, MC22*, MU33*, MC271*, CPT223*
		MEL-TXYY, MEL-RXYY
		RB-G-K10
	ASO	GE225, GE125, GE245, GE F45, GE F50, GE F56, GE F65, GE F85, GE F115
IR Monitored photo eye	FRABA Inc.	Optical Edge Sensors and Photo Eyes, Models OPTOEDGE, OPTOEYE, OSE, OPE, OSE-P, OSE-R, OSE-T, RAY-N Reflective Photo Eye, Models Ray/RT -1004, -2004
	Martec Access Products Inc.	1266
	Miller Edge Inc.	IG2, MIRM RB-D-K10

Note: Please refer to sensing device manufacturer for specific installation and maintenance requirements.



WARNING

Disconnect power at the fuse box before proceeding with any wiring.

2. Locate the control station where the user can clearly see the operation of the door. Mount the enclosed placard adjacent or near the door.



WARNING

Controls shall be far enough from the door, or positioned such that the user is prevented from coming in contact with door while operating the controls.

3. Do not run control wiring in the same conduit as power wiring.
4. Any wire connected to the control panel must be protected by conduit or other means to ensure the safety and permanency of the wiring.



WARNING

Do not use radio controls with your operator unless some type of entrapment protection device has been installed. Failure to do so may result in serious injury or death to person(s) trapped beneath the door.



WARNING

Changing from left hand to right hand or vice versa could result in change of control wiring. Consult factory for details.

5. After installation, be sure that the operator, controls, and sensing edge or other entrapment protection devices have been tested and function properly.

A. Control Overview:

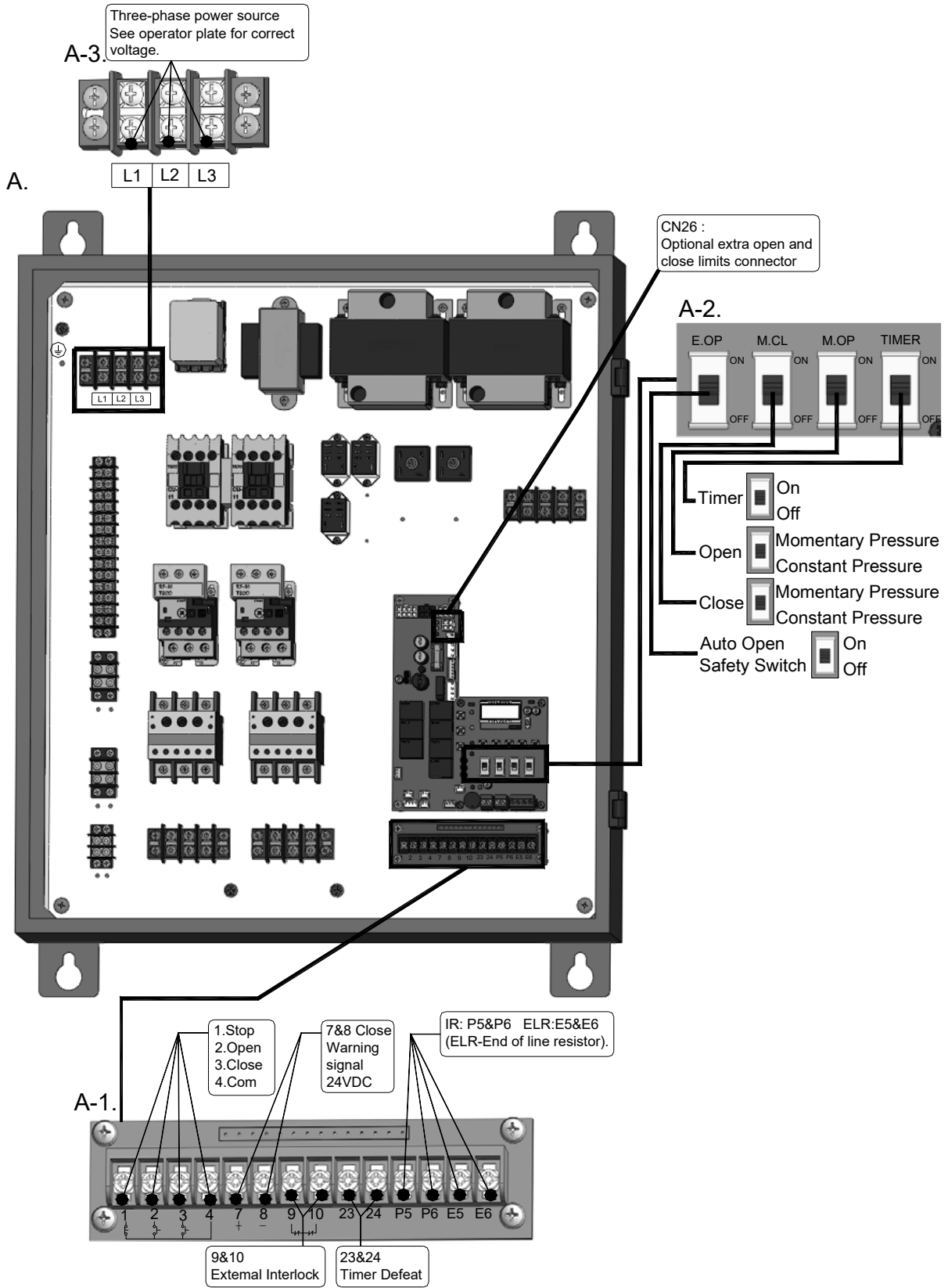

B. Auxiliary Function:

B

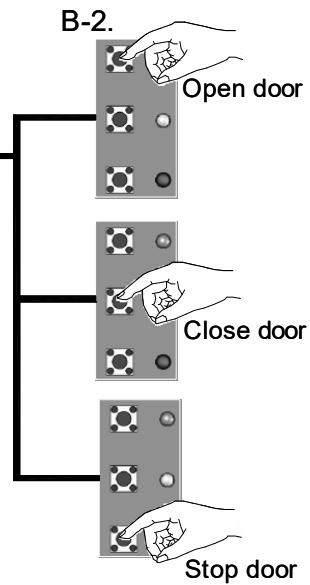
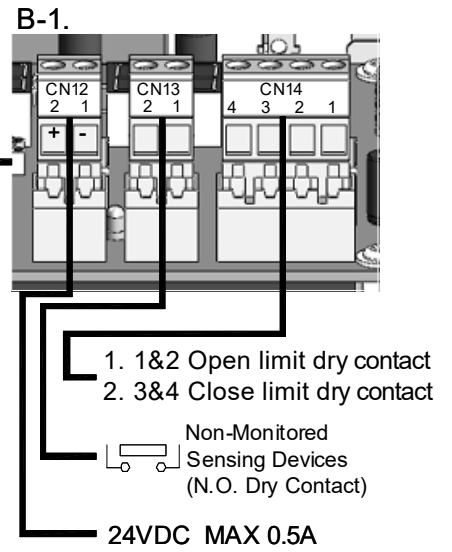
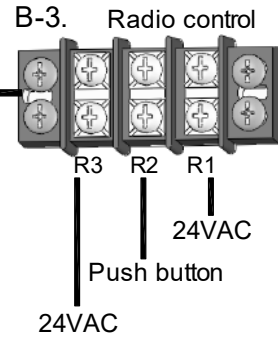
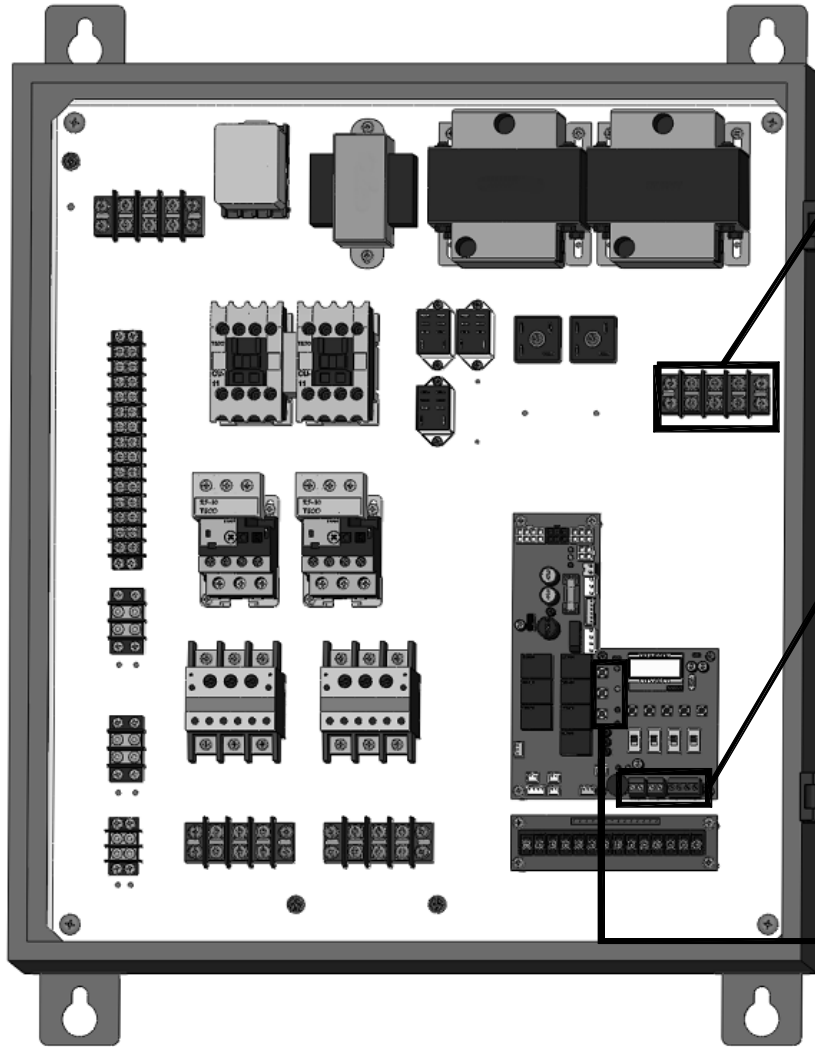

C. Timer Instruction:

Note: To enable timer(s) –

- 1) Must switch Timer Switch S10 to **ON**. (See figure A-2 on Page 12 for location.)
- 2) Must remove jumper on Terminal PCB-CN2 (23,24). (See figure A-1 on Page 12 for location.)

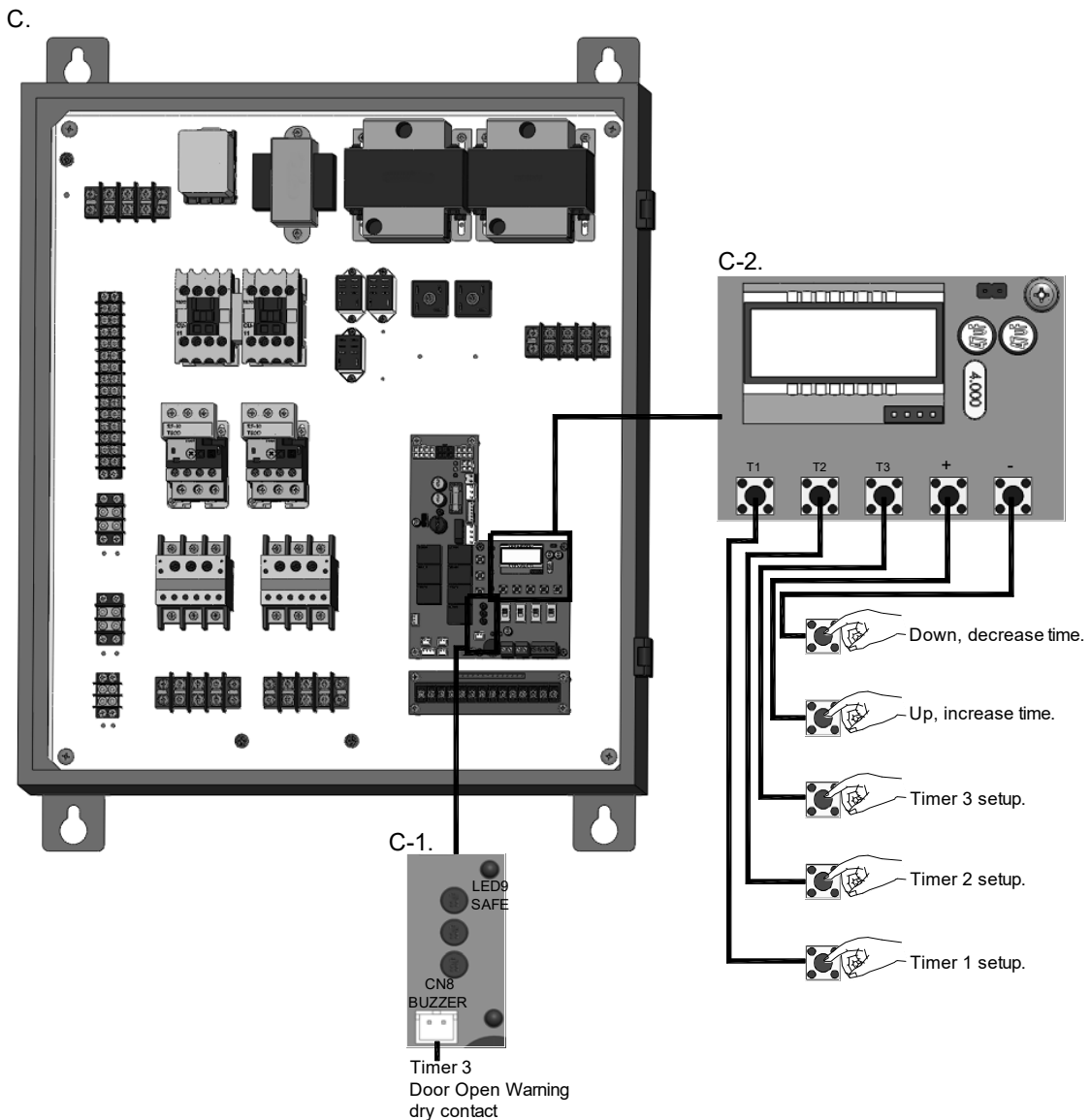





(1) T1 – Mid-open timer : Timer starts counting when door leaves close limit. Door stops after opening for set time. Pressing open again at mid-open position will cause door to open to open limit.

T2 – Timer to close : Timer is active when door stops and is not at close limit.

T3 – Door Open Warning Timer : Timer is active when door leaves close limit.
When time is up, contact will close. See figure C-1.



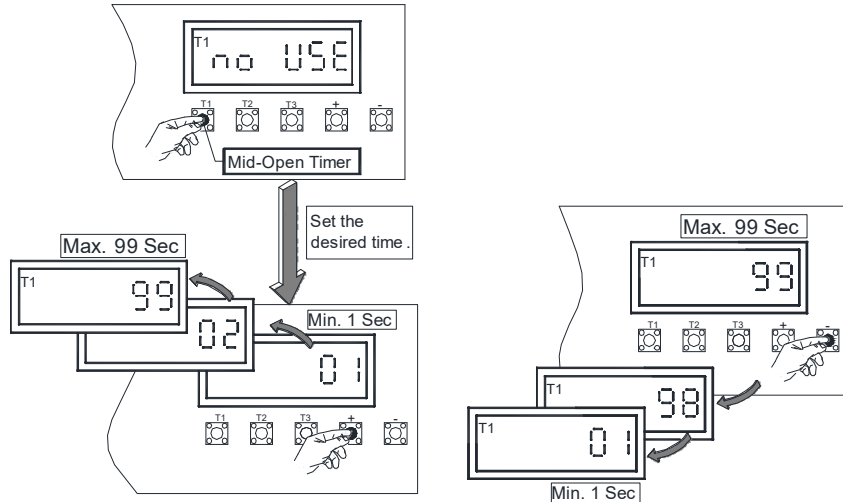

Terminals 23 and 24 External timer disable switch connection – jump to disable all timer functions or install a switch between 23 and 24. When the switch on 23, 24 is open and S10 switch is ON, all timers are enabled. When the switch on 23, 24 is closed or S10 switch is OFF, all timers are disabled.

(2) To Set Timer 1 (Mid-open Timer):

- Remove jumper from terminal (23,24) to enable Timers.
- Turn timer switch S10 to ON.
- Press  and hold for 5 seconds. Display will flash.
- Use  and  to increase or to decrease time.
- Press  to save setting. Without pressing, no adjustment is saved.





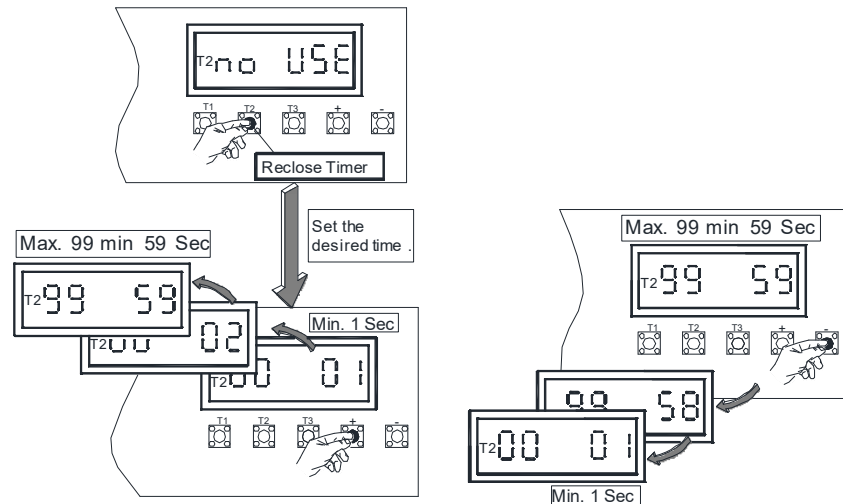

(3) To Set Timer 2 (Timer to close):

- Remove jumper from terminal (23,24) to enable Timers.
- Turn timer switch S10 to ON.
- Switch M.CL switch to ON. (See figure A-2 on Page 12 for location.)
- Press  and hold for 5 seconds. Display will flash.
- Use  and  to increase or to decrease time.
- Press  to save setting. Without pressing, no adjustment is saved.



(4) To Set Timer 3 (Buzzer Timer):

- Remove jumper from terminal (23,24) to enable Timers.
- Turn timer switch S10 to ON.
- Press  and hold for 5 seconds. Display will flash.
- Use  and  to increase or to decrease time.
- Press  to save setting. Without pressing, no adjustment is saved.

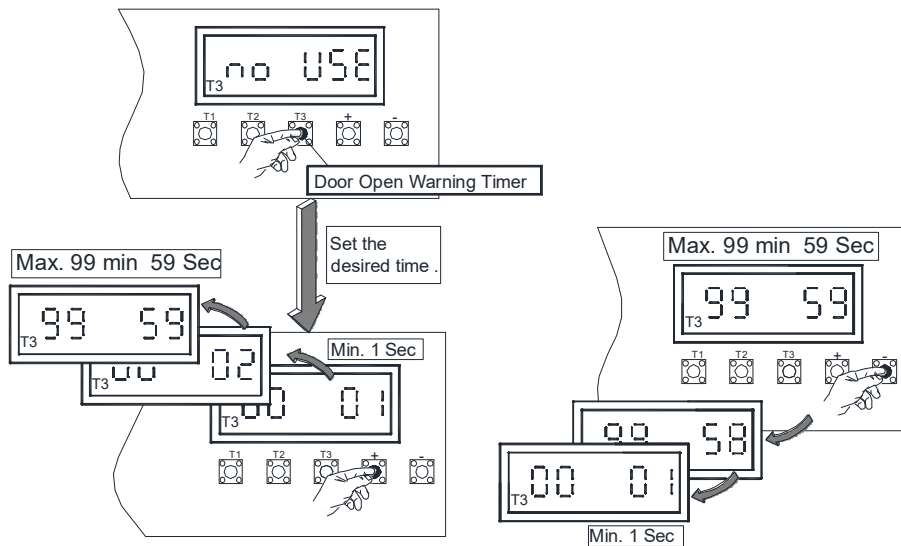

(5) To confirm timer value:

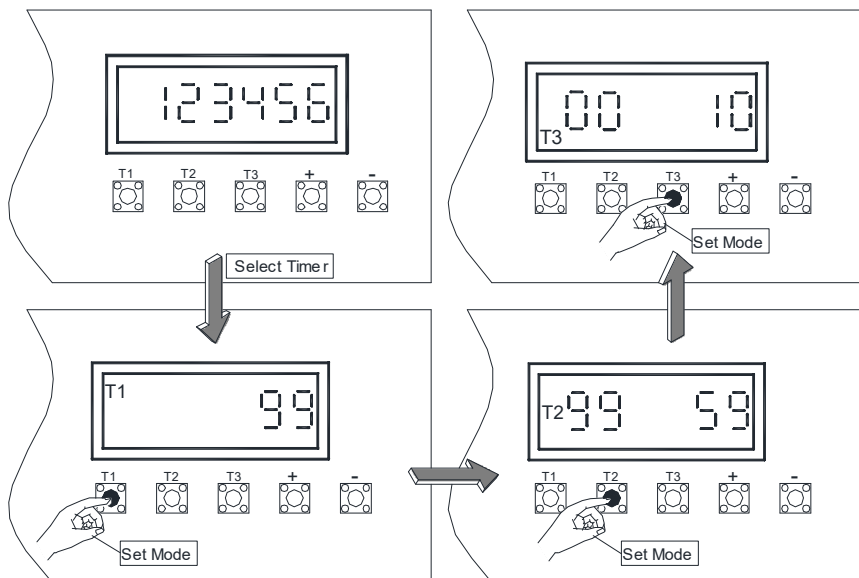

Note: To enable timer(s) –

- 1) Must switch Timer Switch to **ON**. (See figure A-2 on Page 12 for location.)
- 2) Must remove jumper on Terminal PCB-CN2 (23,24). (See figure A-1 on Page 12 for location.)

D. LCD Display Instruction:

Display	Status	Display	Status
	T1 setting		T1 or T2 or T3 setting completed
	T2 setting		Door closing
	T3 setting		Door opening

E. Light Indication:

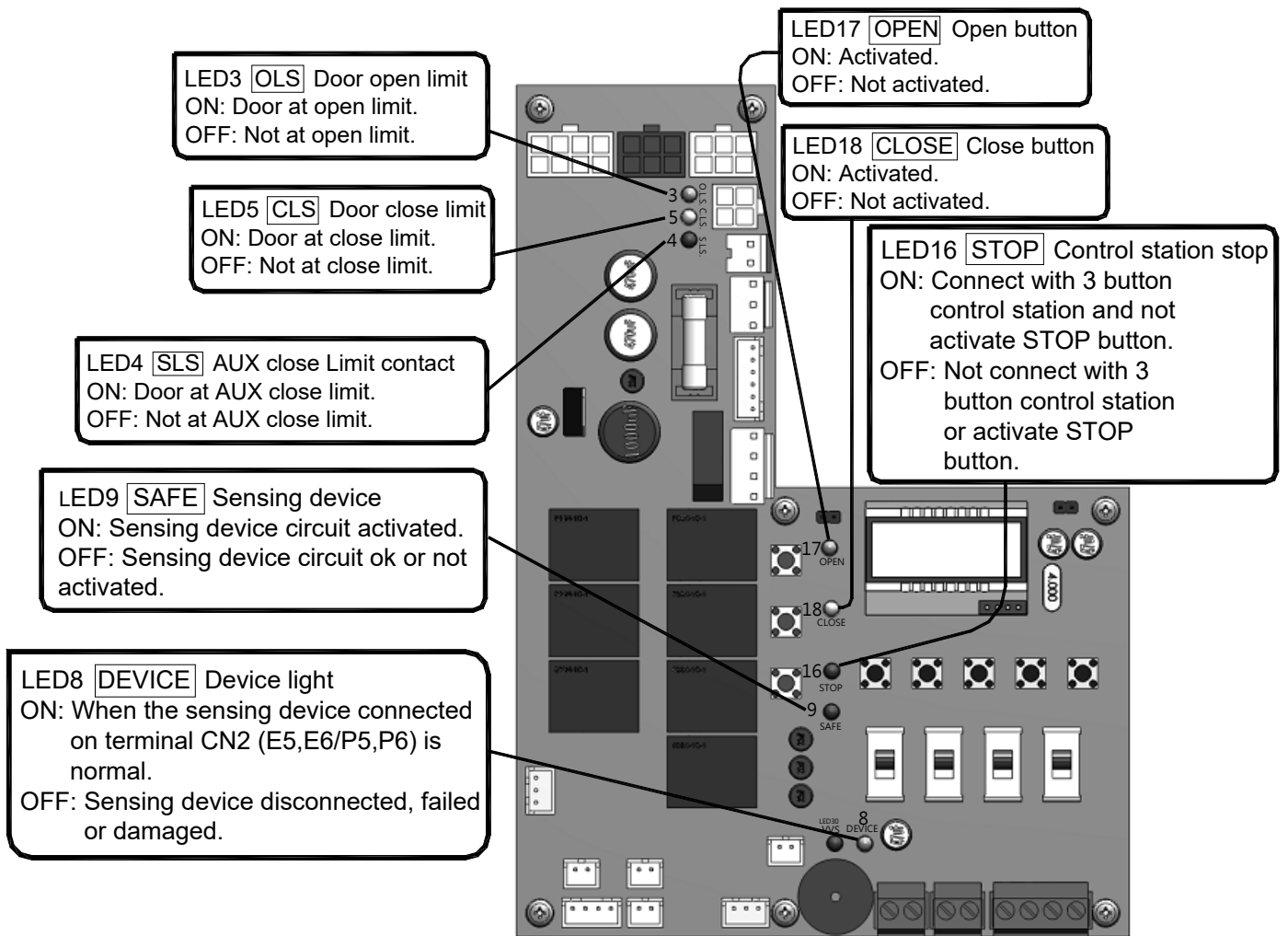

SGH 460V 3 PHASE 50/60HZ (V2)
 (FOR SGH 30043E, 50043E)
 DUAL OPERATORS SYSTEM - 2 MOTORS & 1 CONTROLLER
 CONTROL PANEL BOX A

EDBD 412ES A
AB01

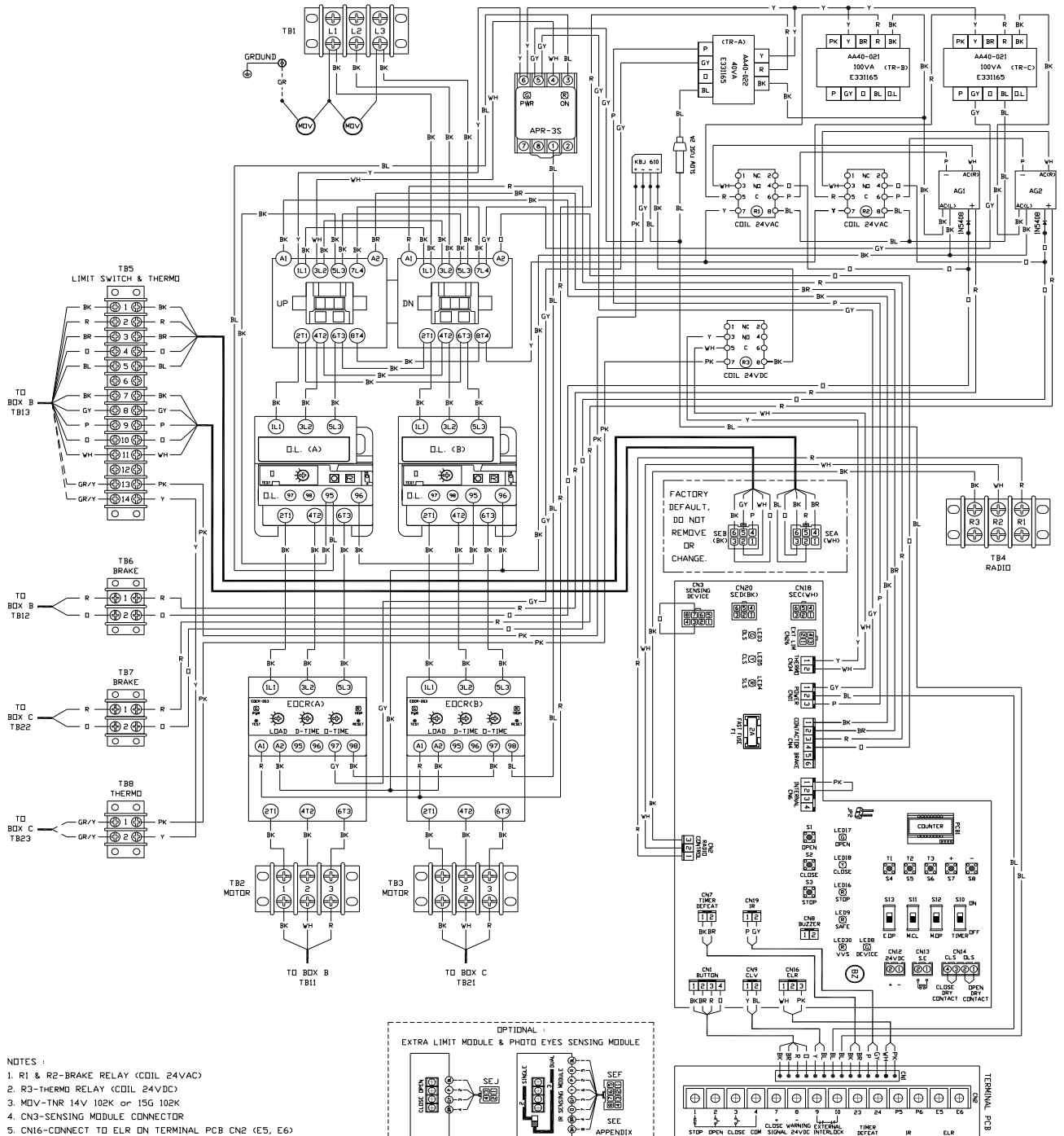

- NOTES :**
1. R1 & R2-BRAKE RELAY (COIL 24VDC)
 2. R3-THERMID RELAY (COIL 24VDC)
 3. MDV-TNR 14V 102K or 15G 102K
 4. CN3-SENSING MODULE CONNECTOR
 5. CN16-CONNECT TO ELR DN TERMINAL PCB CN2 (E5, E6)
 6. CN19-CONNECT TO IR DN TERMINAL PCB CN2 (P5, P6)
 7. CN26-OPTIONAL EXTRA OPEN AND CLOSE LIMITS CONNECTOR
 8. S10, S11, S12, S13 SETTING, AND S4, S5, S6, S7, S8 OPERATION (PLEASE SEE INSTRUCTION MANUAL)

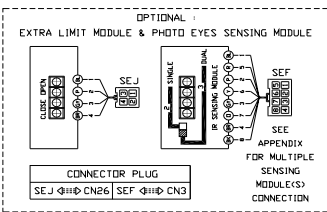

- TERMINAL PCB - CN2 :**
- | | |
|-------------------------------------|-------------------------------------|
| 1 CONTROL STATION-STOP | 23&24 JUMP FOR TIMER DEFEAT |
| 2 CONTROL STATION-OPEN | P5&P6 CONNECT TO IR SENSING DEVICE |
| 3 CONTROL STATION-CLOSE | E5&E6 CONNECT TO ELR SENSING DEVICE |
| 4 CONTROL STATION-COMMON | |
| 7&8 DDDR CLOSE WARNING SIGNAL 24VDC | |
| 9&10 EXTERNAL INTERLOCK | |

2018.11.01

SGH 460V 3 PHASE 50/60HZ (V2)
 (FDR SGH 30043E, 50043E)
 DUAL OPERATORS SYSTEM - 2 MOTORS & 1 CONTROLLER
 MOTOR PANELS BOX B & BOX C

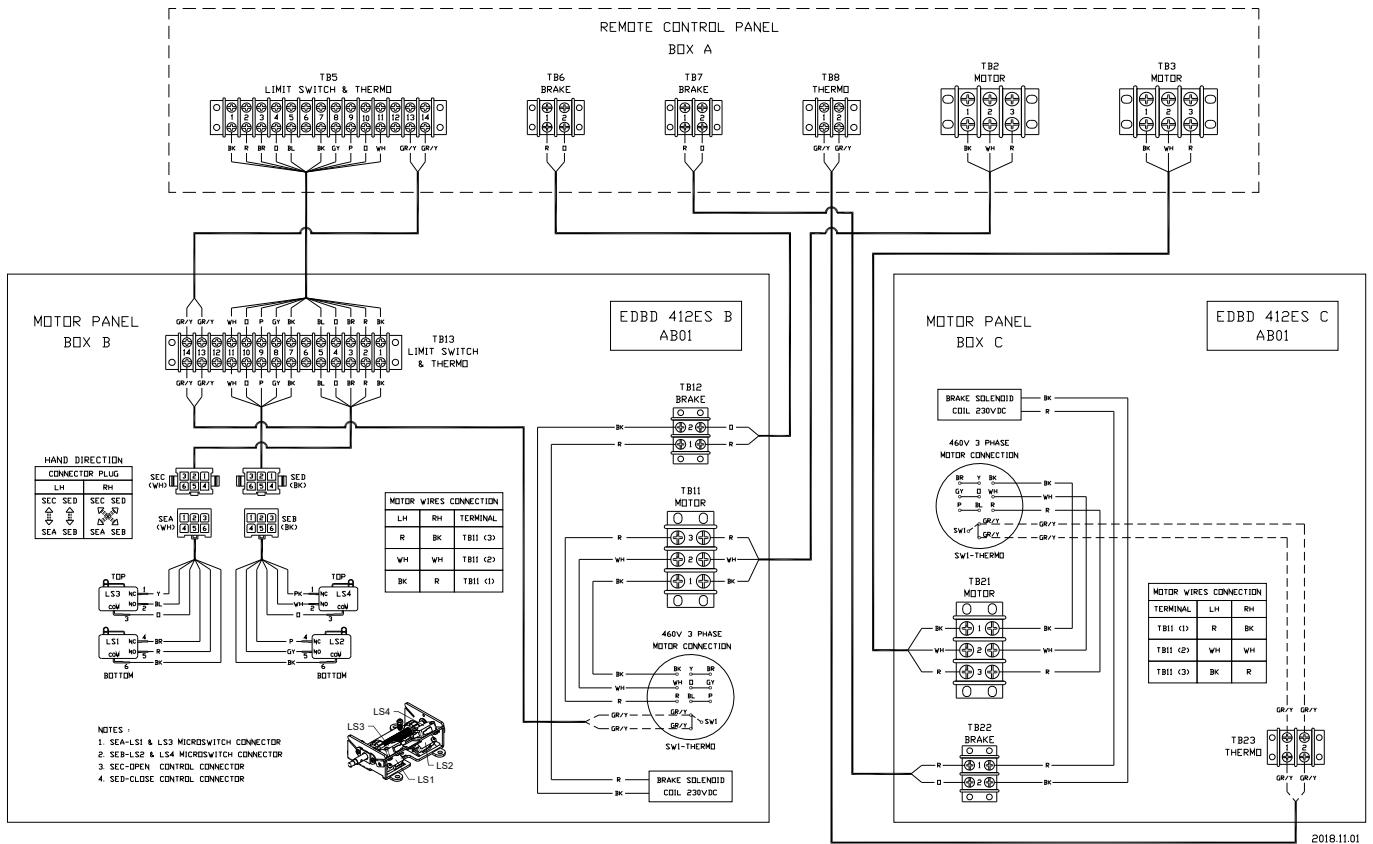

Reference
SGH series terminal connections

CN2													
1	2	3	4	7	8	9	10	23	24	P5	P6	E5	E6
Control Station Push Button				+	-	External Interlock		Timer Defeat		Photo eyes or IR sensing edge		ELR sensing edge	
Stop	Open	Close	Com	Close warning signal 24VDC		Jump when no external interlock is connected.							

- ❖ Control panel is wired with momentary pressure open and constant pressure close.
- ❖ A one-second delay on reverse is standard.
- ❖ When the door is closing, pushing the “Open” or “Stop” button will stop the door from moving.
- ❖ When the door is closing, the radio control transmitter can stop and reverse the door at anytime.

IMPORTANT SAFETY INSTRUCTIONS

WARNING –To reduce the risk of severe injury or death:

1. READ AND FOLLOW ALL INSTRUCTIONS.
2. Never let children operate or play with door controls. Keep the remote control (where provided) away from children.
3. Personnel should keep away from a door in motion and keep the moving door in sight until it is completely closed or opened. **NO ONE SHOULD CROSS THE PATH OF A MOVING DOOR.**
4. Test the door's safety features at least once a month. After adjusting either the force or the limit of travel, retest the door operator's safety features. Failure to adjust the operator properly may cause severe injury or death.
5. For products having a manual release, if possible, use the manual release only when the door is closed. Use caution when using this release when the door is open. Weak or broken springs may cause the door to fall rapidly, causing severe injury or death.
6. KEEP DOORS PROPERLY OPERATING AND BALANCED. See Door Manufacturer's Owner's Manual. An improperly operating or balanced door could cause severe injury or death. Have trained door systems technician make repairs to cables, spring assemblies, and other hardware.
7. **SAVE THESE INSTRUCTIONS.**

OPERATING INSTRUCTIONS

1. If a 3-button control station is used to operate the door, push the “OPEN” button to open the door, push the “CLOSE” button to close the door, push the “STOP” button to stop movement of the door while opening or closing. Removing pressure from the “CLOSE” button will cause the door to stop.
2. If a key switch control station is used to operate the door, turn the key to the “OPEN” position to open the door, turn the key to the “CLOSE” position to close the door, push the “STOP” button to stop movement of the door while opening or closing. Removing pressure from the “CLOSE” key position will cause the door to stop.
3. Door may also be operated by remote devices.

EMERGENCY MANUAL OPERATION

This operator has provisions for manually operating the door in case of emergency or power failure. This operator is equipped with an auxiliary hoist.

To operate the hoist:

1. Remove the hand chain from the chain bag.
2. Pull the hand chain to operate the door in the desired direction. (No clutch to engage)

Put the hand chain back into the chain bag, before operating the door again electrically.



WARNING

Turn off power to the operator before manually operating the door.



WARNING

Hand chain must be kept inside chain bag when operating electrically.

MAINTENANCE INSTRUCTIONS

The brake is a self-adjusting brake. It is maintenance free. The brake assembly requires no additional adjustments for its lifetime.

If an entrapment protection device is used, i.e. sensing edge or photoelectric sensors, please consult the manufacturer for maintenance instruction.



Disconnect power supply to the operator before servicing.

WARNING

Check the following items at the intervals listed:

CHECK LIST	DESCRIPTION	EVERY 3 MONTHS	EVERY 6 MONTHS	EVERY 12 MONTHS
Drive Chain	Check for excessive slack. Check & adjust as required Lubricate.	●		
Sprockets	Check set screw tightness	●		
Fasteners	Check & tighten as required		●	
Bearings & Shafts	Check for wear & lubricate	●		

- ❖ Do not lubricate motor. Lubrication could cause damage.
- ❖ Inspect and service whenever a malfunction either door or operator is observed or suspected.
- ❖ Before servicing, always disconnect power supply to the operator.
- ❖ Replace fuses only with those of the same type and rating.
- ❖ All replacement parts must be compatible with those originally provided. Consult manufacturer for replacement parts.



WARNING

Do not place hands or tools in or near the operator when the power is connected or when testing control or sensing devices. Always disconnect power before servicing or adjusting the operator.

U.S. GEAR

Covered under US Pat. #6,055,885, #6,900,602 and additional patents pending.

APPENDIX 1

Multiple Sensing Devices Connection Instruction Dual Photo eyes Connection Module

Warning: Power OFF When Connecting.

QST-SGD-SB- ADAPTER -2

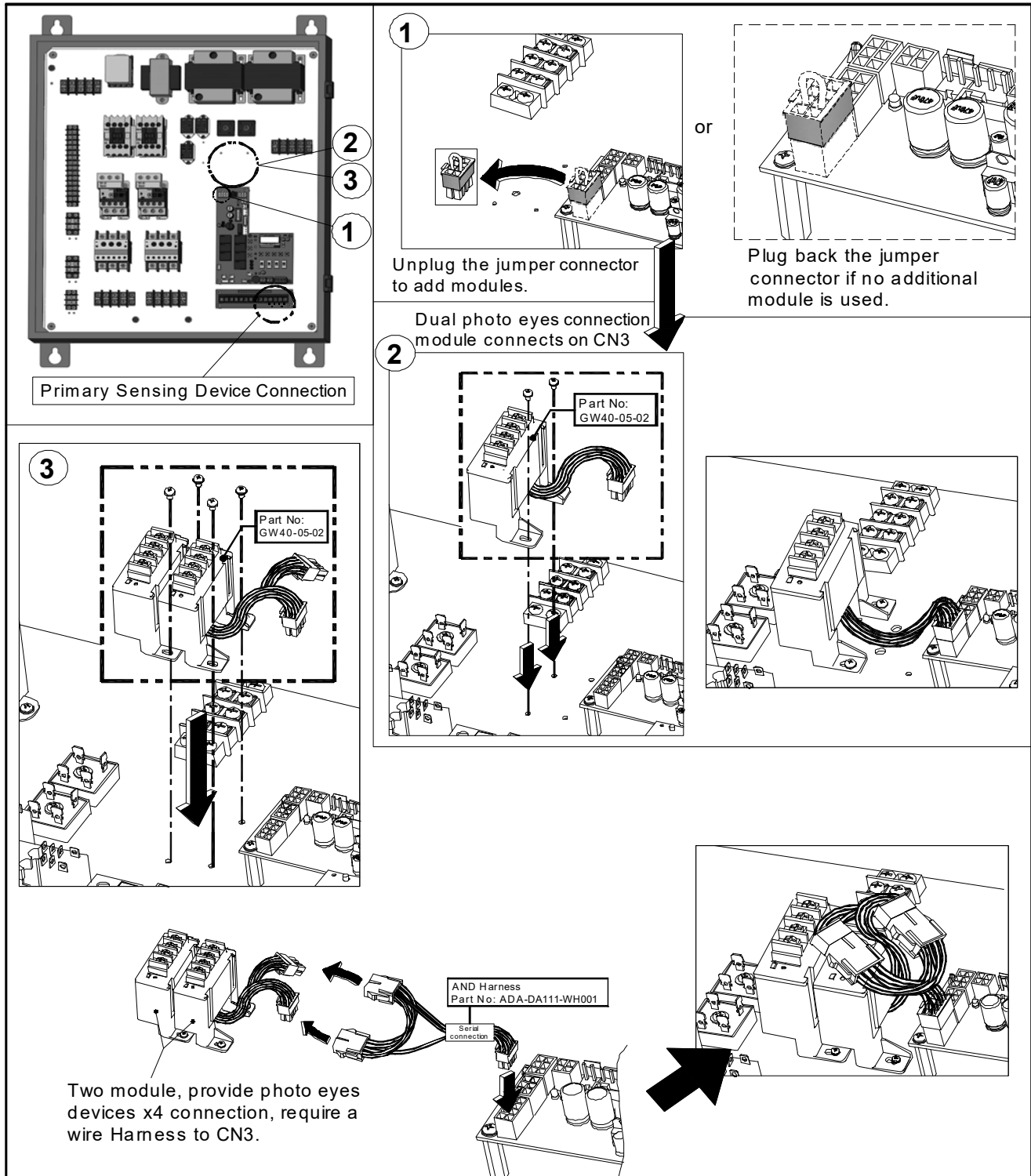

APPENDIX 2

Control Connections Diagrams

CCD-PCB-A01

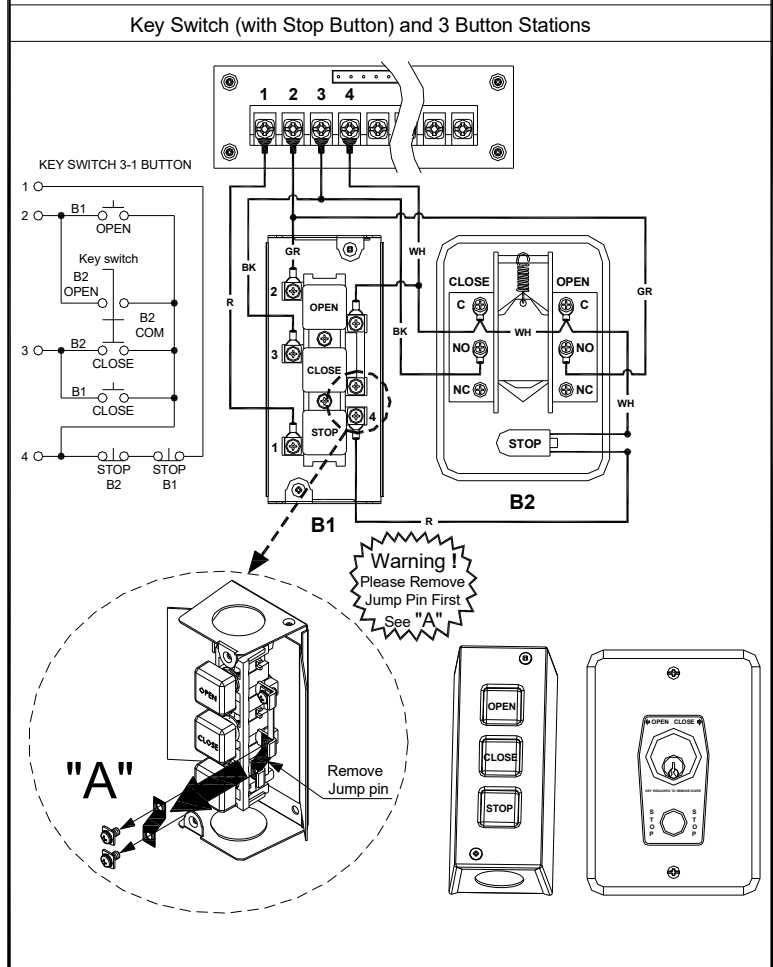
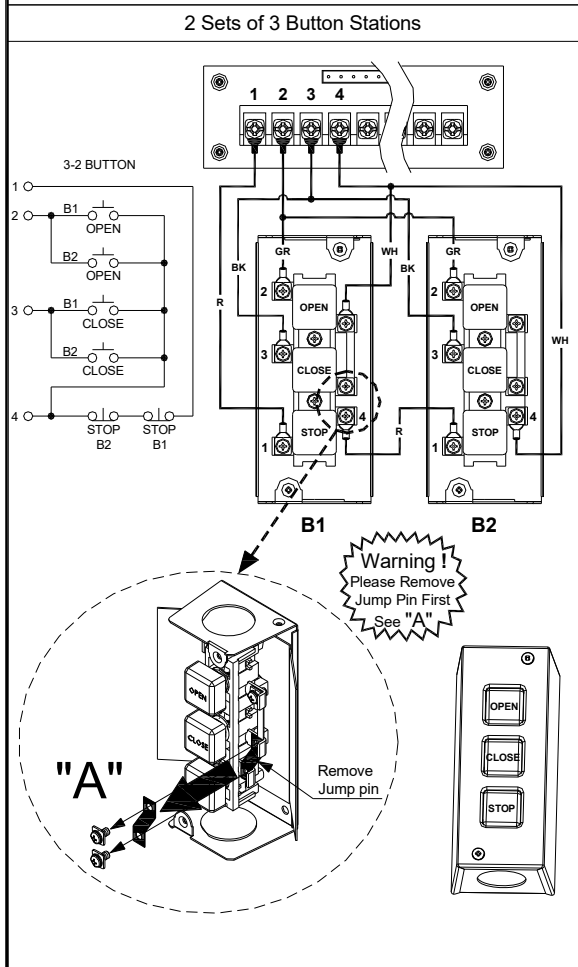
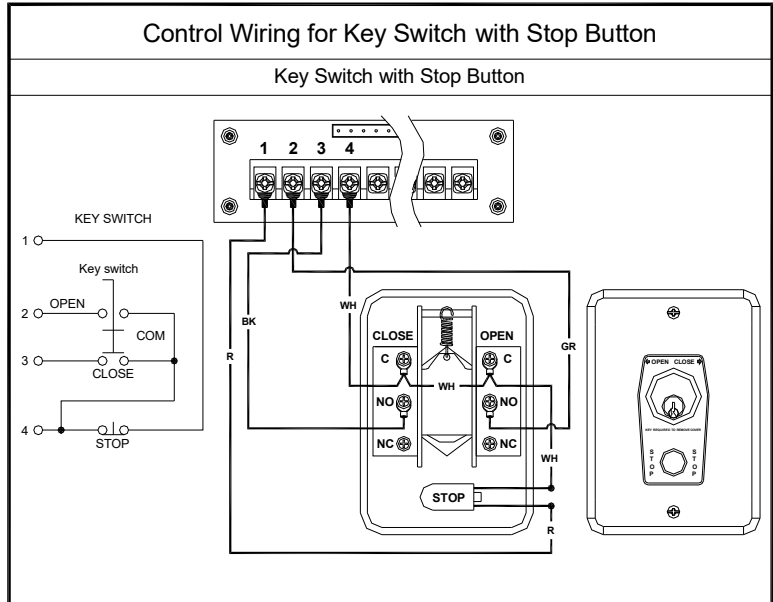
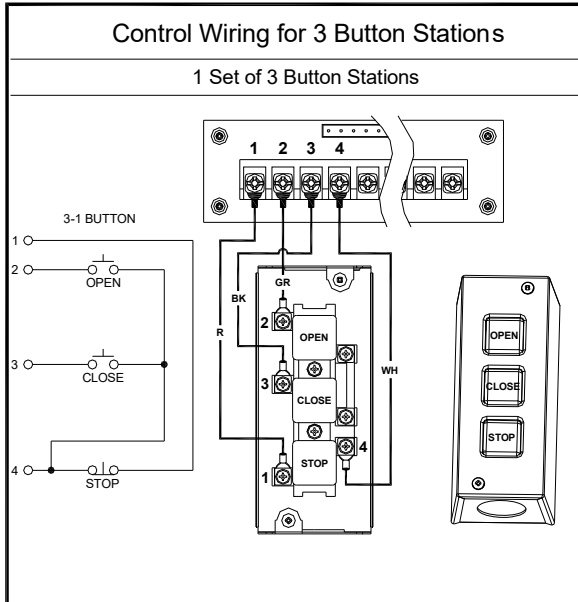

APPENDIX 3

Control Connections Diagrams

CCD-PCB-B02

Wiring 3 Button Stations With Key Lockout

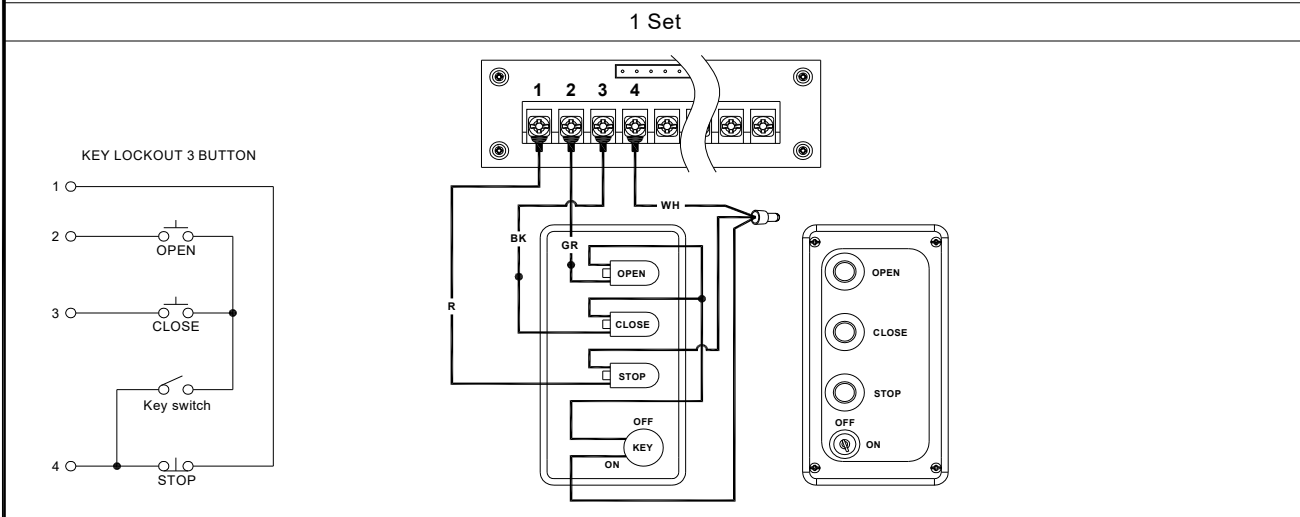

With and without key lockout

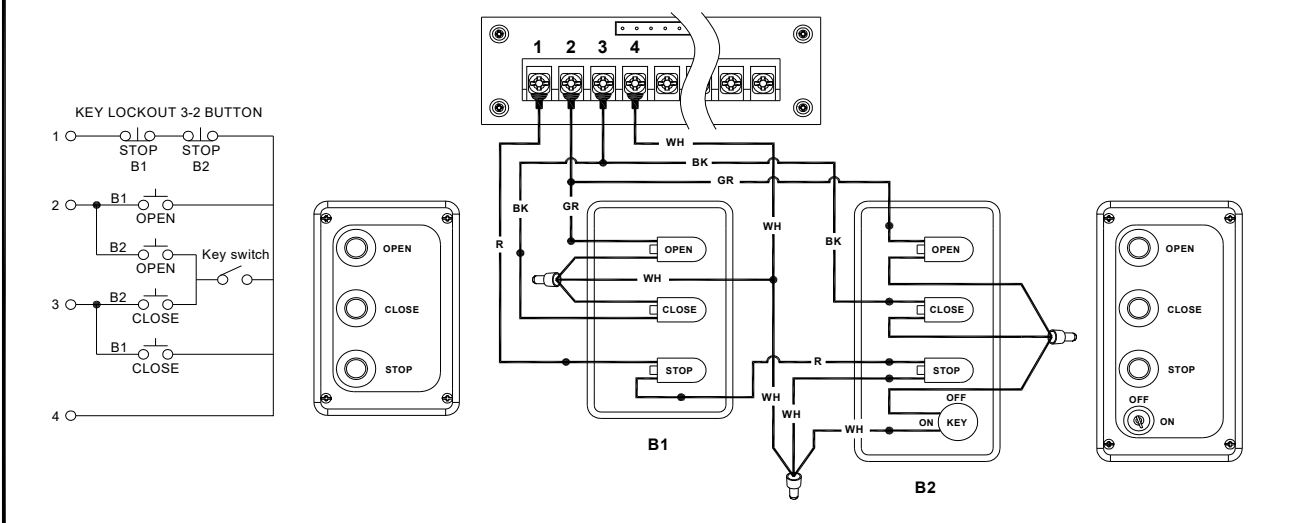

Ceiling Pull Switch Station

