



INSTALLATION INSTRUCTIONS

AND

OPERATION MANUAL

MGHC Series 380V/400V/415V

(Damp Environment)

UL325-2010 Compliant

Commercial and Industrial Door Operator

Logic Control

Duty Cycle – 20 Cycles per Hour

IMPORTANT INSTALLATION INSTRUCTIONS

WARNING – To reduce the risk of severe injury or death to persons:

1. READ AND FOLLOW ALL INSTALLATION INSTRUCTIONS.
2. Install only on a properly operating and balanced door. A door that is operating improperly could cause severe injury. Have qualified service personnel make repairs to cables, spring assemblies, and other hardware before installing the operator.
3. Remove all pull ropes and remove, or make inoperative, all locks (unless mechanically and/or electrically interlocked to the power unit) that are connected to the door before installing the operator.
4. Install the door operator at least 8 feet or more above the floor if the operator has exposed moving parts. If the operator must be mounted less 8 ft (2.44 m) above the floor, then exposed moving parts must be protected by covers or guarding. Contact the manufacturer.
5. Do not connect the door operator to the source of power until instructed to do so.
6. Locate the control station: (a) within sight of the door, and (b) at a minimum height of 5 feet above floors, landings, steps, or any other adjacent walking surface and (c) away from all moving parts of the door.
7. Install the Entrapment Warning Placard next to the control station in a prominent location.
8. Make sure the available power supply to be connected to the operator is of the same voltage, frequency, phase and wattage as indicated on the nameplate of the operator.
9. Read and understand the wiring diagram of the operator and the control station (open-close-stop push button), and any other equipment to be connected to the operator.
10. To avoid damage to the door and operator, make all door locks inoperative. Secure locks in the unlocked position, or install external electrical interlocks to prevent operation with the locks engaged.
11. Always disconnect power whenever installing or servicing the door operator or door.
12. All wiring must be permanent and comply with National Electrical Code (NEC) and local code requirements.
13. Any change in mounting position may result in a change of operator rotation and consequently in a change of control functions. Consult factory for any changes.
14. If the operator is provided with an auxiliary chain operator, the hand chain must be kept inside the chain bag when operating electrically.
15. For products having a manual release, instruct the end user on the operation of the manual release.

SPECIFICATIONS

MOTOR	
Duty Cycle:	20 cycles per hour
Horsepower:	3/4hp
Speed:	50Hz – 1400 RPM, 60Hz – 1700 RPM
Voltage:	380V/400V/415V – 3 phase
Current:	See motor nameplate
ELECTRICAL	
Transformer:	24VAC
Wiring Type:	Momentary pressure open, stop, constant pressure close (provided standard), with provision for momentary pressure close*
Limit Adjustment:	Linear driven, fully adjustable screw type cams.
MECHANICAL	
Drive Reduction:	43:1
Output Shaft Speed:	50Hz - 32 RPM, 60Hz – 39 RPM
Door Speed:	6 - 8" per sec. average (typical)
Brake:	Solenoid actuated brake
Emergency Chain Hoist:	Standard
ENTRAPMENT PROTECTION	
Sensing Edge*:	(Optional) Sensing device attached to the bottom edge of the door.
Non-Contact Device*:	(Optional) Photo eye device.
* Per the requirements of UL Standard 325, the door operator is setup for constant pressure to close the door. As an alternative, the door may be provided with a monitored entrapment protection device that will reverse the door upon contact with or detection of an obstruction during closing. Adding an entrapment device would enable momentary close operation.	

***Note:**

1. Non-contact device (photo eye) can be used on doors up to 45 ft. wide (or maximum rated range of device if less than 45 ft.). Use a sensing edge to provide entrapment protection on doors over 45 ft. wide.
2. Sensing edge can be used on all doors.

TYPES AND SIZES OF DOORS

Consult factory for details.

INSTALLATION INSTRUCTIONS

INSTALLATION POSITIONS

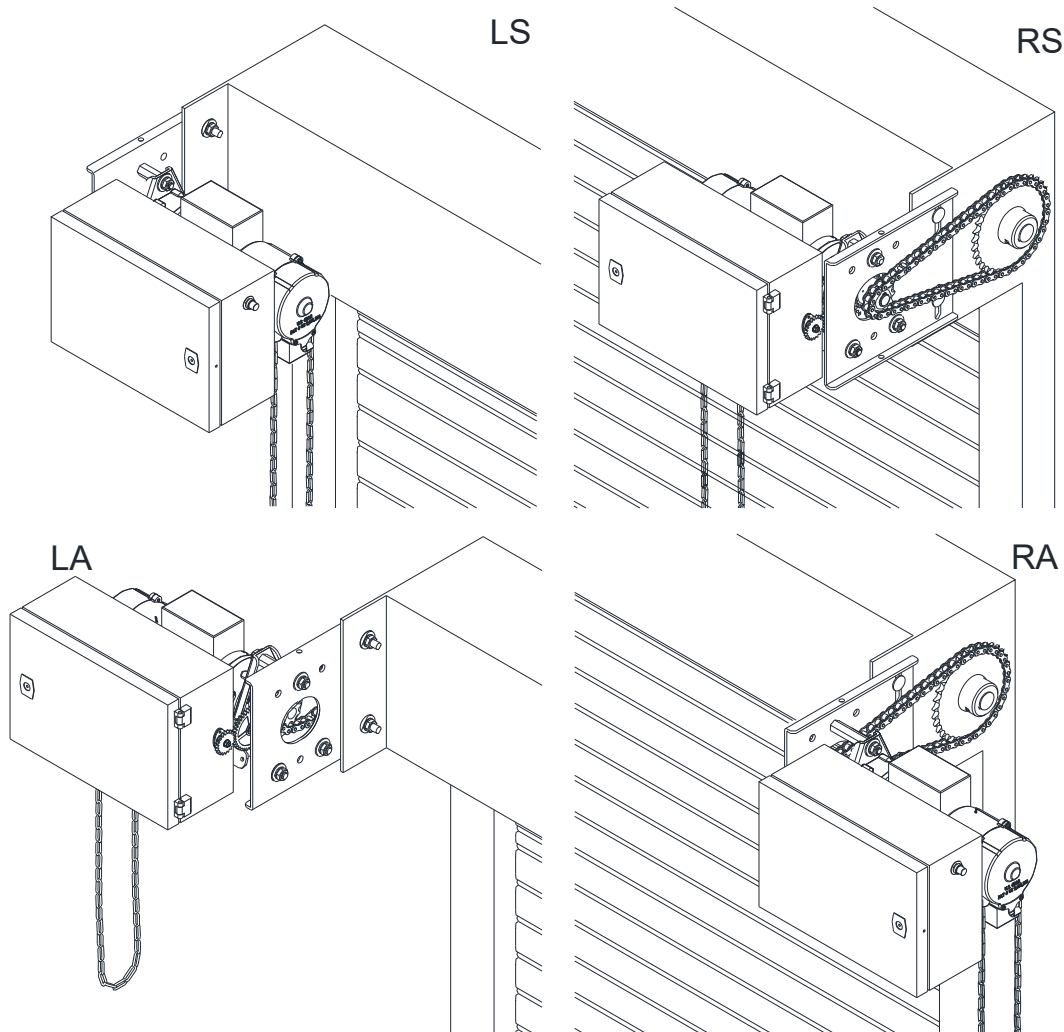

Consult factory for changes in installation positions.

NOTE: Any change in mounting position may result in a change of operator rotation and consequently in a change of control functions. Consult factory for any changes. (LH=LS and RA, RH=RS and LA)

Operators mounted in alternate positions (LA, RA) require the long mounting legs in lieu of the standard short mounting legs.

OPERATOR MOUNTING

1. Before the operator is installed, verify that the door is properly operating and balanced.
2. Make sure the layout of the mounting holes on the bracket is correct.
3. Bolt the operator mounting plate to the door bracket plate.
4. Attach and tighten the three mounting legs to the mounting plate.
5. Mount the operator to the three legs and tighten.

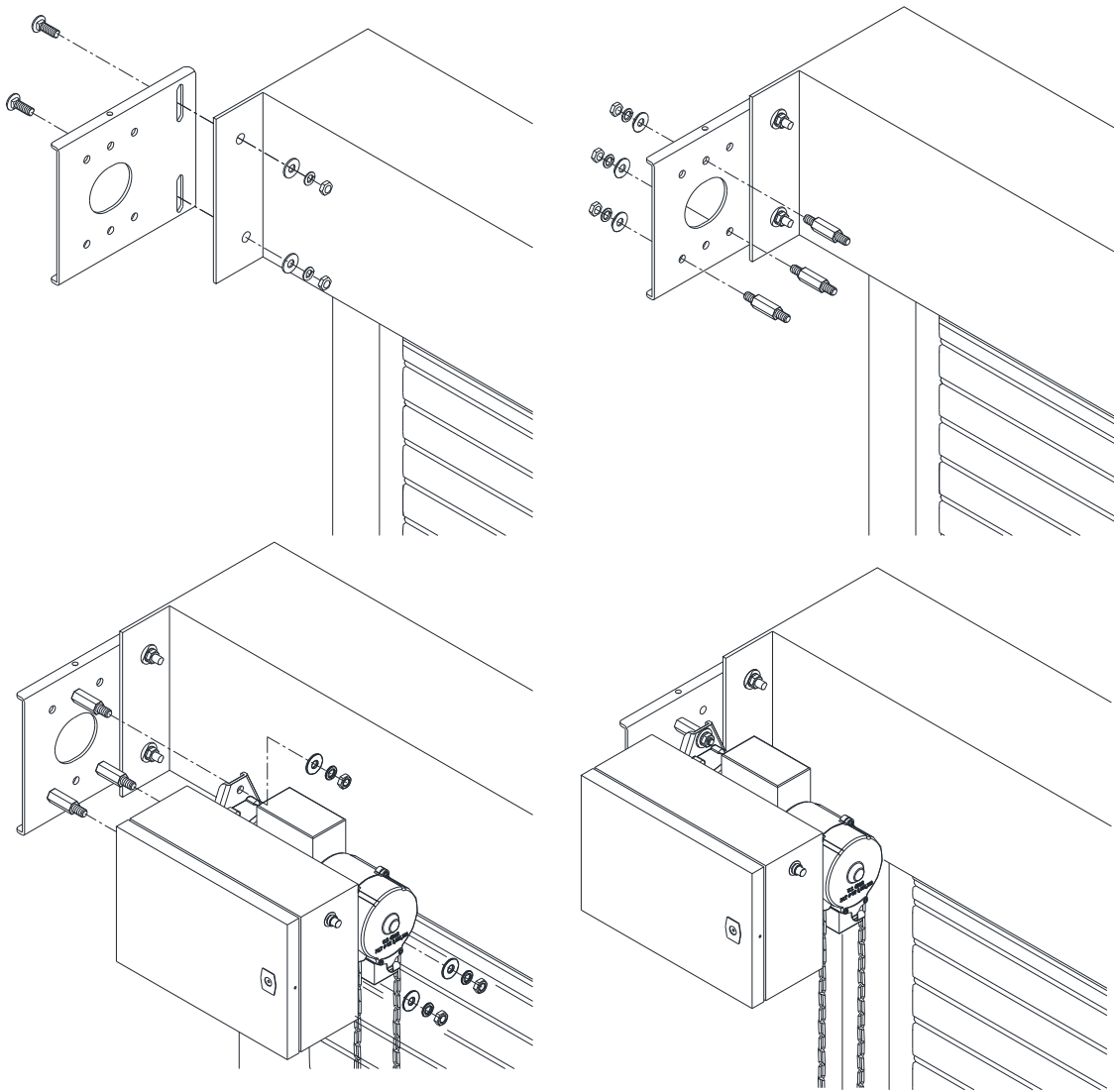

6. When the operator assembly is attached to the door bracket, be sure the door driven sprocket is properly aligned with the operator drive sprocket before securing the driven sprocket to the shaft.
7. The shelf or bracket must provide adequate support for the operator. Prevent play between the operator and the door shaft. The operator must be securely attached with the drive shaft parallel to the door shaft. It may be necessary to field brace the operator/bracket.

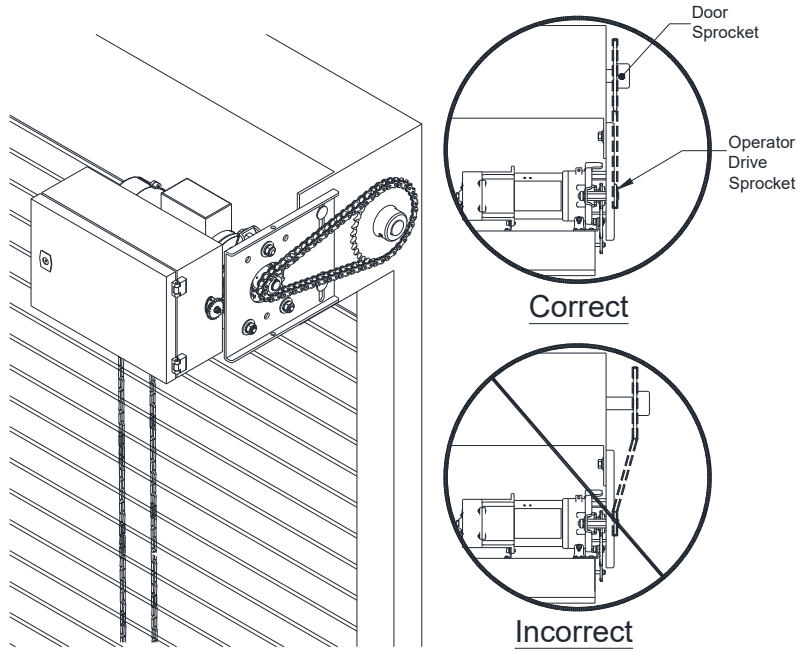

DRIVE CHAIN ADJUSTMENT

NOTE: Use correct type, size and proper length of roller chain.

1. Adjust the drive chain by tilting or move the operator so that there is about 1/4" of slack when the chain is depressed.

Note: The set screw included in the operator may be used for adjustment.

2. Once the drive chain has been tightened and the base leg screws have been set, and then tighten the operator screws.

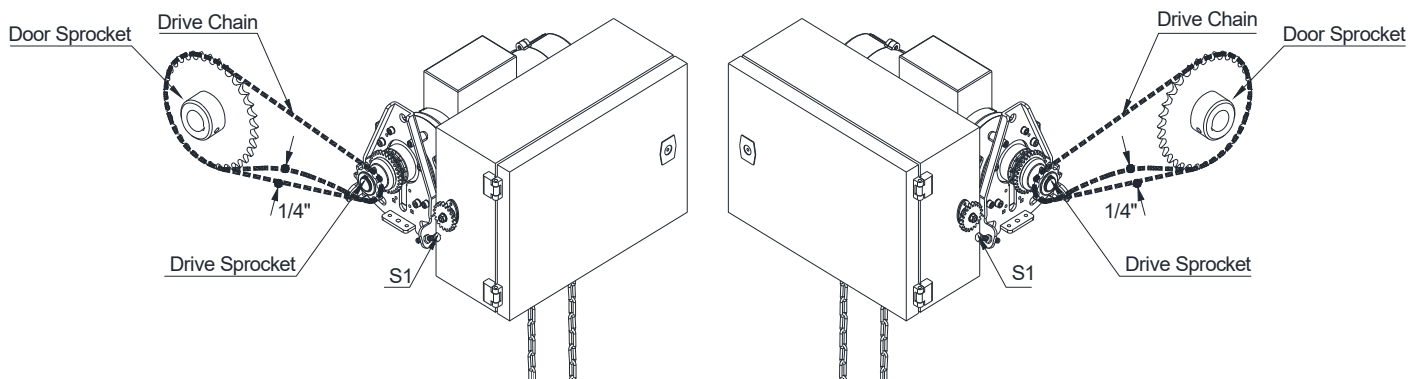

EMERGENCY HAND CHAIN ADJUSTMENT

Cut and reconnect chain with different color link provided.

WARNING: When using hand chain, a dis/engagement cable is not required and should not be used. Use cable only on operators without an auxiliary hand chain or when a pull handle egress device is used in conjunction with an auxiliary hand chain on the MGHC.



The equipped chain hoist is for emergency use only **NOT** for daily operation. Over use will cause damage, which is not covered under the manufacturer's warranty.

WARNING

BRAKE RELEASE LEVER

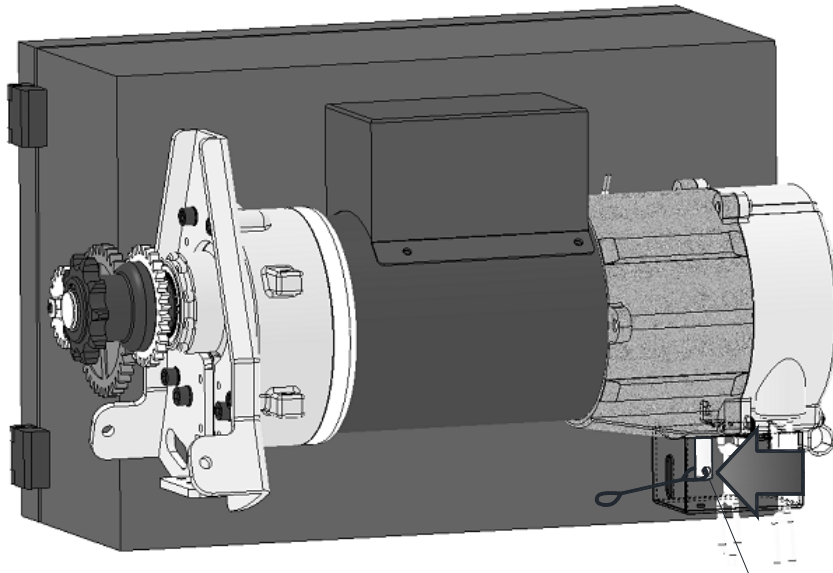

Release Lever



WARNING

Releasing the door operator brake, or loosening or removing any part of the door operator drive system, can cause the door to close and cause death or serious injury. **Do NOT release the brake, or loosen or remove any part of the door operator drive system,** unless the door is closed, or the curtain is secured in the open position to prevent uncoiling.

1. Pressing the brake release lever will release the motor brake and can cause the door to move uncontrolled.
2. Microswitch SW2 is activated when the brake release lever is pressed – see wiring diagrams for details.
3. Open-close-stop controls do not function while the brake release lever is pressed.

NOTE: *A door sprung for emergency egress can open when the brake release lever is pressed.*

LIMIT SWITCH ADJUSTMENT

Make sure the limit cams are positioned between the limit switch actuators before proceeding with adjustments.

1. Open / Remove the control panel cover.
2. Open or close door to determine the moving direction of the limit switch cams.
3. Open or close door to the desired position.



WARNING

Disconnect power before adjusting limit switch cams.

4. While pressing the spring-loaded lever (G), which holds the limit switch cams in place, adjust the limit switch cam (E or F) until the micro switch (C or D) clicking sound is heard.
5. If the limit switch cam cannot be rotated to its desired position, release the lever and move the door away from the desired position, then adjust the limit switch cam to its desired position. It may be necessary to repeat this step until the exact position has been reached.
6. Repeat step 3 and 4 for the opposite position. Adjust close limit cams so that actuator is engaged as door fully seats at the floor.
7. Micro switch (A or B) can be adjusted to accommodate sensing edge cut-off position.

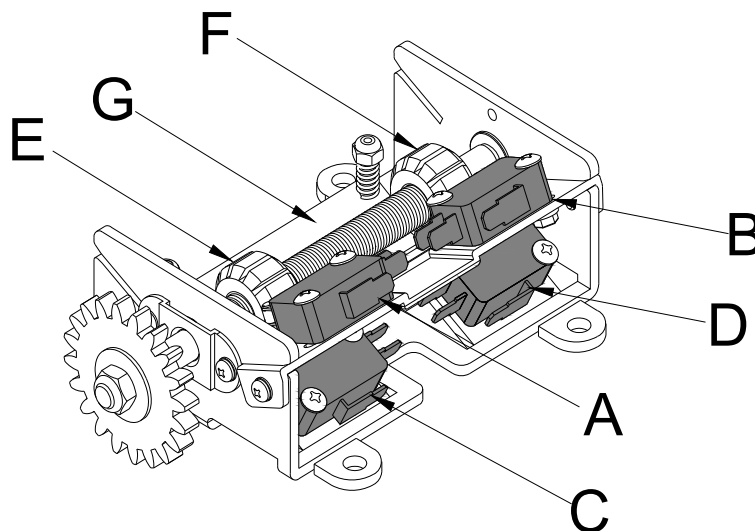

NOTE: **“C”** is usually the opening side and **“D”** is usually the closing side.

WIRING INSTRUCTIONS



Disconnect power at the fuse box before proceeding with any wiring.

WARNING

1. Do not install any wiring or attempt to run this operator without checking the wiring diagram located on the inside of the control box cover.
2. Do not turn on power until you have finished making all power and control wiring connections.
3. Do not run power and control wiring in the same conduit.
4. Any wire connected to the control panel must be protected by conduit or other means to ensure the safety and permanency of the wiring.
5. Use copper wire inside the control panel.
6. A separate circuit of adequate capacity is needed for the operator.
7. The operator must be properly grounded. The ground screw, painted green, is located inside the control panel.
8. For an operator, system, or external device requiring field installed wiring between a Class 2 output of an operator and an external device, the type of wiring shall be R/C (AVLV2/8), AWM, min. 22 AWG, rated 60°C, with VW-1/FT2.



WARNING

Failure to properly ground the operator could result in electric shock and serious injury or death.



WARNING

To avoid damage to door and operator, make all door locks inoperative. Secure lock(s) in the unlocked position, or install electrical interlocks to prevent operation with the lock engaged.

CONTROL WIRING



WARNING

If the door is not visible from the control station, or if any device other than the control station is used to activate the door, an entrapment protection device must be installed on the door. Failure to install an entrapment protection device may result in serious injury or death to person(s) trapped beneath the door.

1. Complete limit switch adjustments before making any sensing edge/non-contact device wiring connections to the operator.

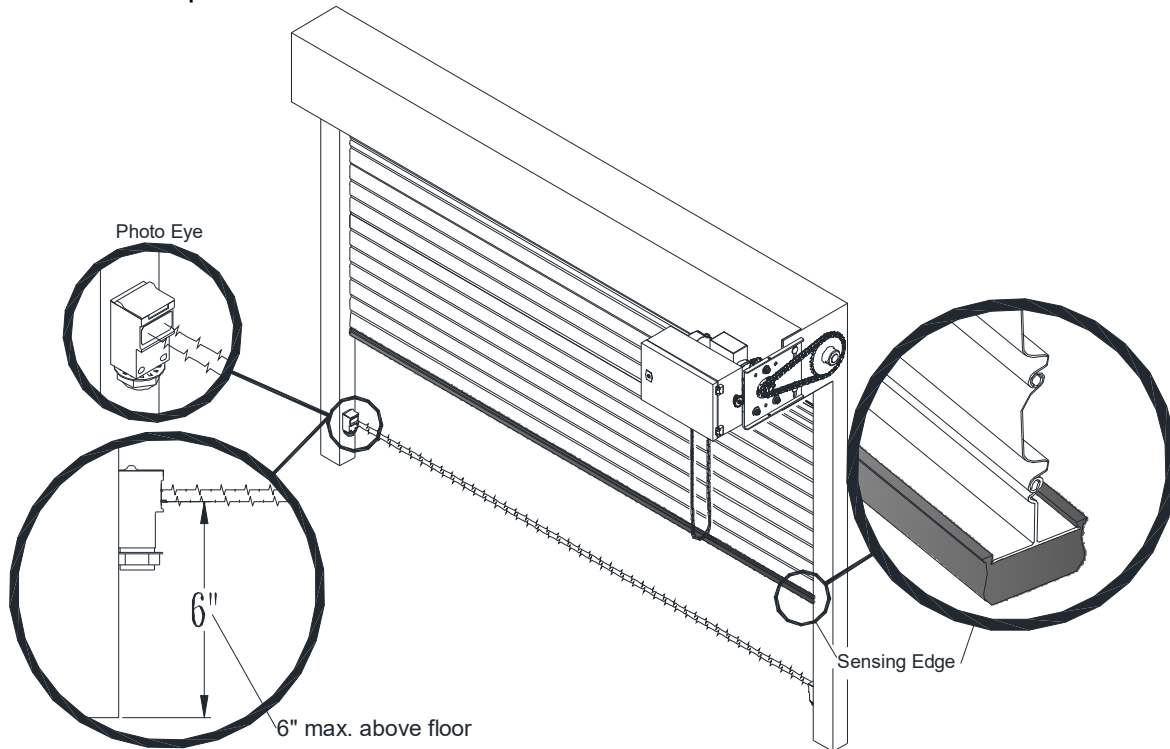

Entrapment Device Options:

Sensing Module	Device Manufacturer	Model
ELR 2-wire resistive sensing edge	Miller Edge Inc. * End of Line resistor type edge must have model number with Suffix T2.	ME110*, ME111*, ME120*, ME123*, ME112*, ME113*, ME116*, ME117*
		MT21*, MU21*, MT22*, MU22*, MC22*, MU33*, MC271*, CPT223*
	ASO	MEL
		RB-G-K10
IR Monitored photo eye	FRABA Inc.	Optical Edge Sensors and Photo Eyes, Models OPTOEYE, OPTOEDGE; Part Nos. OSE-T, OSE-R, OSE-P, OPE. Reflective Photo Eye, Models Ray/RT -1004, -2004
		Martec Access Products Inc.
	Miller Edge Inc.	IG2, MIRM
		RB-D-K10

Note: Please refer to sensing device manufacturer for specific installation and maintenance requirements.



Disconnect power at the fuse box before proceeding with any wiring.

WARNING

2. Locate the control station where the user can clearly see the operation of the door. Mount the enclosed placard adjacent or near the door.



WARNING

Controls shall be far enough from the door, or positioned such that the user is prevented from coming in contact with door while operating the controls.

3. Do not run control wiring in the same conduit as power wiring.
4. Any wire connected to the control panel must be protected by conduit or other means to ensure the safety and permanency of the wiring.



WARNING

Do not use radio controls with your operator unless some type of entrapment protection device has been installed. Failure to do so may result in serious injury or death to person(s) trapped beneath the door.



WARNING

Changing from left hand to right hand or vice versa could result in change of control wiring. Consult factory for details.

5. After installation, be sure that the operator, controls, and sensing edge or other entrapment protection devices have been tested and function properly.

MGHC 380V/400V/415V 3 PHASE 50/60HZ LH (HYBRID BOARD)
(FOR MGHC 7538E)

EMW 501EH L
V1.29

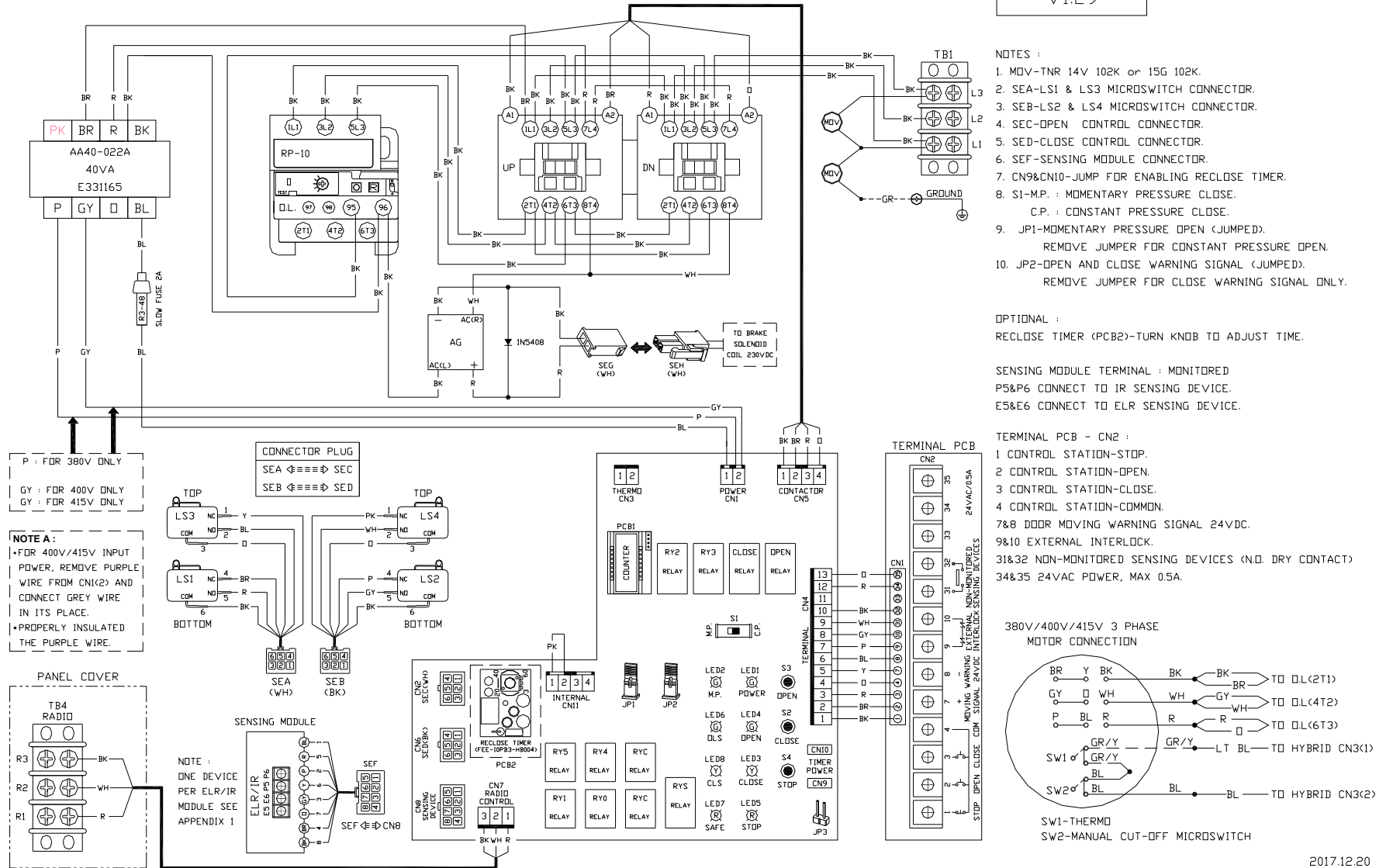

NOTES :

- MOV-TNR 14V 102K or 15G 102K.
- SEA-LS1 & LS3 MICROSWITCH CONNECTOR.
- SEB-LS2 & LS4 MICROSWITCH CONNECTOR.
- SEC-OPEN CONTROL CONNECTOR.
- SED-CLOSE CONTROL CONNECTOR.
- SEF-SENSING MODULE CONNECTOR.
- CN9&CN10-JUMP FOR ENABLING RECLOSE TIMER.
- S1-M.P. : MOMENTARY PRESSURE CLOSE.
C.P. : CONSTANT PRESSURE CLOSE.
- JP1-MOMENTARY PRESSURE OPEN (JUMPED).
REMOVE JUMPER FOR CONSTANT PRESSURE OPEN.
- JP2-OPEN AND CLOSE WARNING SIGNAL (JUMPED).
REMOVE JUMPER FOR CLOSE WARNING SIGNAL ONLY.

OPTIONAL :

RECLOSE TIMER (PCB2)-TURN KNOB TO ADJUST TIME.

SENSING MODULE TERMINAL : MONITORED

P5&P6 CONNECT TO IR SENSING DEVICE.
E5&E6 CONNECT TO ELR SENSING DEVICE.

TERMINAL PCB - CN2 :

- CONTROL STATION-STOP.
- CONTROL STATION-OPEN.
- CONTROL STATION-CLOSE.
- CONTROL STATION-COMMON.
- 7&8 DOOR MOVING WARNING SIGNAL 24VDC.
- 9&10 EXTERNAL INTERLOCK.
- 31&32 NON-MONITORED SENSING DEVICES (N.O. DRY CONTACT)
- 34&35 24VAC POWER, MAX 0.5A.

2017.12.20

MGHC 380V/400V/415V 3 PHASE 50/60HZ RH (HYBRID BOARD)
(FOR MGHC 7538E)

EMW 501EH R
V.1.29

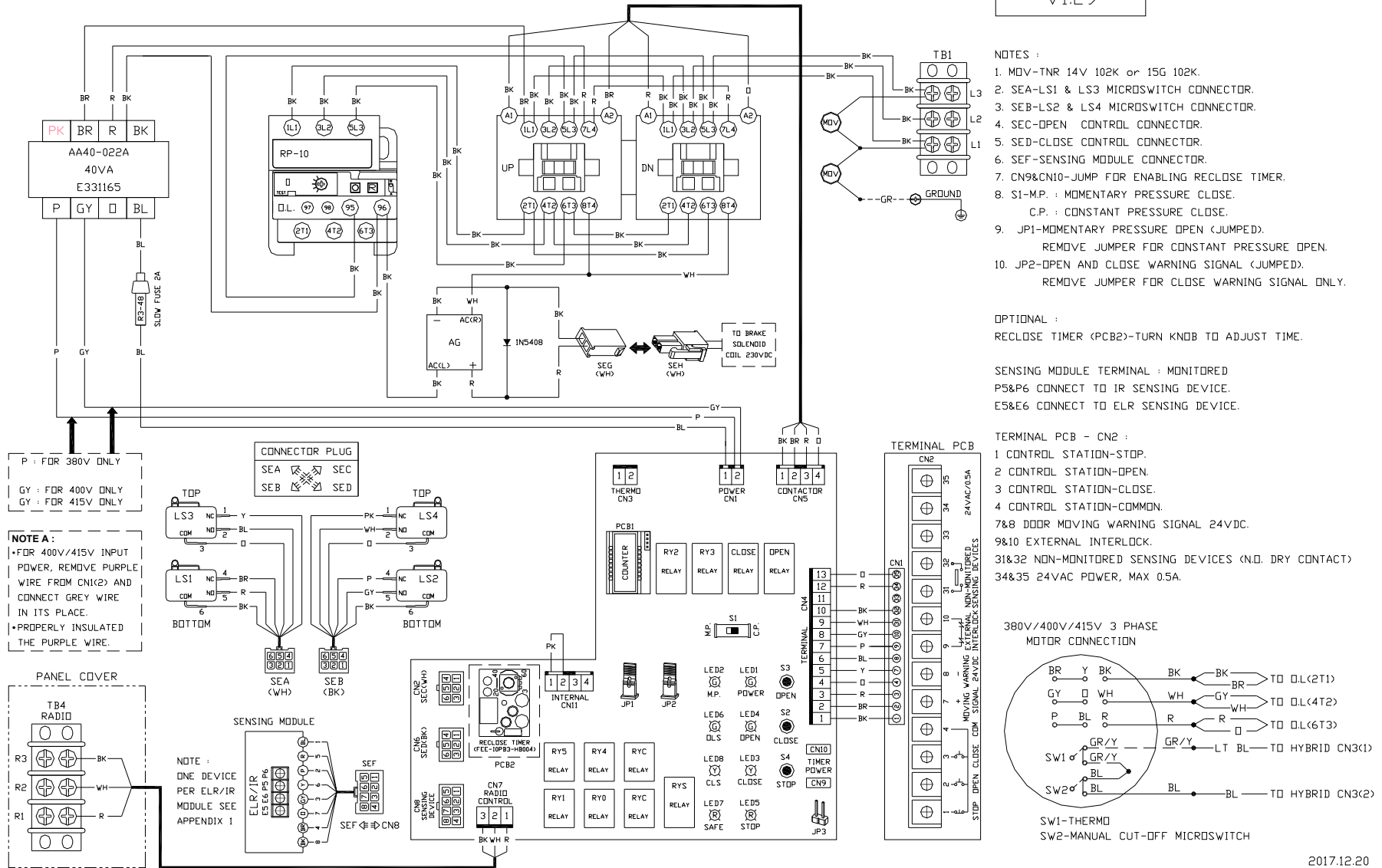

- NOTES :
- MOV-TNR 14V 102K or 15G 102K.
 - SEA-LS1 & LS3 MICROSWITCH CONNECTOR.
 - SEB-LS2 & LS4 MICROSWITCH CONNECTOR.
 - SEC-OPEN CONTROL CONNECTOR.
 - SED-CLOSE CONTROL CONNECTOR.
 - SEF-SENSING MODULE CONNECTOR.
 - CN9&CN10-JUMP FOR ENABLING RECLOSE TIMER.
 - S1-M.P. : MOMENTARY PRESSURE CLOSE.
C.P. : CONSTANT PRESSURE CLOSE.
 - JP1-MOMENTARY PRESSURE OPEN (JUMPED).
REMOVE JUMPER FOR CONSTANT PRESSURE OPEN.
 - JP2-OPEN AND CLOSE WARNING SIGNAL (JUMPED).
REMOVE JUMPER FOR CLOSE WARNING SIGNAL ONLY.

OPTIONAL :
RECLOSE TIMER (PCB2)-TURN KNOB TO ADJUST TIME.

SENSING MODULE TERMINAL : MONITORED
P5&P6 CONNECT TO IR SENSING DEVICE.
E5&E6 CONNECT TO ELR SENSING DEVICE.

- TERMINAL PCB - CN2 :
- CONTROL STATION-STOP.
 - CONTROL STATION-OPEN.
 - CONTROL STATION-CLOSE.
 - CONTROL STATION-COMMON.
- 7&8 DOOR MOVING WARNING SIGNAL 24VDC.
9&10 EXTERNAL INTERLOCK.
31&32 NON-MONITORED SENSING DEVICES (N.O. DRY CONTACT)
34&35 24VAC POWER, MAX 0.5A.

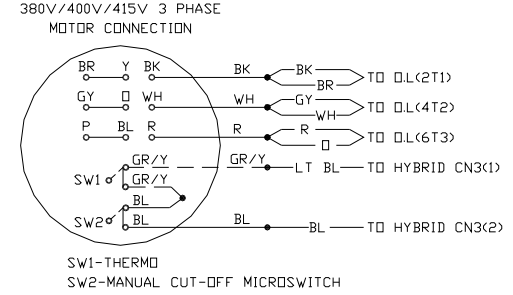

2017.12.20

Reference

MG series terminal connections

1	2	3	4	7	8	9	10	31	32	33	34	35
Control Station				+	-	External Interlock		Non Monitored Sensing Devices (N.O. Dry Contact)			24VAC, 0.5A max.	
Stop	Open	Close	Com	Door moving warning signal 24VDC*		Jump when no external interlock is connected.						

- ❖ A one-second delay on reverse is standard.
- ❖ When the door is closing, pushing the “Open” or “Stop” button will stop the door from moving.
- ❖ When the door is closing, the radio control transmitter can stop and reverse the door at anytime.

* Jump Pin Connections (Hybrid Main Board)

JP1	Factory Default:	Momentary pressure open (Jumped). Remove jumper for constant pressure open.
JP2	Factory Default:	Open and close warning signal (Jumped). Remove jumper for close warning signal only.

Sensing Module connections

(Only 1 Entrapment device can be connected to a single sensing module)

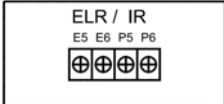
 <p>SENSING MODULE</p> <p>ELR / IR</p> <p>E5 E6 P5 P6</p>	E5 & E6 – Connect with ELR sensing edge
	P5 & P6 – Connect with Photo eyes or IR sensing edge

Control and Accessory connections

Refer to appendix illustrations for connection of:

- ❖ Multiple device adapter for secondary monitored sensing device
- ❖ Reclose timer module
- ❖ Single and multiple control stations
- ❖ External timer defeat switch

IMPORTANT SAFETY INSTRUCTIONS

WARNING –To reduce the risk of severe injury or death:

1. READ AND FOLLOW ALL INSTRUCTIONS.
2. Never let children operate or play with door controls. Keep the remote control (where provided) away from children.
3. Personnel should keep away from a door in motion and keep the moving door in sight until it is completely closed or opened. NO ONE SHOULD CROSS THE PATH OF A MOVING DOOR.
4. Test the door's safety features at least once a month. After adjusting either the force or the limit of travel, retest the door operator's safety features. Failure to adjust the operator properly may cause severe injury or death.
5. For products having a manual release, if possible, use the manual release only when the door is closed. Use caution when using this release when the door is open. Weak or broken springs may cause the door to fall rapidly, causing severe injury or death.
6. KEEP DOORS PROPERLY OPERATING AND BALANCED. See Door Manufacturer's Owner's Manual. An improperly operating or balanced door could cause severe injury or death. Have trained door systems technician make repairs to cables, spring assemblies, and other hardware.
7. **SAVE THESE INSTRUCTIONS.**

OPERATING INSTRUCTIONS

1. If a 3-button control station is used to operate the door, push the “OPEN” button to open the door, push the “CLOSE” button to close the door, push the “STOP” button to stop movement of the door while opening or closing. Removing pressure from the “CLOSE” button will cause the door to stop.
2. If a key switch control station is used to operate the door, turn the key to the “OPEN” position to open the door, turn the key to the “CLOSE” position to close the door, push the “STOP” button to stop movement of the door while opening or closing. Removing pressure from the “CLOSE” key position will cause the door to stop.
3. Door may also be operated by remote devices.

EMERGENCY MANUAL OPERATION

This operator has provisions for manually operating the door in case of emergency or power failure.



WARNING

The equipped chain hoist is for emergency use only NOT for daily operation. Over use will cause damage, which is not covered under the manufacturer’s warranty.

MANUAL RELEASE (Optional)

Pull cable to release brake; then push the door open or pull it closed.

CHAIN HOIST

To operate the hoist:

1. Remove the hand chain from the chain bag.
2. Pull the hand chain to operate the door in the desired direction. (No clutch to engage)

Put the hand chain back into the chain bag, before operating the door again electrically.



WARNING

Turn off power to the operator before manually operating the door.



WARNING

Hand chain must be kept inside chain bag when operating electrically.

MAINTENANCE INSTRUCTIONS

The brake is a self-adjusting brake. It is maintenance free. The brake assembly requires no additional adjustments for its lifetime.

If an entrapment protection device is used, i.e. sensing edge or photoelectric sensors, please consult the manufacturer for maintenance instruction.



Disconnect power supply to the operator before servicing.

WARNING

Check the following items at the intervals listed:

CHECK LIST	DESCRIPTION	EVERY 3 MONTHS	EVERY 6 MONTHS	EVERY 12 MONTHS
Drive Chain	Check for excessive slack. Check & adjust as required Lubricate.	●		
Sprockets	Check set screw tightness	●		
Fasteners	Check & tighten as required		●	
Bearings & Shafts	Check for wear & lubricate	●		

- ❖ Do not lubricate motor. Lubrication could cause damage.
- ❖ Inspect and service whenever a malfunction either door or operator is observed or suspected.
- ❖ Before servicing, always disconnect power supply to the operator.
- ❖ Replace fuses only with those of the same type and rating.
- ❖ All replacement parts must be compatible with those originally provided. Consult manufacturer for replacement parts.



Do not place hands or tools in or near the operator when the power is connected or when testing control or sensing devices. Always disconnect power before servicing or adjusting the operator.

WARNING

U.S. GEAR

Covered under US Pat. #6,900,602, #7,055,283, #7,341,129 and additional patents pending.

APPENDIX 1

Multiple Device Adapter With 2ND ELR/IR Instructions

QST-MGC-HB-ADAPTER-2

Warning: Power OFF When Connecting.

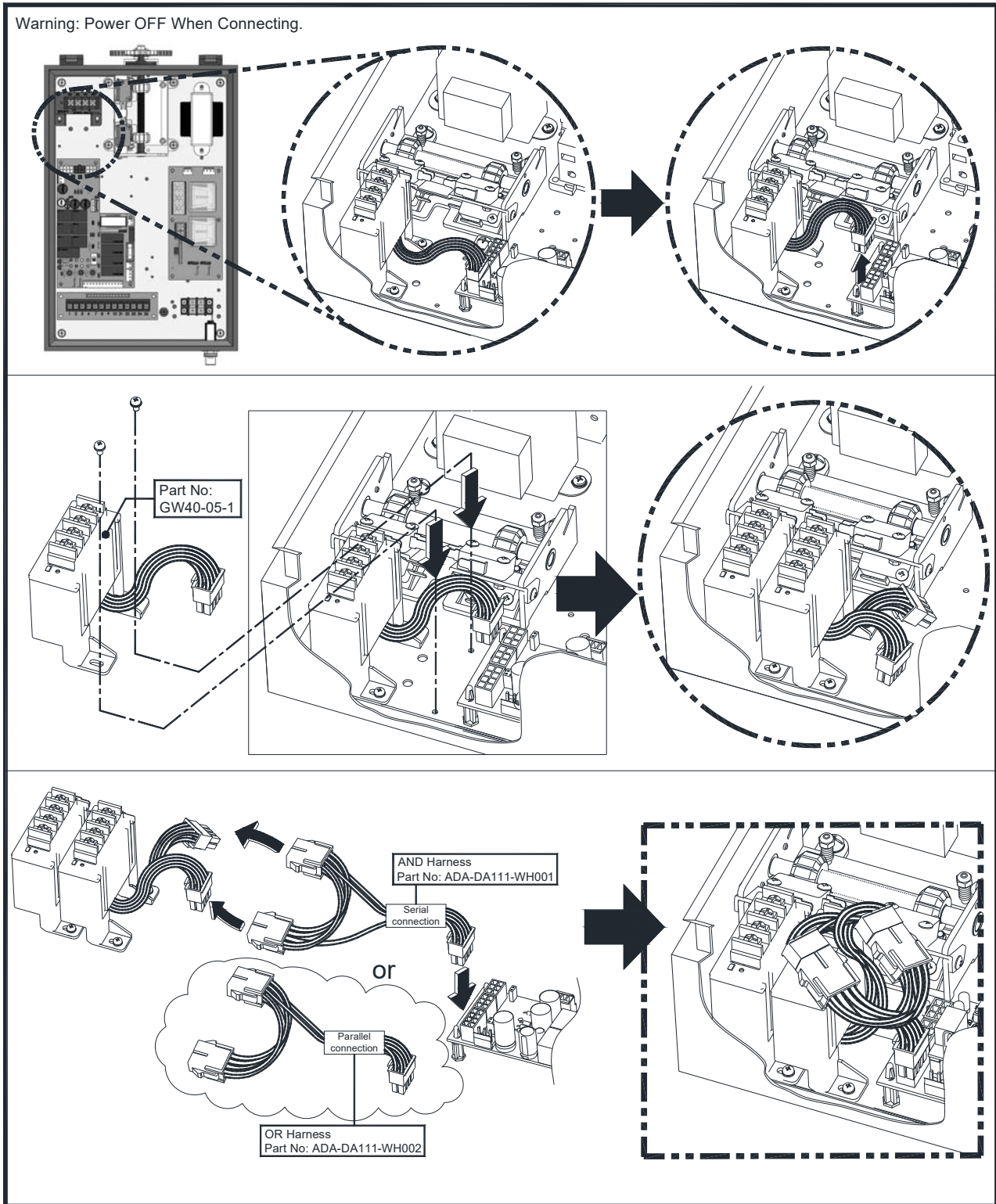

APPENDIX 2

GW40-10

Warning: Power OFF When Connecting.

Reclose Timer Module Instructions

QST-MGC-HB-TIMER-1

Contents:

Plastic Stand-off



X 1

Reclose Timer Module

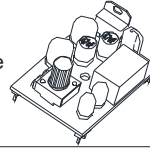

X 1

Jumper Wire



X 1

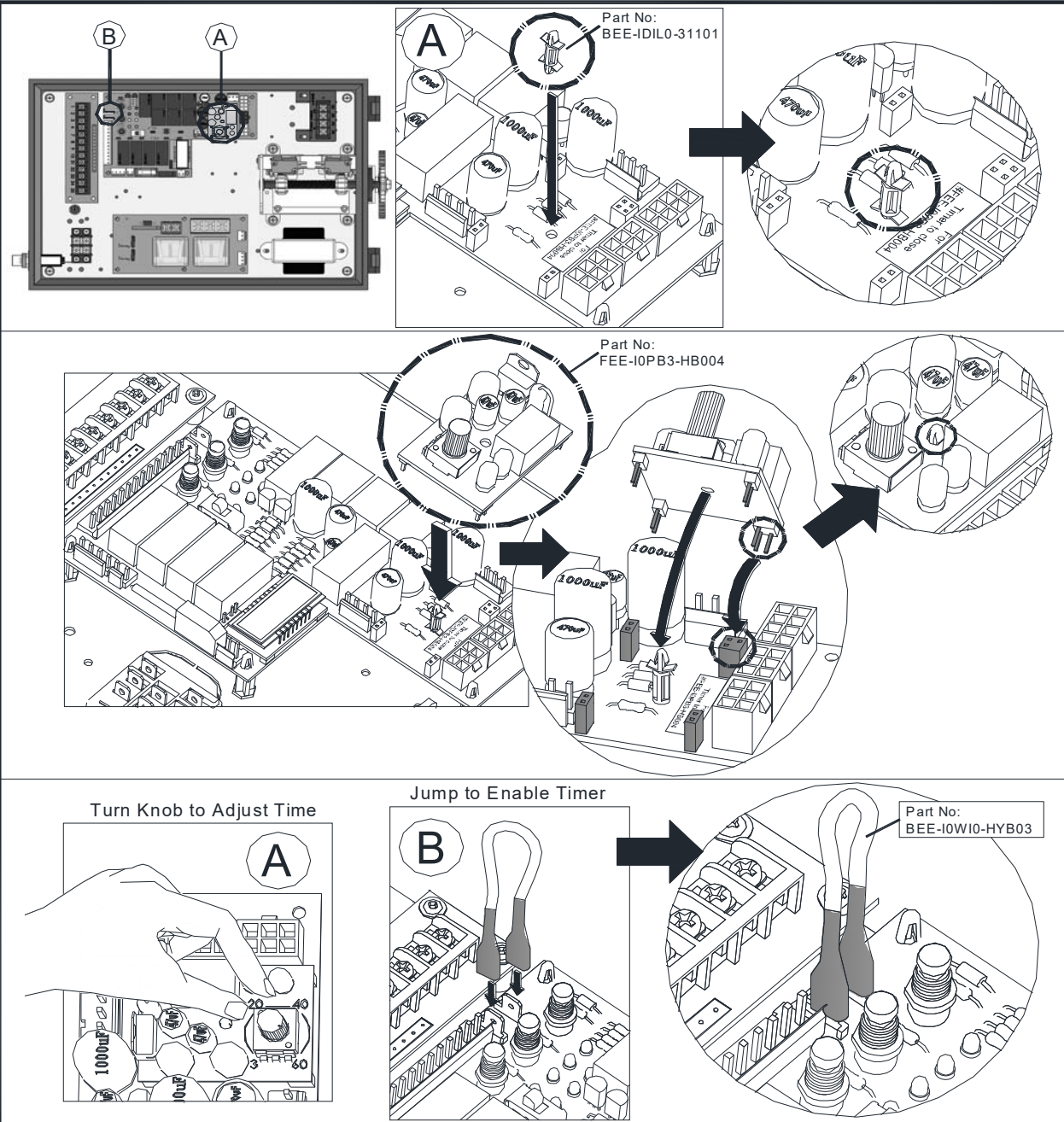

APPENDIX 3

Control Connections Diagrams

CCD-PCB-A01

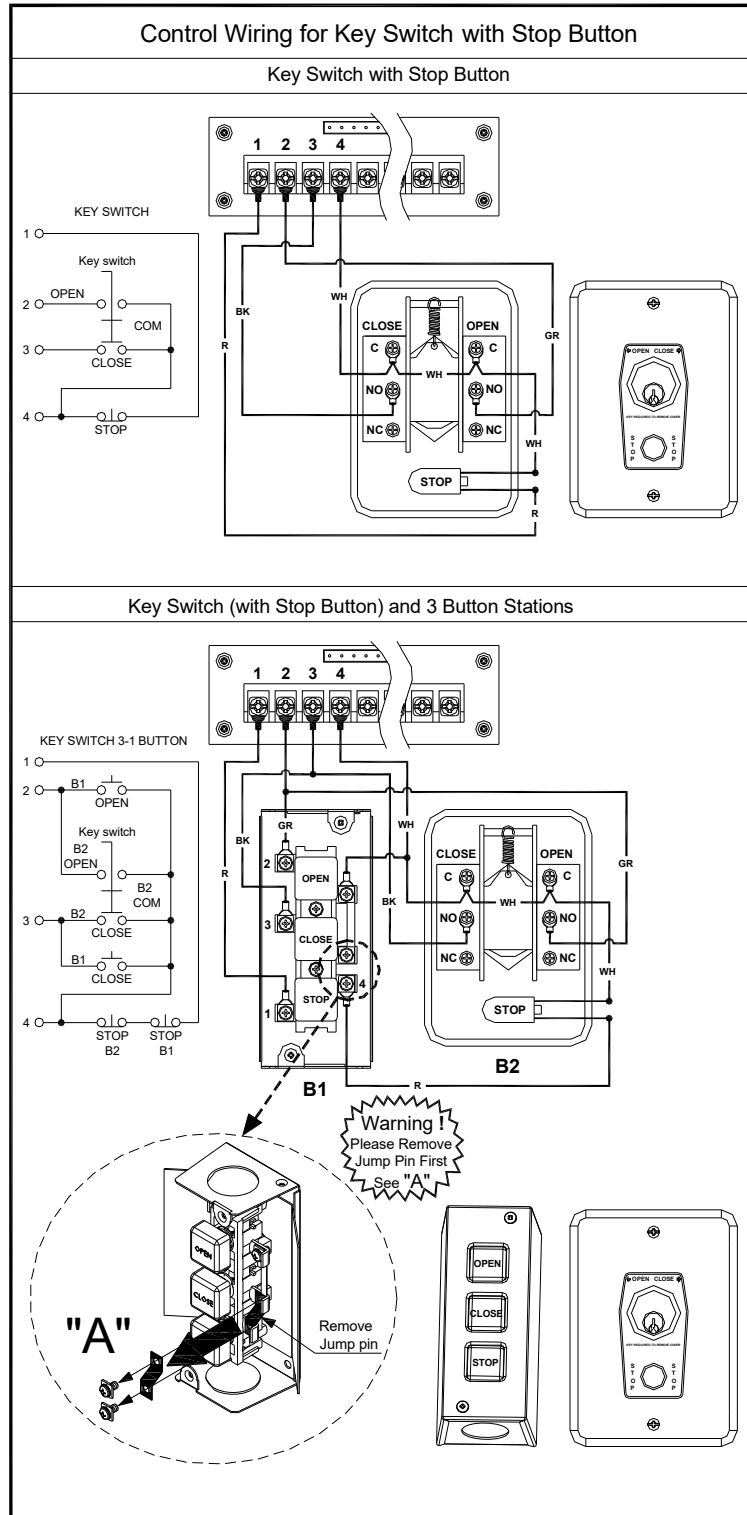
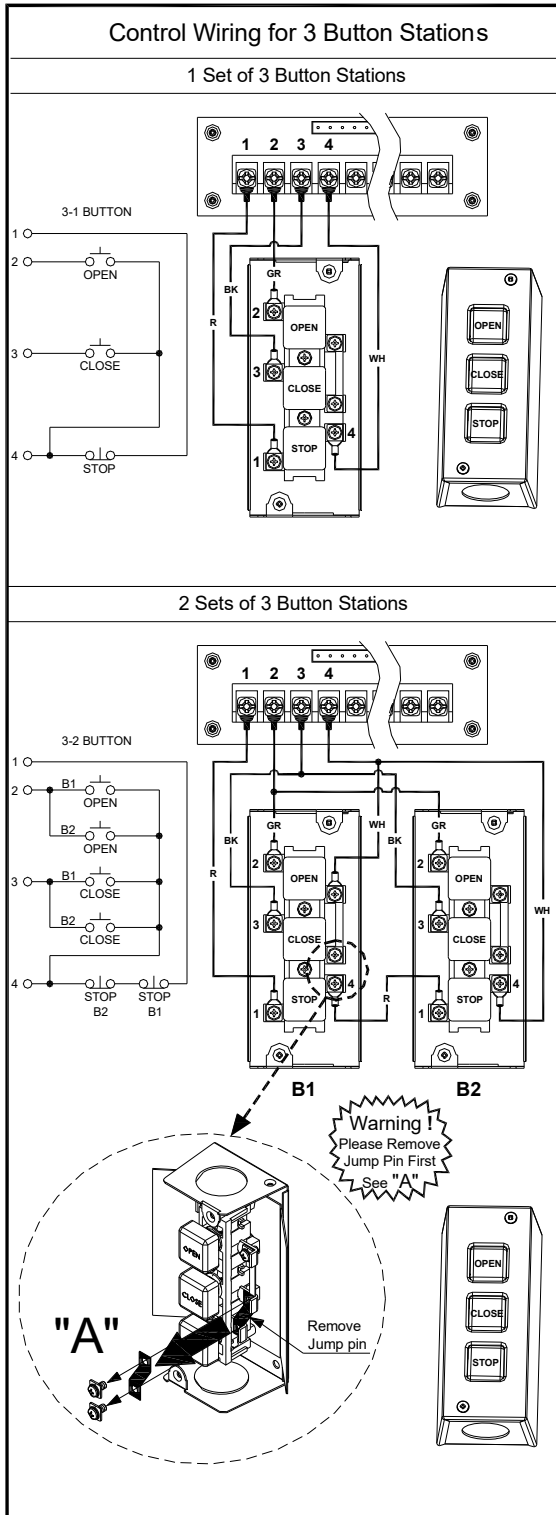

APPENDIX 4

Control Connections Diagrams

CCD-PCB-B02

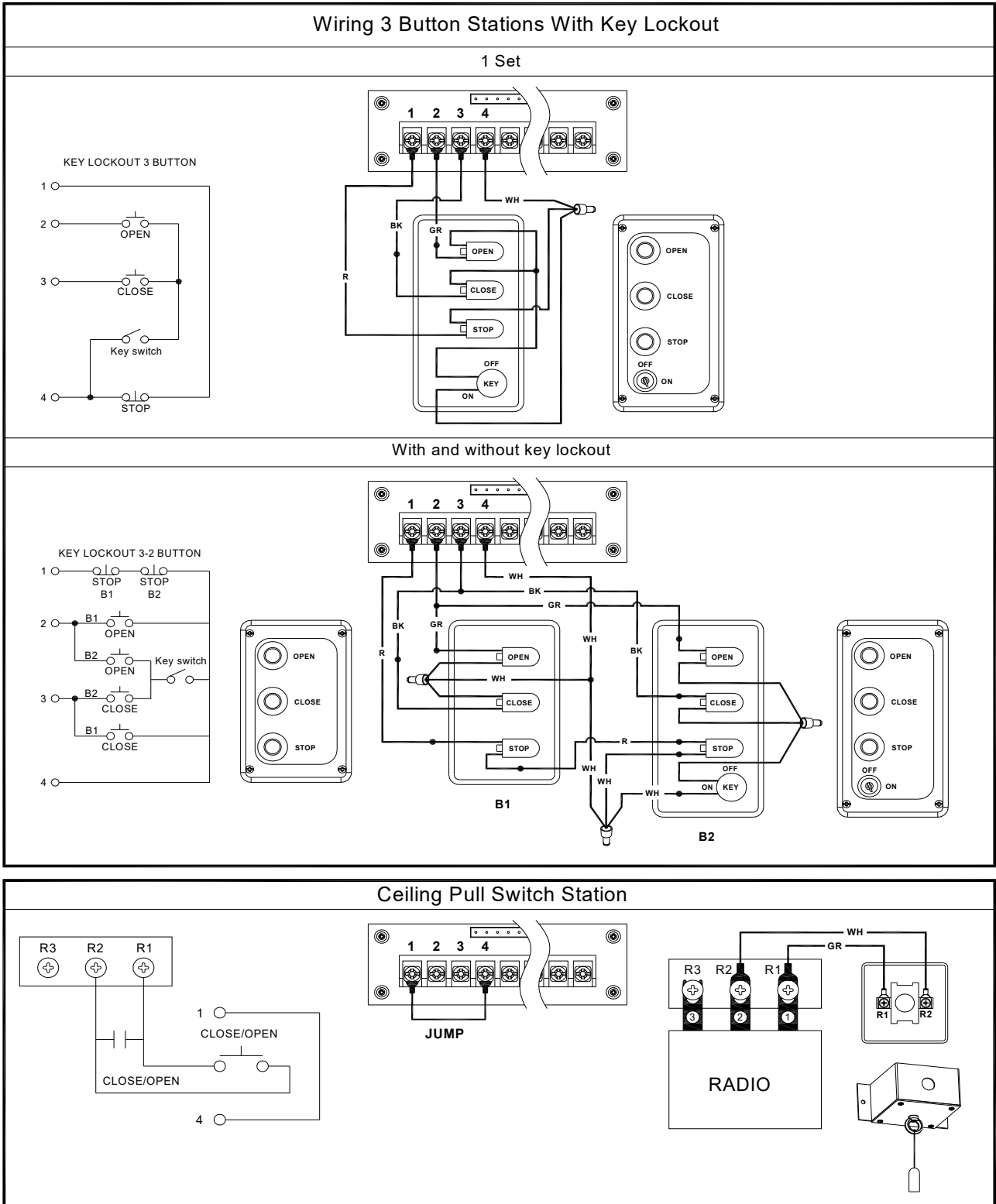

APPENDIX 5

EXTERNAL TIMER DEFEAT SWITCH CONNECTION-HYBRID BOARD

