



INSTALLATION INSTRUCTIONS

AND

OPERATION MANUAL

FS-150EP Series

(v2)

Rolling Fire Door Operators

UL325-2010 Compliant

Restricted Duty Operators

SMART Control

CONTENTS

IMPORTANT INSTALLATION INSTRUCTIONS	2
SPECIFICATIONS	3
TYPES AND SIZES OF DOORS	4
INSTALLATION INSTRUCTIONS	4
OPERATOR MOUNTING POSITIONS	4
OPERATOR MOUNTING	5
DRIVE CHAIN ADJUSTMENT	5
WIRING INSTRUCTIONS	6
CONTROL WIRING	7
ENTRAPMENT DEVICES WIRING	8
INPUT POWER CONNECTIONS	9
LIMIT SWITCH ADJUSTMENT	10
CONTROL SETTINGS	11
CONTROL FUNCTION	11
AUXILIARY FUNCTION	12
TIMER INSTRUCTION	13
LCD DISPLAY INSTRUCTION	14
LIGHT INDICATION	15
SOUND WARNINGS	15
WIRING DIAGRAMS	16
IMPORTANT SAFETY INSTRUCTIONS	26
FUSIBLE LINK CONNECTIONS	27
TESTING	28
PUSH BUTTON STATION TESTING	28
MAINTENANCE INSTRUCTIONS	29
APPENDIX 1: Multiple Sensing Devices Connection Instruction	30
APPENDIX 2: Control Connections Diagrams	31
APPENDIX 3: Control Connections Diagrams	32
APPENDIX 4: External Timer Defeat Switch Connection	33
APPENDIX 5: Wiring Change Instruction from 230V to 208V 3 Phase Operator	34

IMPORTANT INSTALLATION INSTRUCTIONS

WARNING – To reduce the risk of death or serious injury to persons:

1. READ AND FOLLOW ALL INSTALLATION INSTRUCTIONS.

WARNING! – Components under **extreme spring tension** can cause death or serious injury.

2. Install only on a properly operating and balanced door. A door that is operating improperly could cause death or serious injury. Trained door systems technicians make all necessary adjustments and repairs to the door before installing the operator.

Note: Fire door spring tension must be adjusted per the manufacturer's installation instructions to allow for automatic closing during a drop test, fusible link/alarm activation and/or power failure (Power failure condition only applies to operators capable of fail-safe closing).

3. Remove all pull ropes.
4. Unless the door operator includes an internal lock sensing system, or external electrical interlocks are installed, remove or make all door locks inoperative, or secure locks in the unlocked position to prevent operation with the locks engaged.
5. Install the door operator at least 8 feet or more above the floor if the operator has exposed moving parts. If the operator must be mounted less 8 ft (2.44 m) above the floor, then exposed moving parts must be protected by covers or guarding. Contact the manufacturer.
6. Do not connect the door operator to the source of power until instructed to do so.
7. Locate the control station (open-close-stop push button, key station, or the like): (a) within sight of the door, (b) at a minimum height of 5 feet above floors, landings, steps, or any other adjacent walking surface and (c) away from all moving parts of the door.
8. Install the Entrapment Warning Placard next to the control station in a prominent location.
9. Make sure the available power supply to be connected to the operator is of the same voltage, frequency, phase and wattage as indicated on the nameplate of the operator.
10. Read and understand the wiring diagram of the operator and the control station and any other equipment to be connected to the operator.
11. Always disconnect power whenever installing or servicing the door operator or door.
12. All wiring must be permanent and comply with National Electrical Code (NEC) and local code requirements.
13. Any change in mounting position may result in a change of operator rotation and consequently in a change of control functions. Consult factory for any changes.
14. For products having a manual release, instruct the end user on the operation of the manual release.

SPECIFICATIONS

MOTOR	
Duty Cycle:	Restricted cycle duty (30 cycles per hour)
Horsepower:	1-1/2 hp
Speed:	1700 RPM
Voltage:	115, 230 – 1 phase 208/230, 460, 575 – 3 phase 230 volt 3 phase motor is suitable for use with 208 volts (see <i>Wiring Diagrams and Appendix 5 for wiring change instruction</i>)
Current:	See motor nameplate
ELECTRICAL	
Transformer:	24VAC
Wiring Type:	Momentary pressure open, stop, constant pressure close (provided standard), with provision for momentary pressure close*
Limit Adjustment:	Linear driven, fully adjustable screw type cams.
MECHANICAL	
Drive Reduction:	82:1
Output Shaft Speed:	21 RPM
Door Speed:	6 - 8" per sec. average (typical)
Brake:	Solenoid actuated brake
ENTRAPMENT PROTECTION	
Sensing Edge*:	(Optional) Sensing device attached to the bottom edge of the door.
Non-Contact Device*:	(Optional) Photo eye device.
* Per the requirements of UL Standard 325, the door operator is setup for constant pressure to close the door. As an alternative, the door may be provided with a monitored entrapment protection device that will reverse the door upon contact with or detection of an obstruction during closing. Adding an entrapment device would enable momentary close operation.	

Notes:

1. Non-contact device (photo eye) can be used on doors up to 45 ft. wide (or maximum rated range of device if less than 45 ft.). Use a sensing edge to provide entrapment protection on doors over 45 ft. wide.
2. Sensing edge can be used on all doors.

TYPES AND SIZES OF DOORS

Consult factory for details.

INSTALLATION INSTRUCTIONS

OPERATOR MOUNTING POSITIONS

NOTE: Any change in mounting position may result in a change of operator rotation and consequently in a change of control functions. Consult factory for any changes. (LS and RA mounting positions are LH operators, RS and LA positions are RH operators)

Consult factory for changes in mounting positions.

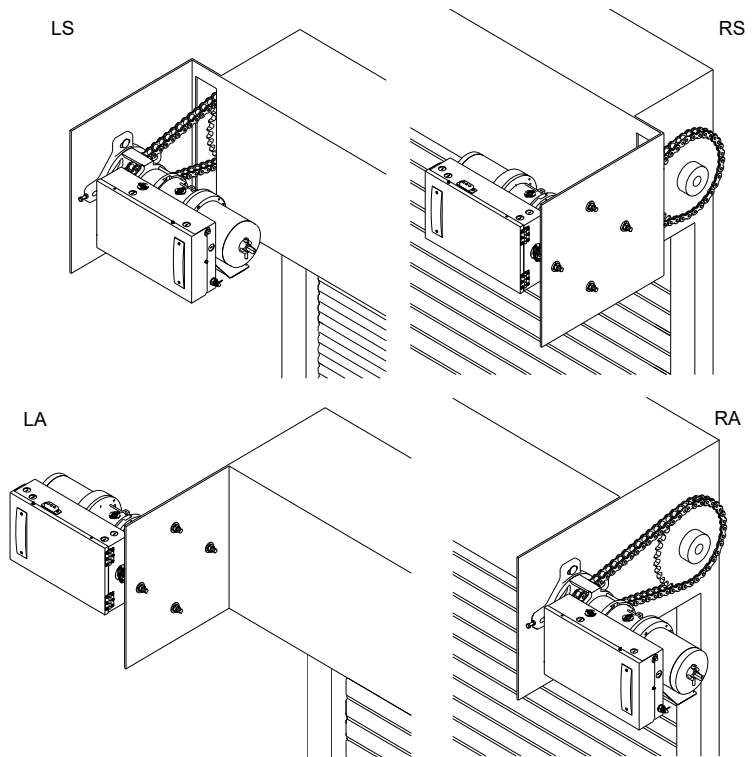

OPERATOR MOUNTING

1. Before the operator is installed, verify that the door is properly operating and balanced.
2. Make sure the layout of the mounting holes on the bracket is correct.
3. Mount the operator base to the mounting plate.
4. When the operator assembly is attached to the door bracket, be sure the door driven sprocket is properly aligned with the operator drive sprocket before securing the driven sprocket to the shaft.
5. The shelf or bracket must provide adequate support for the operator. Prevent play between the operator and the door shaft. The operator must be securely attached with the drive shaft parallel to the door shaft. It may be necessary to field brace the operator/bracket.

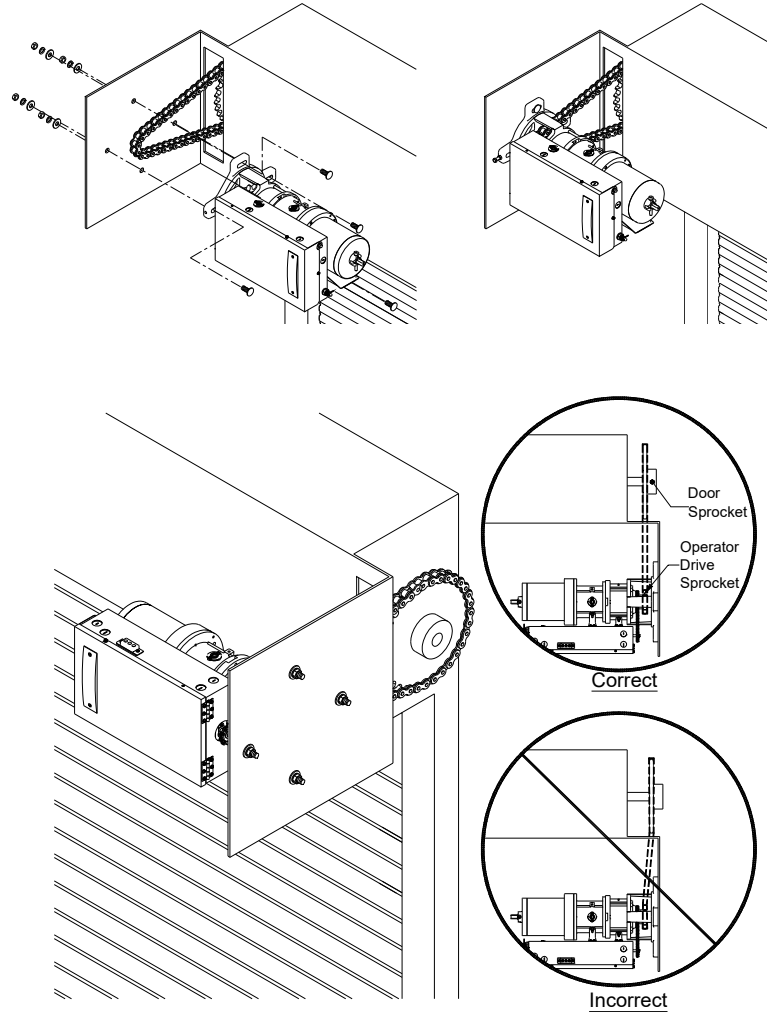

DRIVE CHAIN ADJUSTMENT

NOTE: Use correct type, size and proper length of roller chain.

1. Adjust the drive chain by tilting or move the operator so that there is about 1/4" of slack when the chain is depressed.

Note: The set screw included in the operator may be used for adjustment.
(See figure - T1, T2 location)

2. Once the drive chain has been tightened and the base leg screws have been set, and then tighten the operator set screws.

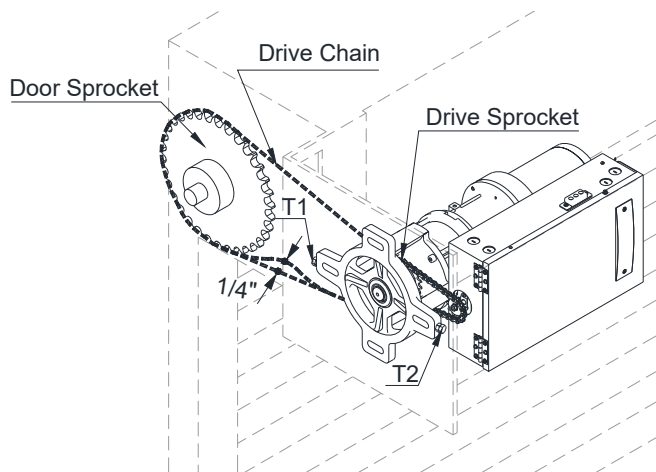

WIRING INSTRUCTIONS

WARNING

Disconnect power at the fuse box before proceeding with any wiring.

1. Do not install any wiring or attempt to run this operator without checking the wiring diagram located on the inside of the control box cover.
2. Do not turn on power until you have finished making all power and control wiring connections.
3. Do not run power and control wiring in the same conduit.
4. Any wire connected to the control panel must be protected by conduit or other means to ensure the safety and permanency of the wiring.
5. Use copper wire inside the control panel.
6. A separate fuse line of adequate capacity is needed for the operator.
7. The operator must be properly grounded. The ground screw, painted green, is located inside the control panel.
8. For an operator, system, or external device requiring field installed wiring between a Class 2 output of an operator and an external device, the type of wiring shall be R/C (AVLV2/8), AWM, min. 22 AWG, rated 60°C, with VW-1/FT2.

WARNING

- **Failure to properly ground the operator could result in electric shock and serious injury or death.**
- **Unless the operator includes an internal lock sensing system, or external electrical interlocks are installed, remove or make all door locks inoperative, or secure locks in the unlocked position. Failure to disable the locks could result in damage to the door or operator.**

CONTROL WIRING

⚠ WARNING

Disconnect power at the fuse box before proceeding with any wiring.

1. Locate the control station where the user can clearly see the operation of the door. Mount the enclosed placard adjacent or near the door.



⚠ WARNING

Controls shall be located far enough away from the door, or positioned such that the user is prevented from coming in contact with the door, while operating the controls.

2. Do not run control wiring in the same conduit as power wiring.
3. Any wire connected to the control panel must be protected by conduit or other means to ensure the safety and permanency of the wiring.

⚠ WARNING

- Do not use radio controls with your operator unless some type of entrapment protection device has been installed. Failure to do so may result in serious injury or death to person(s) trapped beneath the door.
- Changing from left hand to right hand or vice versa could result in change of control wiring. Consult factory for details.

ENTRAPMENT DEVICES WIRING

⚠ WARNING

If the door is not visible from the control station, or if any device other than the control station is used to activate the door, an entrapment protection device must be installed on the door. Failure to install an entrapment protection device may result in serious injury or death to person(s) trapped beneath the door.

1. Complete limit switch adjustments before making any sensing edge/non-contact device wiring connections to the operator.

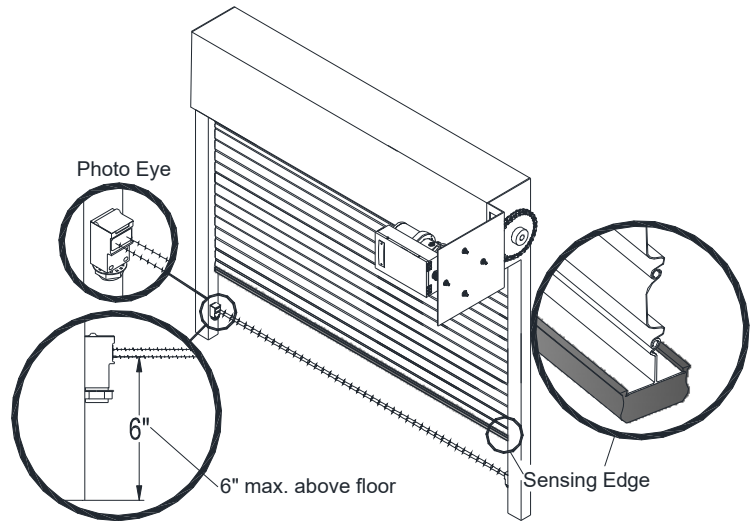

Entrapment Device Options:

Sensing Module	Device Manufacturer	Model
ELR 2-wire resistive sensing edge	Miller Edge Inc. * End of Line resistor type edge must have model number with Suffix T2.	ME110*, ME111*, ME120*, ME123*, ME112*, ME113*, ME116*, ME117*
		MT21*, MU21*, MT22*, MU22*, MC22*, MU33*, MC271*, CPT223*
		MEL-TXYY, MEL-RXYY
	ASO	RB-G-K10
IR Monitored photo eye	FRABA Inc.	GE225, GE125, GE245, GE F45, GE F50, GE F56, GE F65, GE F85, GE F115
	Martec Access Products Inc.	Optical Edge Sensors and Photo Eyes, Models OPTOEDGE, OPTOEYE, OSE, OPE, OSE-P, OSE-R, OSE-T, RAY-N Reflective Photo Eye, Models Ray/RT -1004, -2004
	Miller Edge Inc.	1266
		IG2, MIRM
		RB-D-K10

Note: Please refer to sensing device manufacturer for specific installation and maintenance requirements.

2. After installation, be sure that the operator, controls, and sensing edge or other entrapment protection devices have been tested and function properly.

INPUT POWER CONNECTIONS

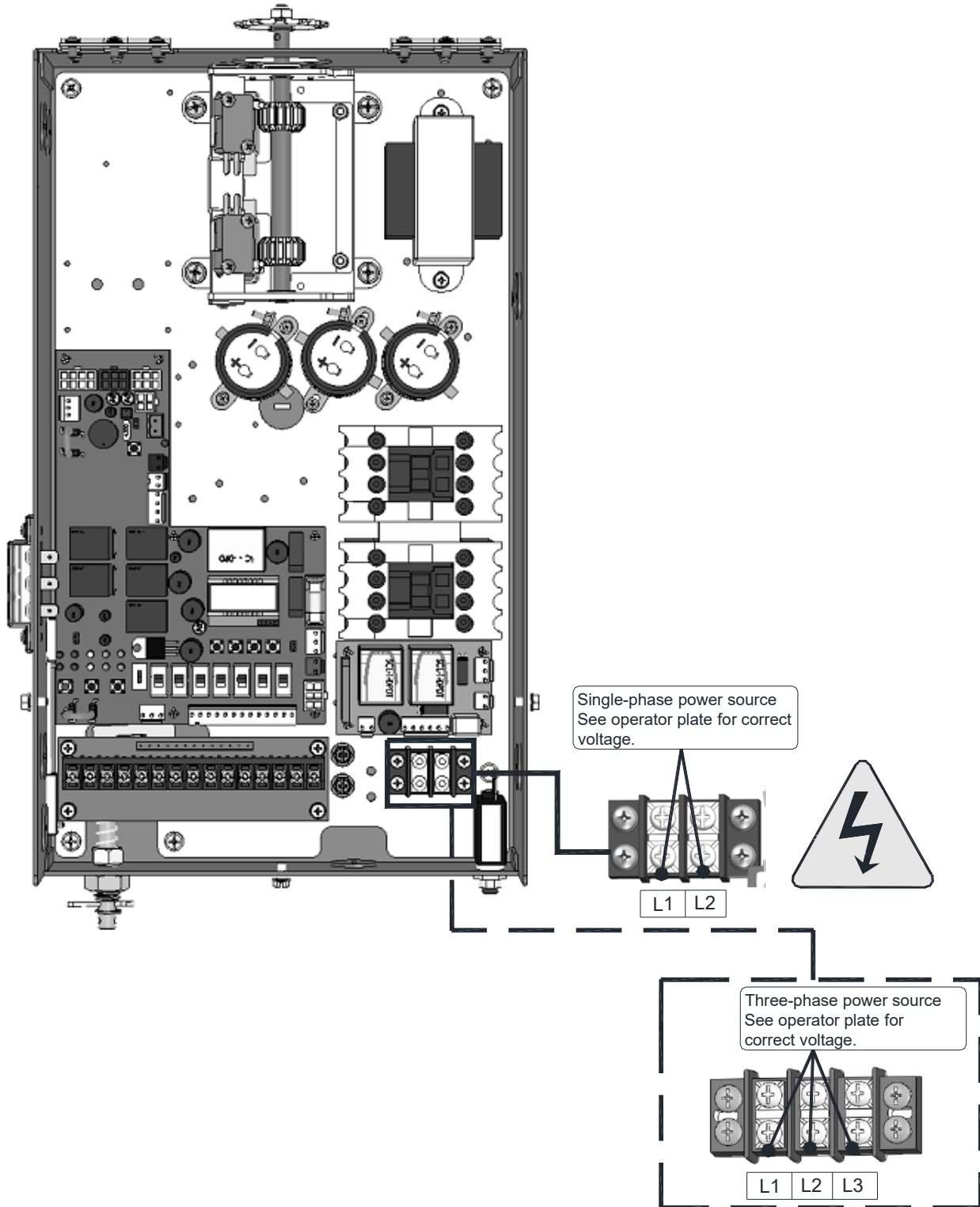

LIMIT SWITCH ADJUSTMENT

Make sure the limit cams are positioned between the limit switch actuators before proceeding with adjustments.

1. Open / Remove the control panel cover.
2. Open or close door to determine the moving direction of the limit switch cams.
3. Open or close door to the desired position.

⚠ WARNING

Disconnect power before adjusting limit switch cams.

4. While pressing the spring-loaded lever (G), which holds the limit switch cams in place, adjust the limit switch cam (E or F) until the micro switch (C or D) clicking sound is heard.
5. If the limit switch cam cannot be rotated to its desired position, release the lever and move the door away from the desired position, then adjust the limit switch cam to its desired position. It may be necessary to repeat this step until the exact position has been reached.
6. Repeat step 3 and 4 for the opposite position. Adjust close limit cams so that actuator is engaged as door fully seats at the floor.
7. Micro switch (A or B) can be adjusted to accommodate sensing edge cut-off position.

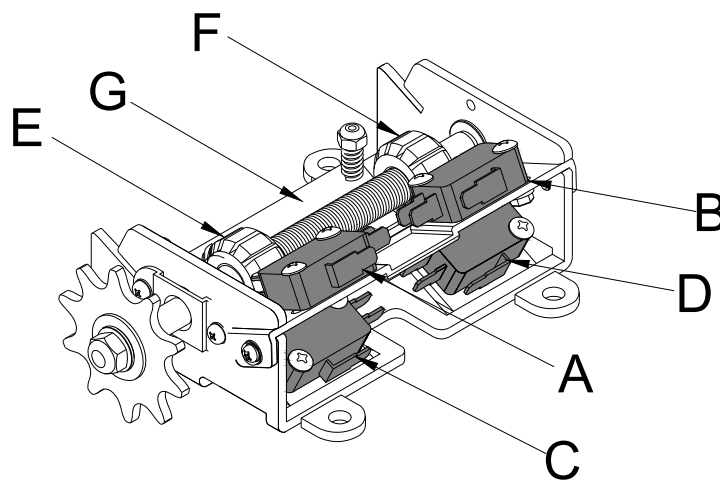

NOTE: "C" is usually the open limit switch and "D" is usually the close limit switch.

CONTROL SETTINGS

CONTROL FUNCTION

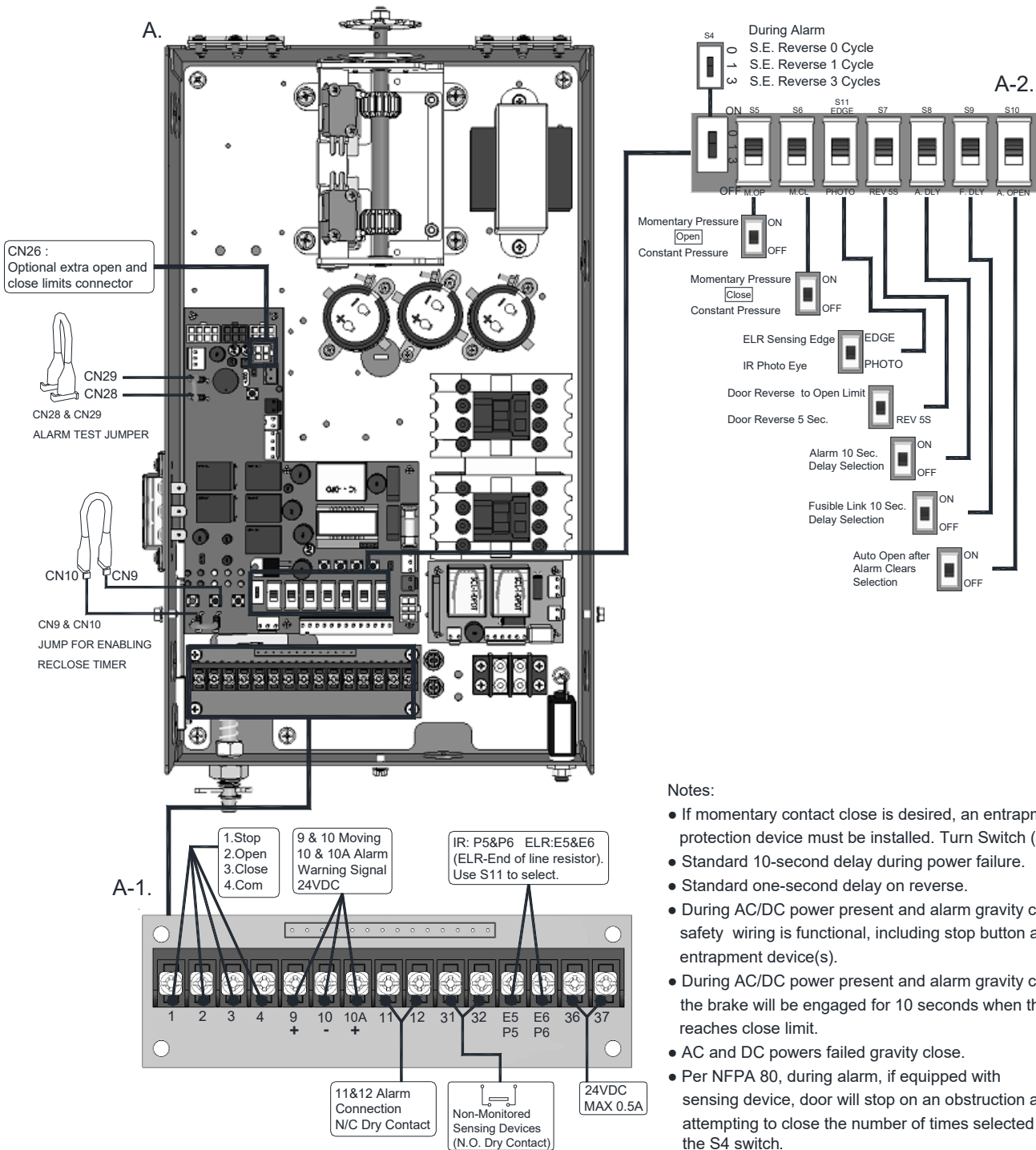

Notes:

- If momentary contact close is desired, an entrapment protection device must be installed. Turn Switch (S6) to **ON**.
- Standard 10-second delay during power failure.
- Standard one-second delay on reverse.
- During AC/DC power present and alarm gravity closing, safety wiring is functional, including stop button and entrapment device(s).
- During AC/DC power present and alarm gravity closing, the brake will be engaged for 10 seconds when the door reaches close limit.
- AC and DC powers failed gravity close.
- Per NFPA 80, during alarm, if equipped with sensing device, door will stop on an obstruction after attempting to close the number of times selected on the S4 switch.

AUXILIARY FUNCTION

B-2. Radio control

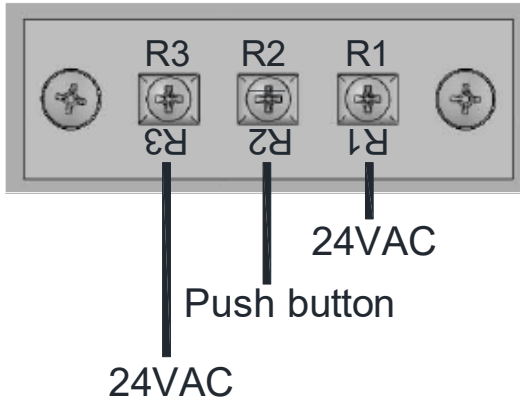

B-1.

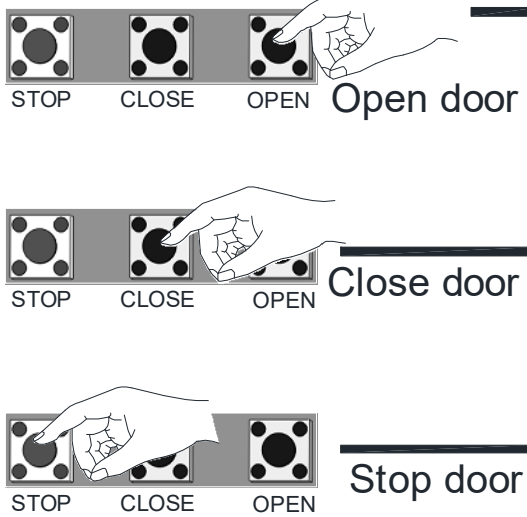

B.

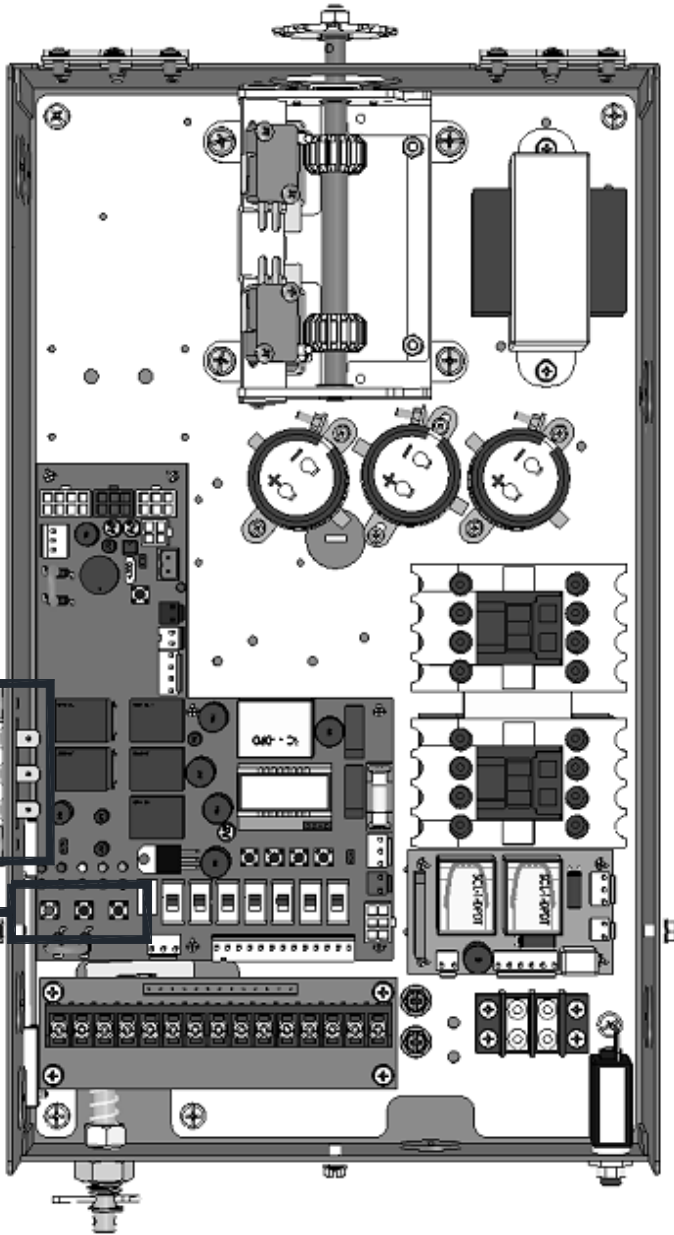

TIMER INSTRUCTION

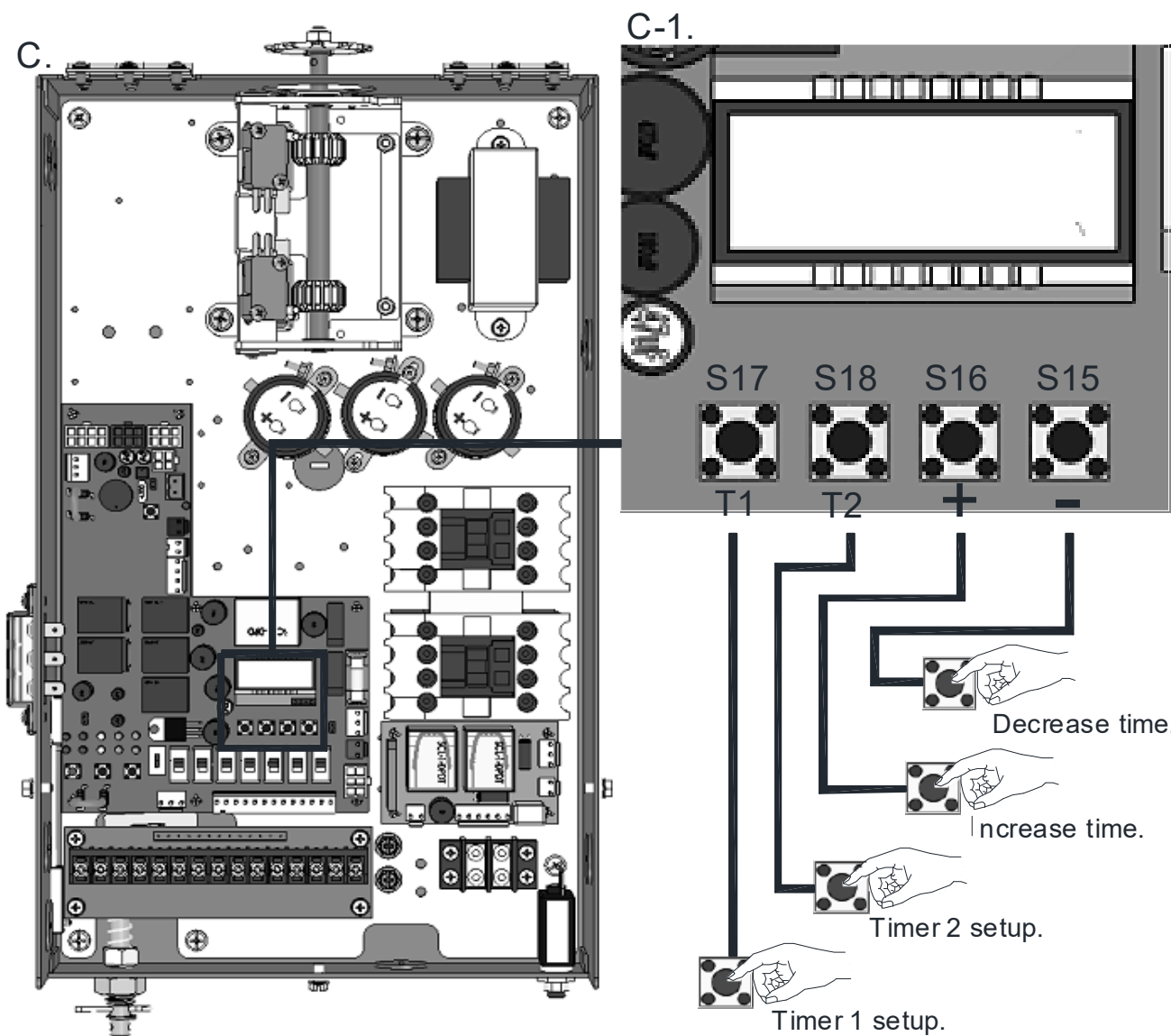





1. Time 1 – Mid-open timer : Timer starts counting when door leaves close limit. Door stops after opening for set time. Pressing open again at mid-open position will cause door to open limit.

Time 2 – Close timer : Timer is active when door stops and is not at close limit.



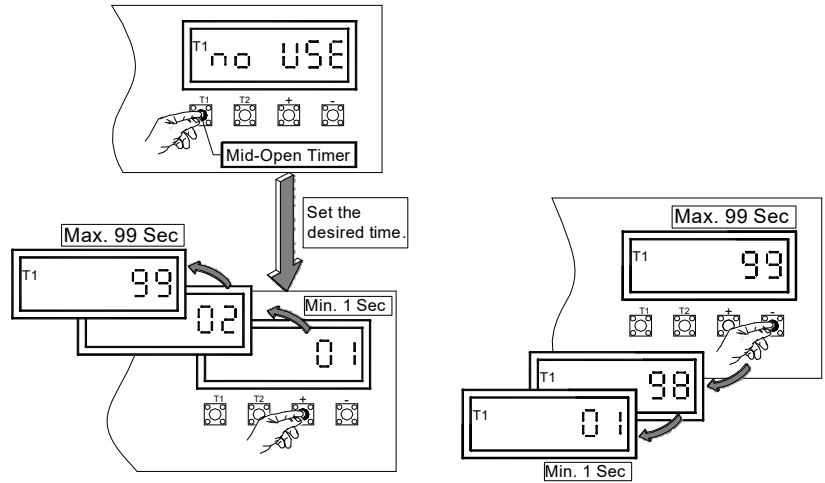

2. Standard Mode: Cycle counter

3. To Set Timer 1 (Mid-open Timer)

- Press  and hold for 5 seconds. Display will flash.
- Use  and  to increase or to decrease time.
- Press  to save setting. Without pressing, no adjustment is saved.



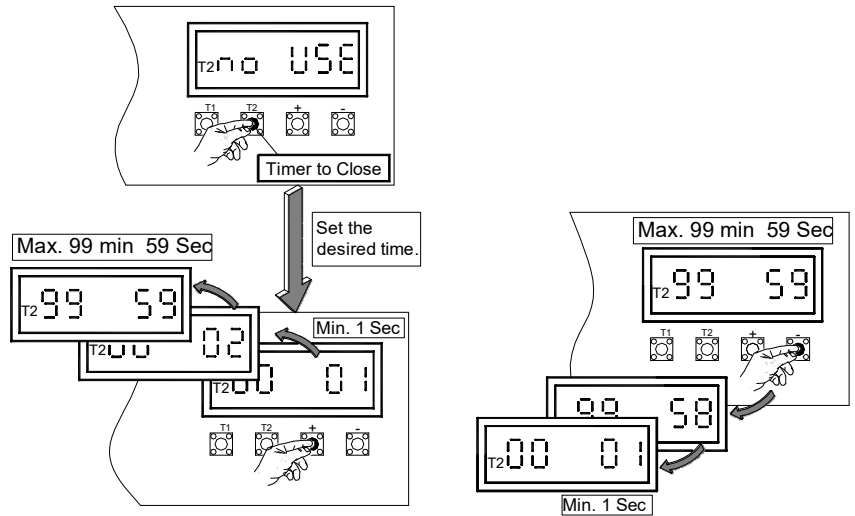

4. To Set Timer 2 (Reclose Timer)

- Press  and hold for 5 seconds. Display will flash.
- Use  and  to increase or to decrease time.
- Press  to save setting. Without pressing, no adjustment is saved.

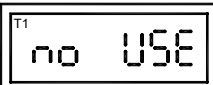
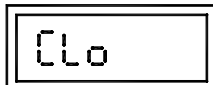
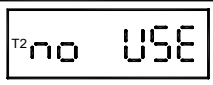

LCD DISPLAY INSTRUCTION

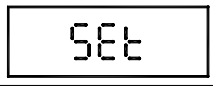
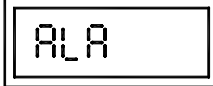
Display	Status	Display	Status
	T1 setting		Door closing
	T2 setting		Door opening
	T1 or T2 setting completed		Alarm condition

LIGHT INDICATION

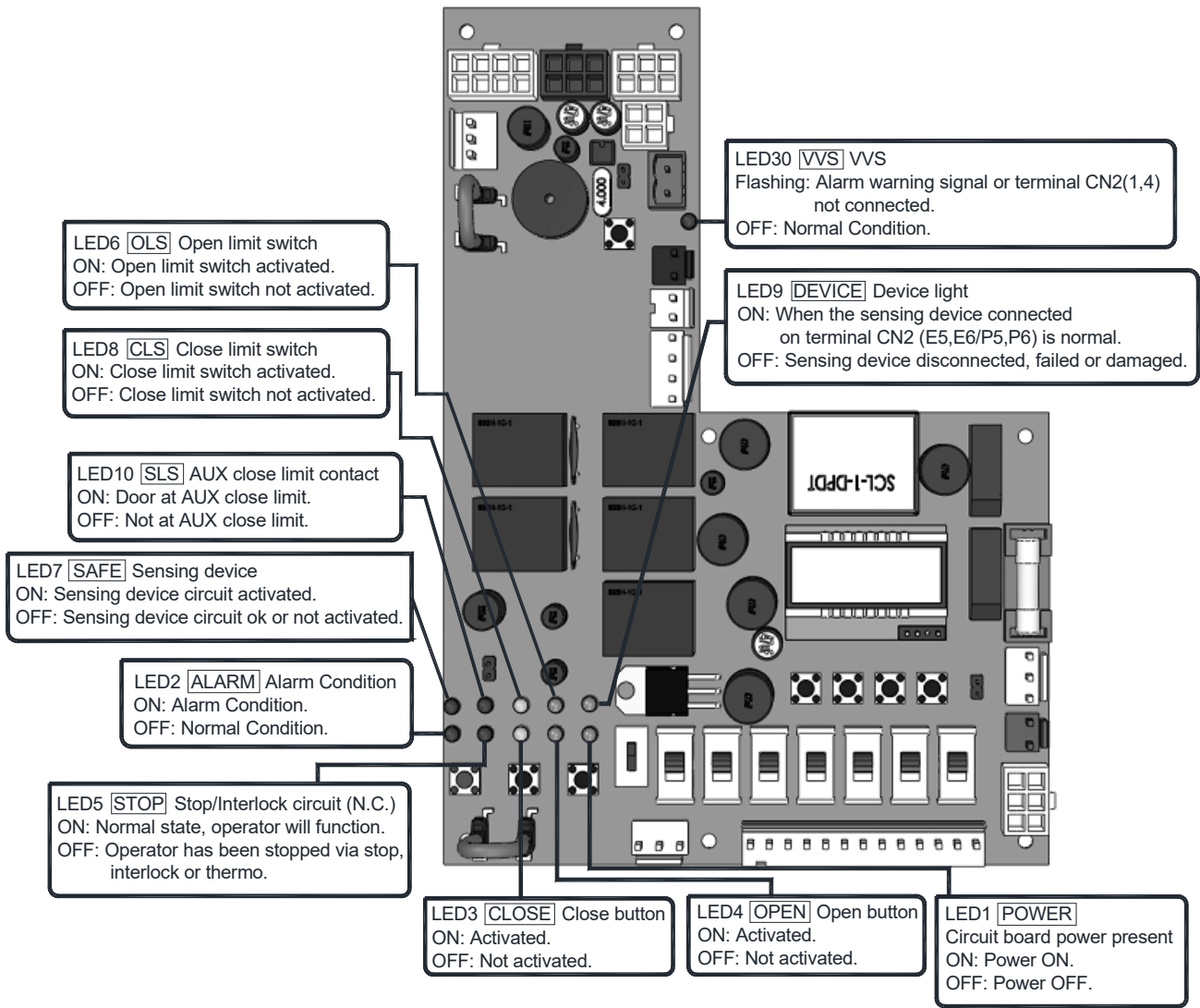

SOUND WARNINGS

Item	Description	Sound
A	Alarm warning signal	B _____ B _____ B _____ B _____
B	Terminal CN2 (1,4) not connected	B.B.B.B. B.B.B.B. B.B.B.B.

WIRING DIAGRAMS

FS-EP 115V 1 PHASE 50/60HZ LH (FSEP BOARD)
 (FOR FS-51EP, 71EP, 151EP)

EB 109EP L
 V3.08-V2

SCAN FOR
 COLOR VERSION



INPUT POWER
 115V
 1 PHASE

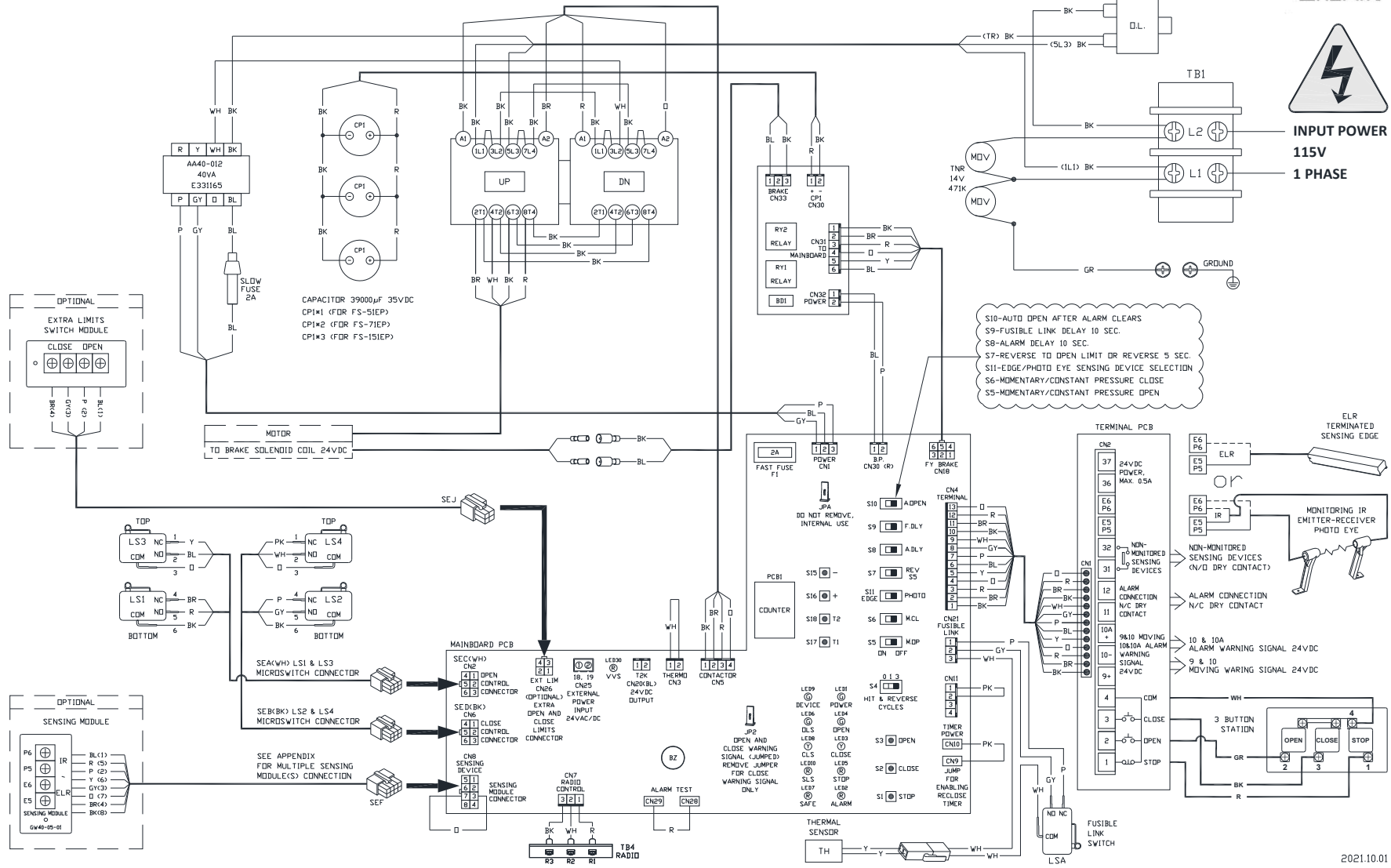

2021.10.01

FS-EP 115V 1 PHASE 50/60HZ RH (FSEP BOARD)
(FOR FS-51EP, 71EP, 151EP)

EB 109EP R
V3.08-V2

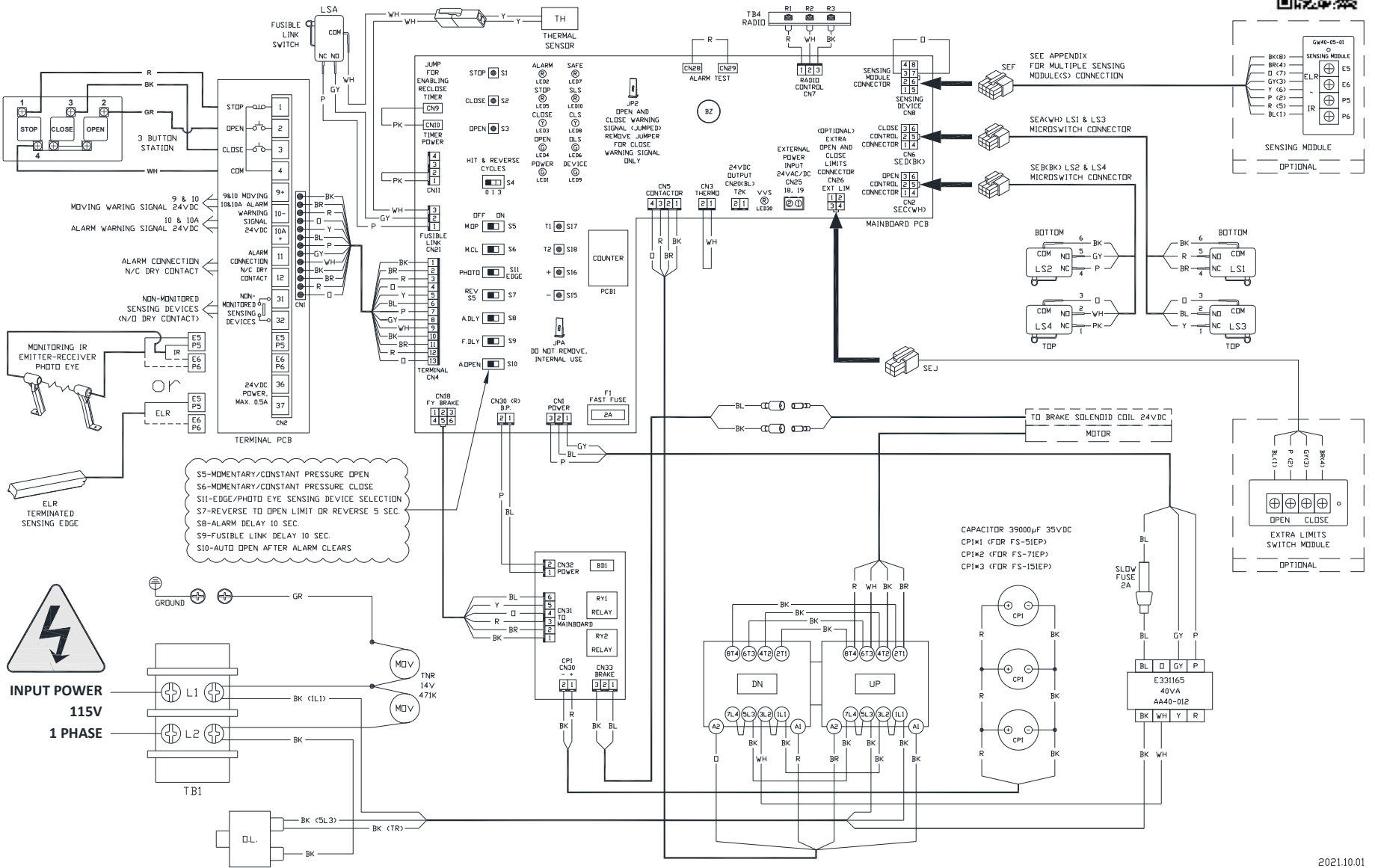

S5-MOMENTARY/CONSTANT PRESSURE OPEN
S6-MOMENTARY/CONSTANT PRESSURE CLOSE
S11-EDGE/PHOTO EYE SENSING DEVICE SELECTION
S7-REVERSE TO OPEN LIMIT OR REVERSE 5 SEC.
S8-ALARM DELAY 10 SEC.
S9-FUSIBLE LINK DELAY 10 SEC.
S10-AUTO OPEN AFTER ALARM CLEARS



INPUT POWER
115V
1 PHASE

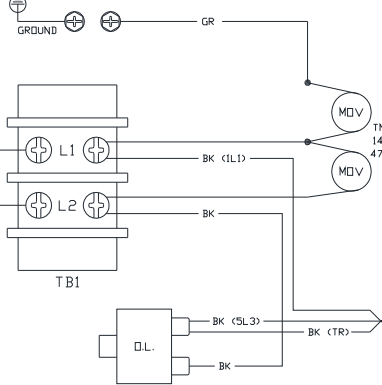

FS-EP 230V 1 PHASE 50/60HZ LH (FSEP BOARD)
 (60HZ FOR FS-32EP, 52EP, 72EP, 152EP)
 (50HZ FOR FS-55EP, 75EP, 155EP)

EB 209EP L
 V3.08-V2



INPUT POWER
230V
1 PHASE

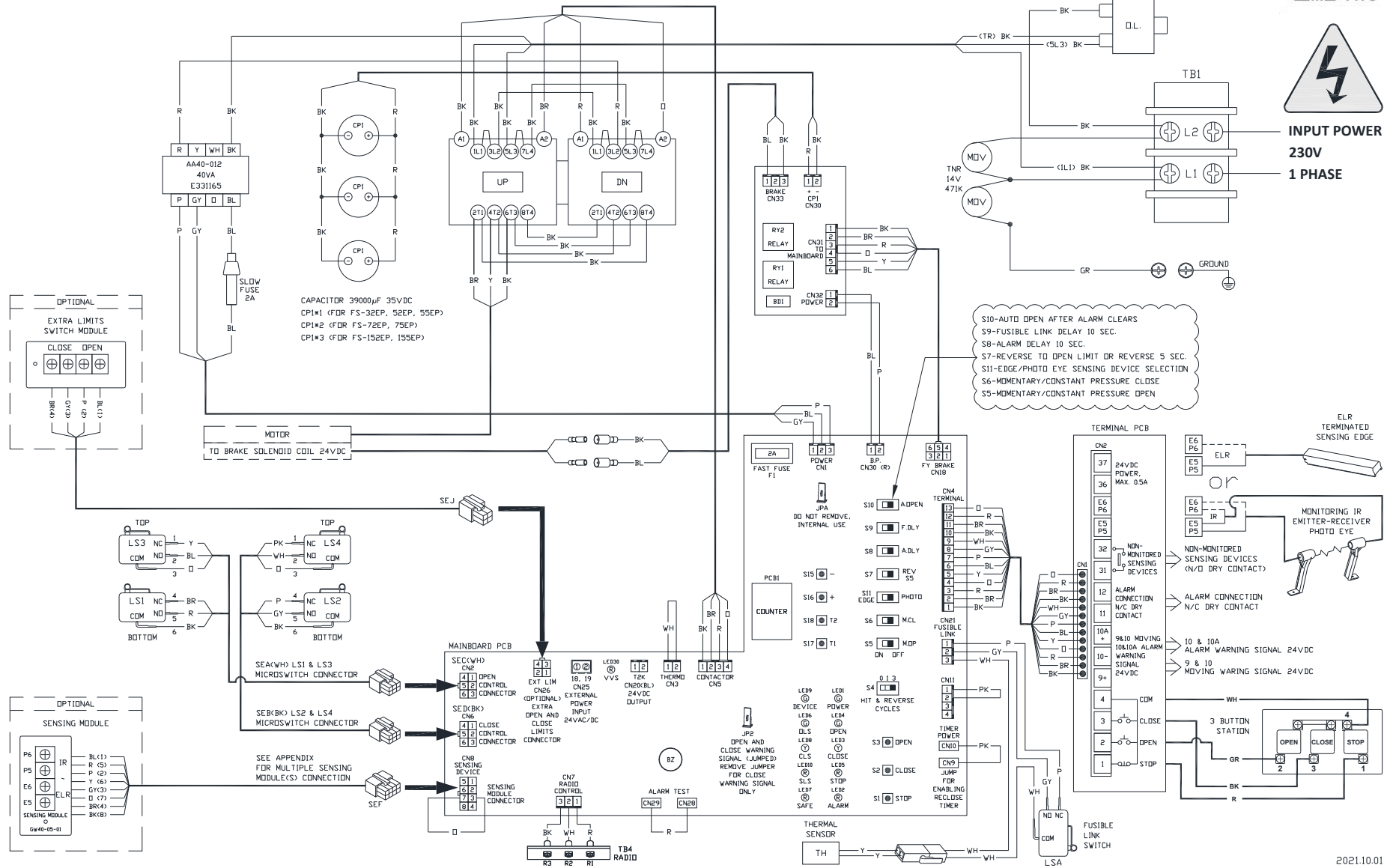

2021.10.01

FS-EP 230V 1 PHASE 50/60HZ RH (FSEP BOARD)
 (60HZ FOR FS-32EP, 52EP, 72EP, 152EP)
 (50HZ FOR FS-55EP, 75EP, 155EP)

EB 209EP R
 V3.08-V2

SCAN FOR
 COLOR VERSION

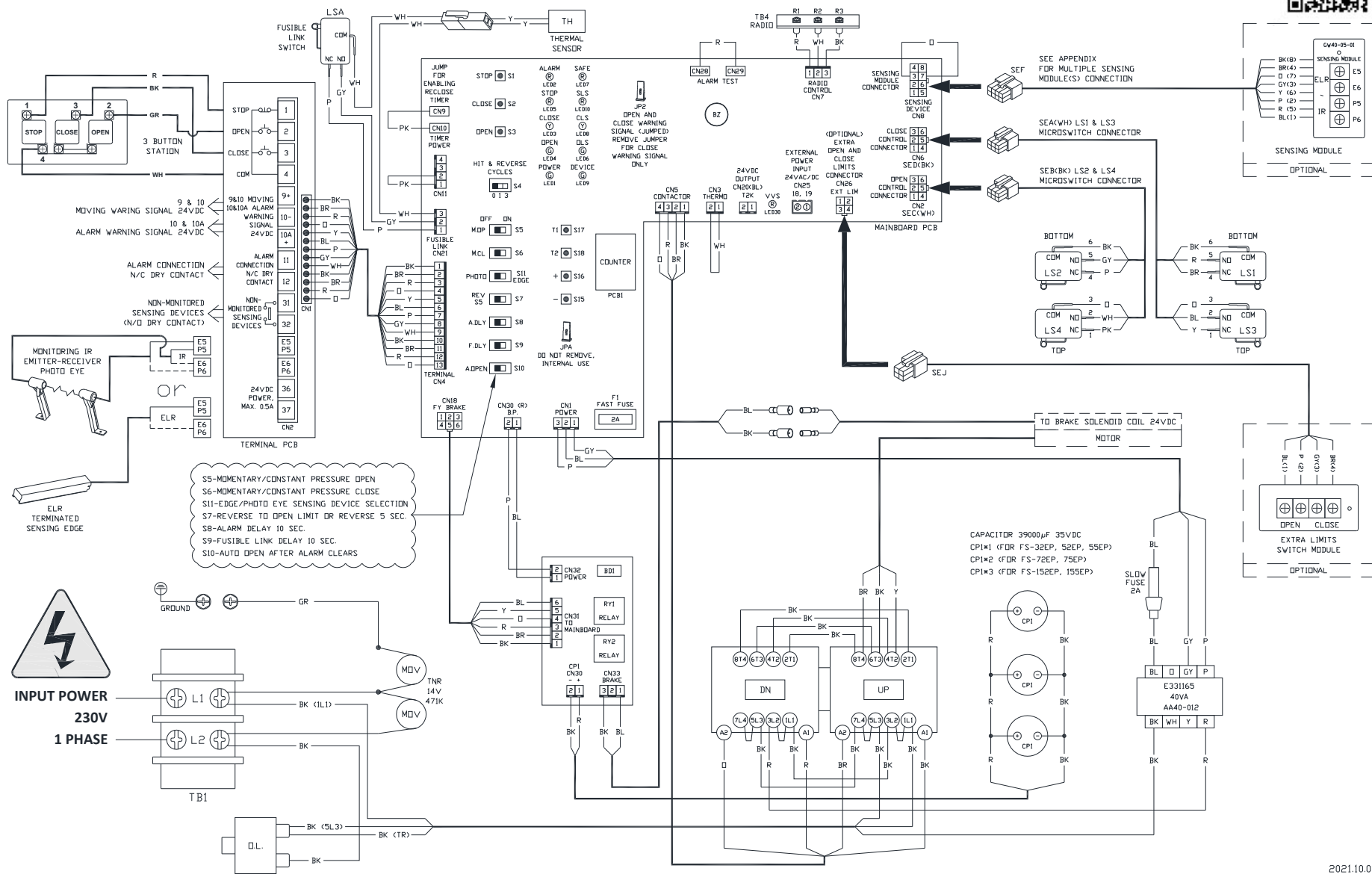

FS-EP 208V/230V 3 PHASE 50/60HZ LH (FSEP BOARD)
 (FOR FS-33EP, 53EP, 73EP, 153EP)

EB 409EP L
 V3.08-V2



INPUT POWER
 208V / 230V
 3 PHASE

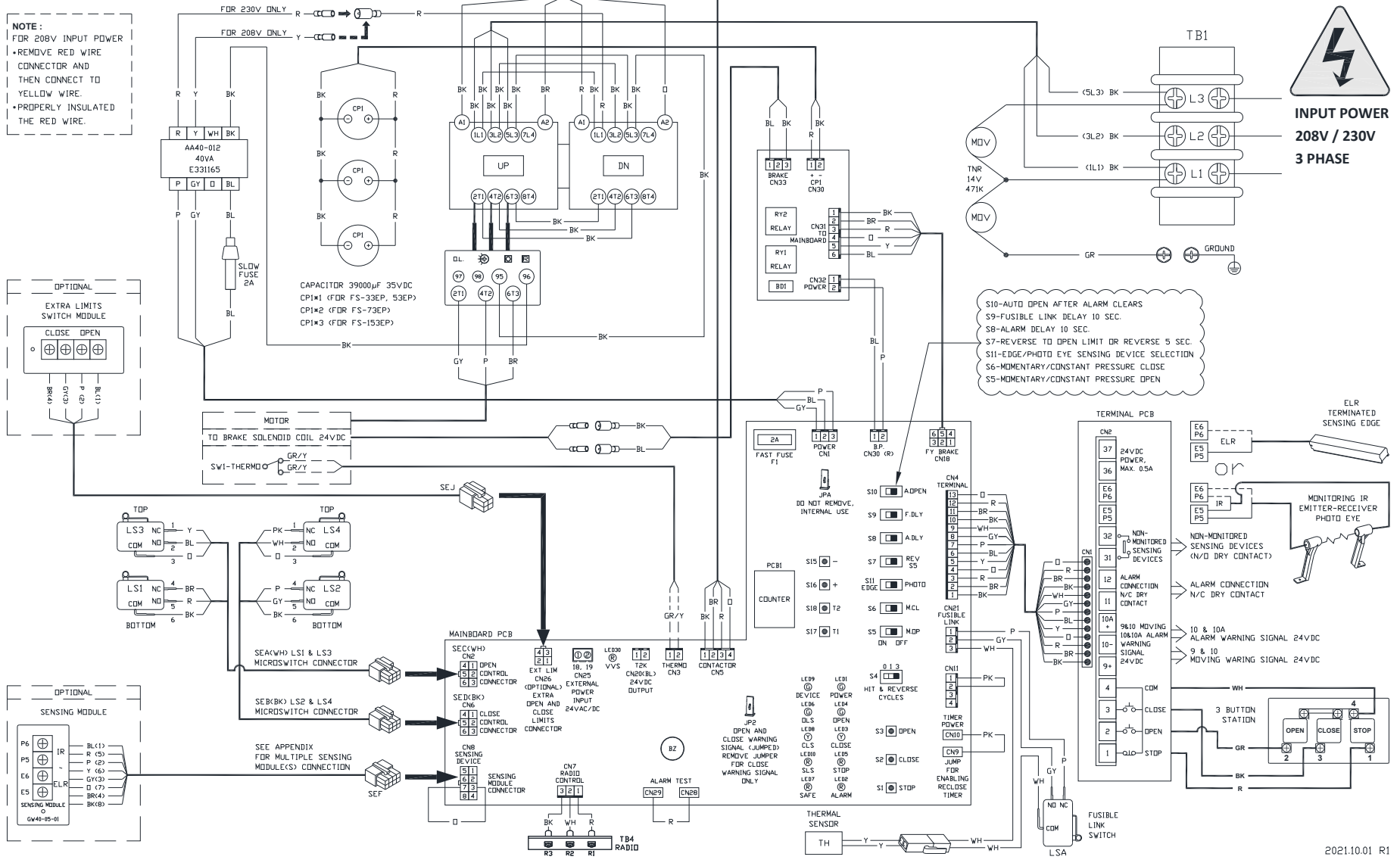

NOTE:
 FOR 208V INPUT POWER
 •REMOVE RED WIRE
 CONNECTOR AND
 THEN CONNECT TO
 YELLOW WIRE.
 •PROPERLY INSULATED
 THE RED WIRE.

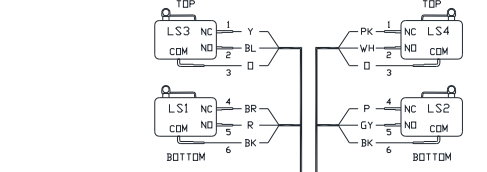
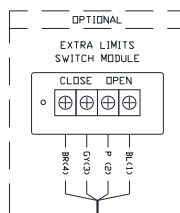

S10-AUTO OPEN AFTER ALARM CLEARS
 S9-FUSIBLE LINK DELAY 10 SEC.
 S8-ALARM DELAY 10 SEC.
 S7-REVERSE TO OPEN LIMIT OR REVERSE 5 SEC.
 S11-EDGE/PHOTO EYE SENSING DEVICE SELECTION
 S6-MOMENTARY/CONSTANT PRESSURE CLOSE
 S5-MOMENTARY/CONSTANT PRESSURE OPEN

2021.10.01 R1

FS-EP 208V/230V 3 PHASE 50/60HZ RH (FSEP BOARD)
 (FOR FS-33EP, 53EP, 73EP, 153EP)

EB 409EP R
 V3.08-V2

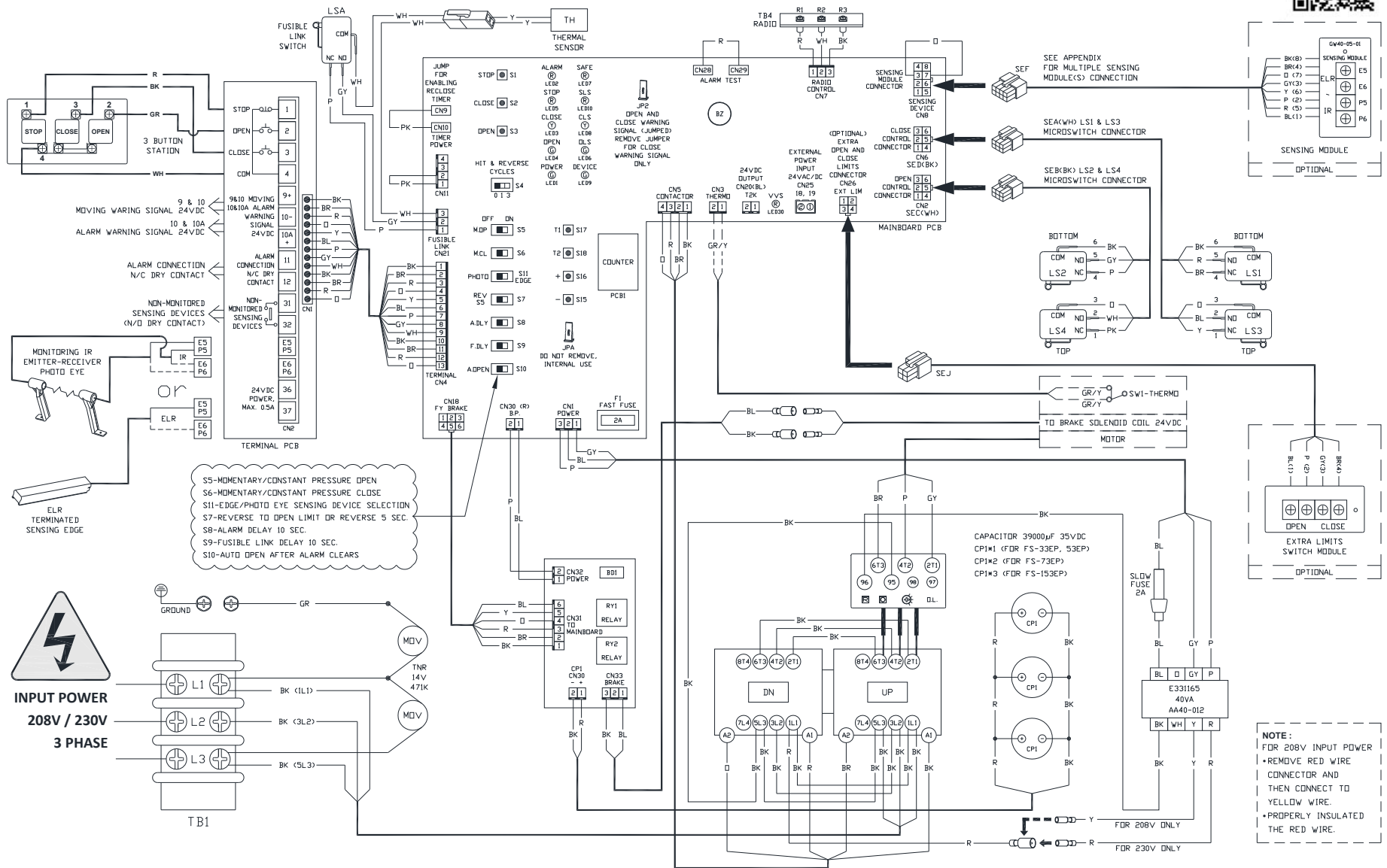

S5-MOMENTARY/CONSTANT PRESSURE OPEN
 S6-MOMENTARY/CONSTANT PRESSURE CLOSE
 S11-EDGE/PHOTO EYE SENSING DEVICE SELECTION
 S7-REVERSE TO OPEN LIMIT OR REVERSE 5 SEC.
 S8-ALARM DELAY 10 SEC.
 S9-FUSIBLE LINK DELAY 10 SEC.
 S10-AUTO OPEN AFTER ALARM CLEARS



INPUT POWER
 208V / 230V
 3 PHASE

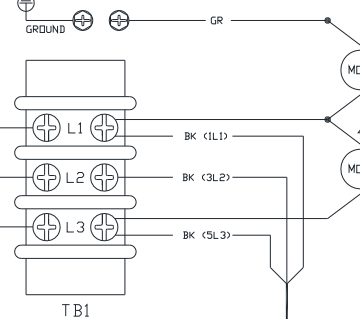

NOTE:
 • FOR 208V INPUT POWER
 • REMOVE RED WIRE
 CONNECTOR AND
 THEN CONNECT TO
 YELLOW WIRE.
 • PROPERLY INSULATE
 THE RED WIRE.

FS-EP 460V 3 PHASE 50/60HZ LH (FSEP BOARD)
 (FOR FS-34EP, 54EP, 74EP, 154EP)

EB 509EP L
 V3.08-V2



INPUT POWER
460V
3 PHASE

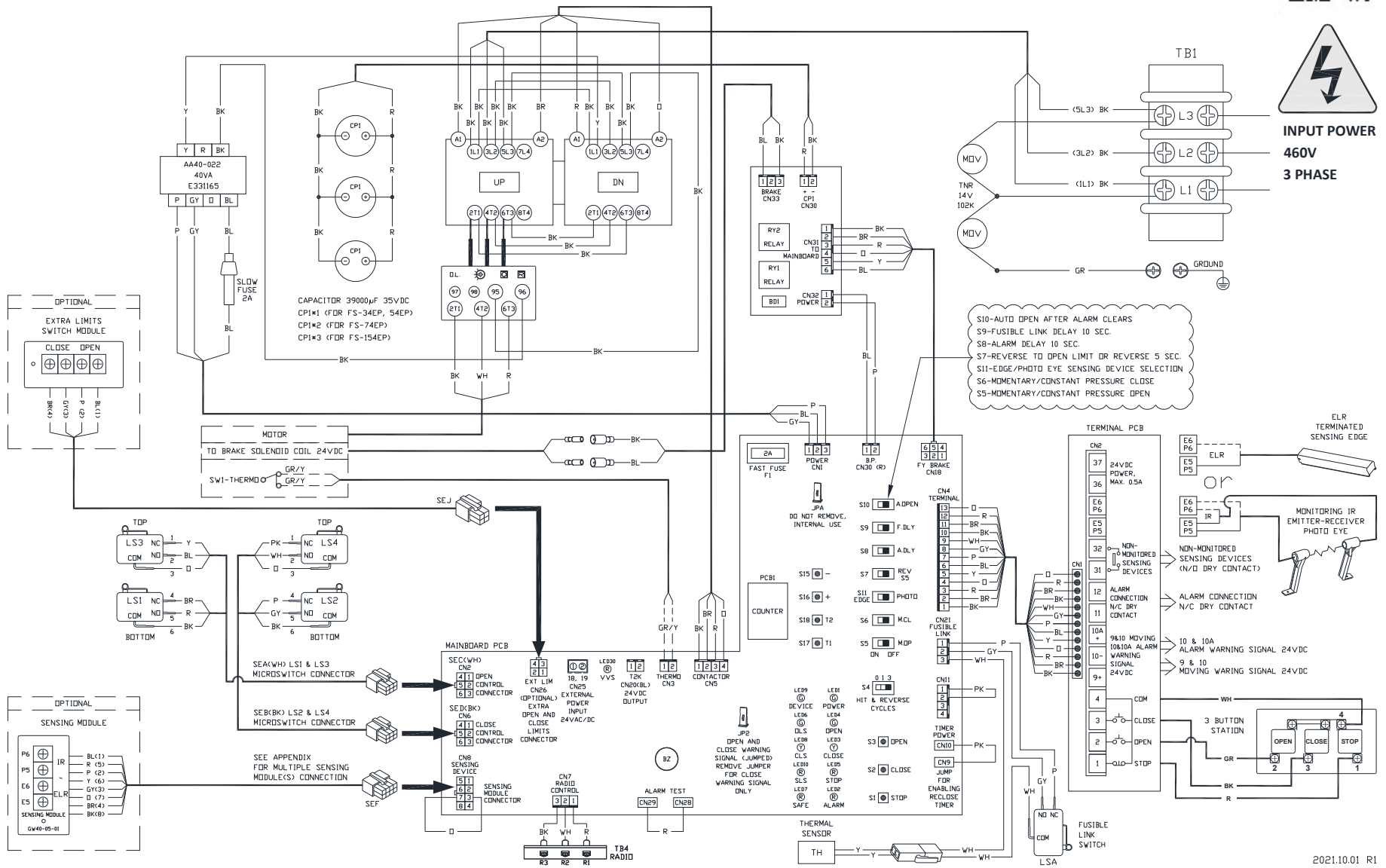

S10-AUTO OPEN AFTER ALARM CLEARS
 S9-FUSIBLE LINK DELAY 10 SEC.
 S8-ALARM DELAY 10 SEC.
 S7-REVERSE TO OPEN LIMIT OR REVERSE 5 SEC.
 S11-EDGE/PHOTO EYE SENSING DEVICE SELECTION
 S6-MOMENTARY/CONSTANT PRESSURE CLOSE
 S5-MOMENTARY/CONSTANT PRESSURE OPEN

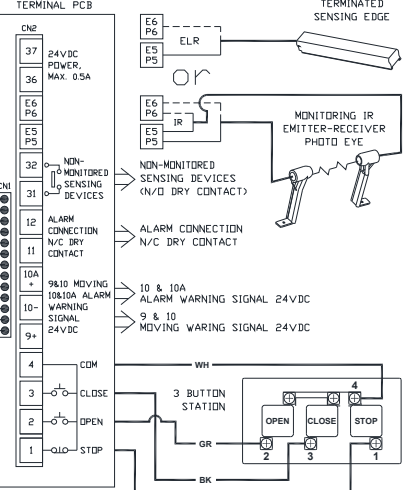

2021.10.01 R1

FS-EP 460V 3 PHASE 50/60HZ RH (FSEP BOARD)
 (FOR FS-34EP, 54EP, 74EP, 154EP)

EB 509EP R
 V3.08-V2

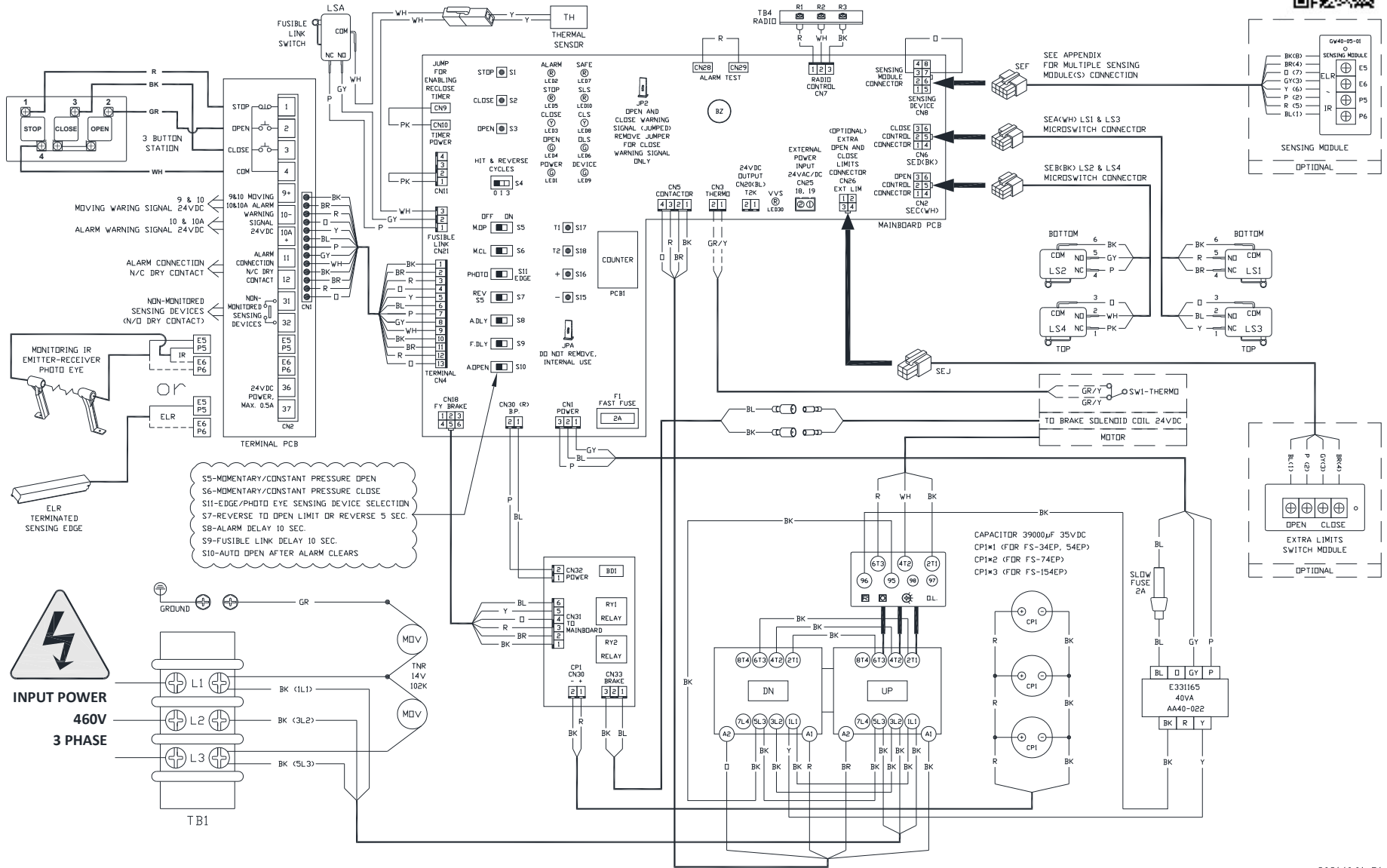

S5-MOMENTARY/CONSTANT PRESSURE OPEN
 S6-MOMENTARY/CONSTANT PRESSURE CLOSE
 S11-EDGE/PHOTO EYE SENSING DEVICE SELECTION
 S7-REVERSE TO OPEN LIMIT OR REVERSE 5 SEC.
 S8-ALARM DELAY 10 SEC.
 S9-FUSIBLE LINK DELAY 10 SEC.
 S10-AUTO OPEN AFTER ALARM CLEARS



INPUT POWER
 460V
 3 PHASE

FS-EP 575V 3 PHASE 60HZ LH (FSEP BOARD)
 (FOR FS-38EP, 58EP, 78EP, 158EP)

EB 709EP L
 V3.08-V2



INPUT POWER
575V
3 PHASE

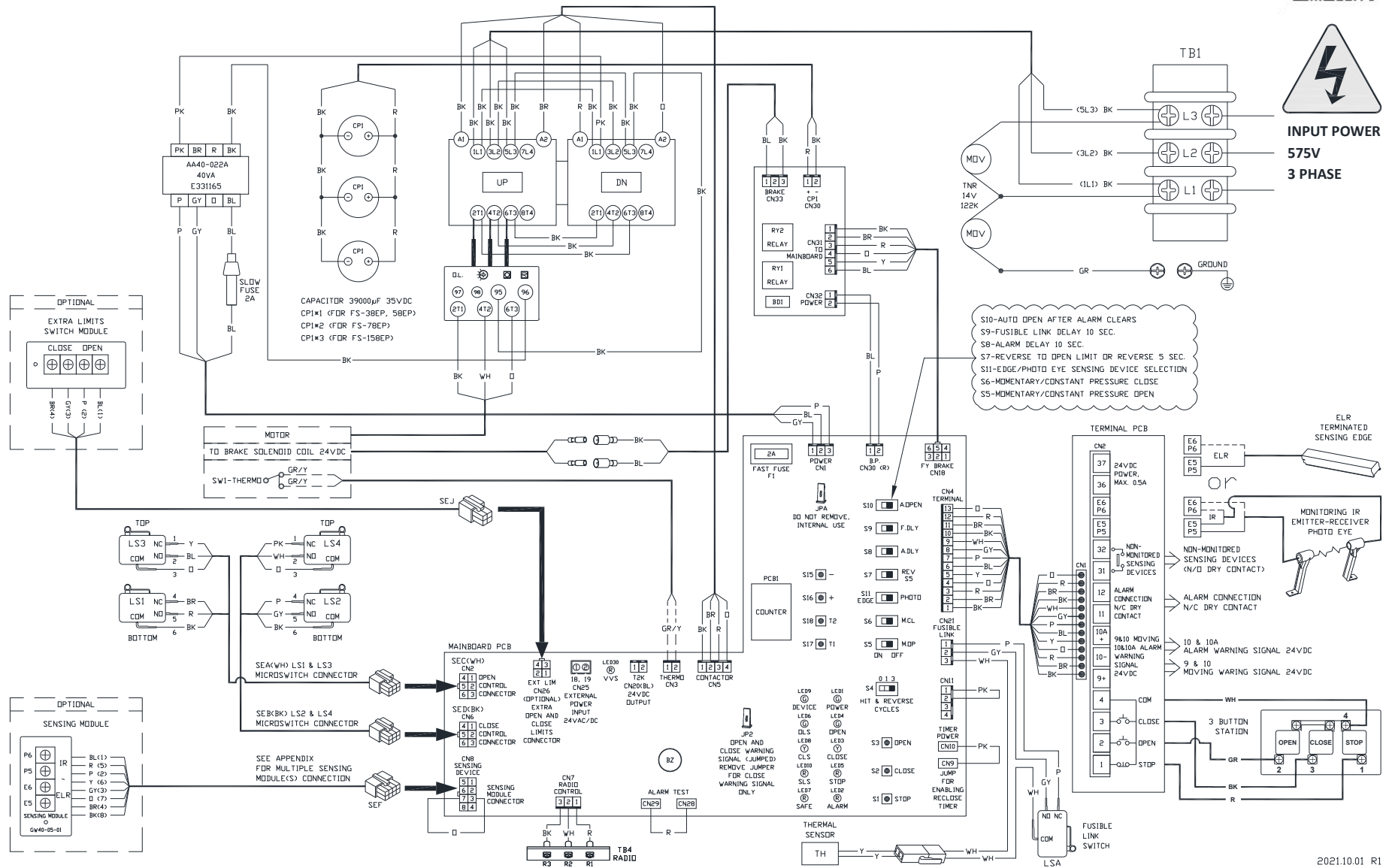

FS-EP 575V 3 PHASE 60HZ RH (FSEP BOARD)
 (FOR FS-38EP, 58EP, 78EP, 158EP)

EB 709EP R
 V3.08-V2

SCAN FOR
 COLOR VERSION

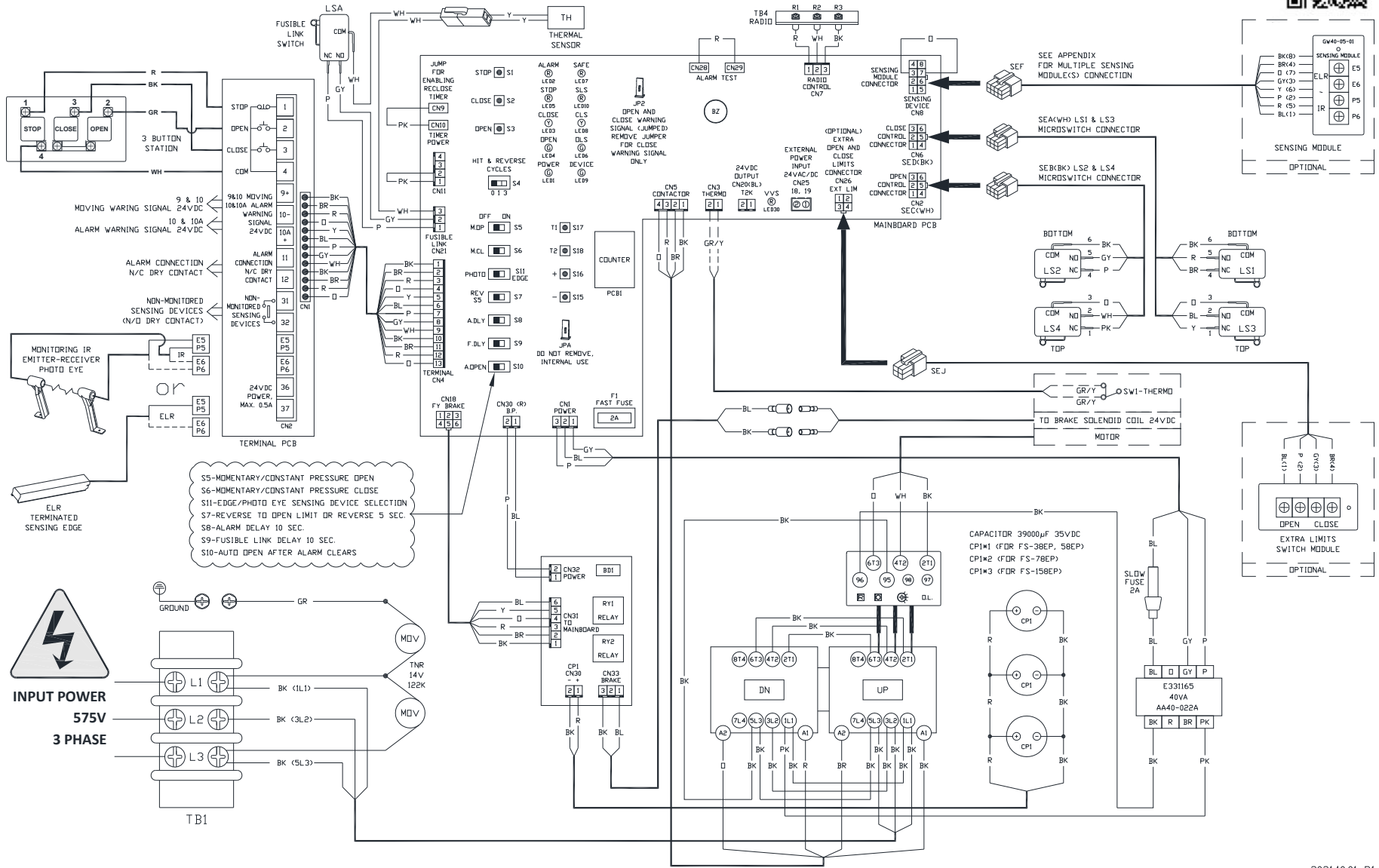

2021.10.01 R1

IMPORTANT SAFETY INSTRUCTIONS

WARNING –To reduce the risk of severe injury or death:

1. READ AND FOLLOW ALL INSTRUCTIONS.
2. Never let children operate or play with door controls. Keep the remote control (where provided) away from children.
3. Personnel should keep away from a door in motion and keep the moving door in sight until it is completely closed or opened. NO ONE SHOULD CROSS THE PATH OF A MOVING DOOR.
4. Test the door's safety features at least once a month. After adjusting either the force or the limit of travel, retest the door operator's safety features. Failure to adjust the operator properly may cause severe injury or death.
5. For products having a manual release, if possible, use the manual release only when the door is closed. Use caution when using this release when the door is open. Weak or broken springs may cause the door to fall rapidly, causing severe injury or death.
6. KEEP DOORS PROPERLY OPERATING AND BALANCED. See Door Manufacturer's Owner's Manual. An improperly operating or balanced door could cause severe injury or death. Have trained door systems technician make repairs to cables, spring assemblies, and other hardware.
7. **SAVE THESE INSTRUCTIONS.**

FUSIBLE LINK CONNECTIONS

- ❖ REMOVE COTTER PIN FROM RELEASE ASSEMBLY AFTER INSTALLATION IS COMPLETE.

Refer to the fire door installation instructions for connection of the release assembly or consult NFPA-80 and the authority having jurisdiction for fusible link location(s) and method.

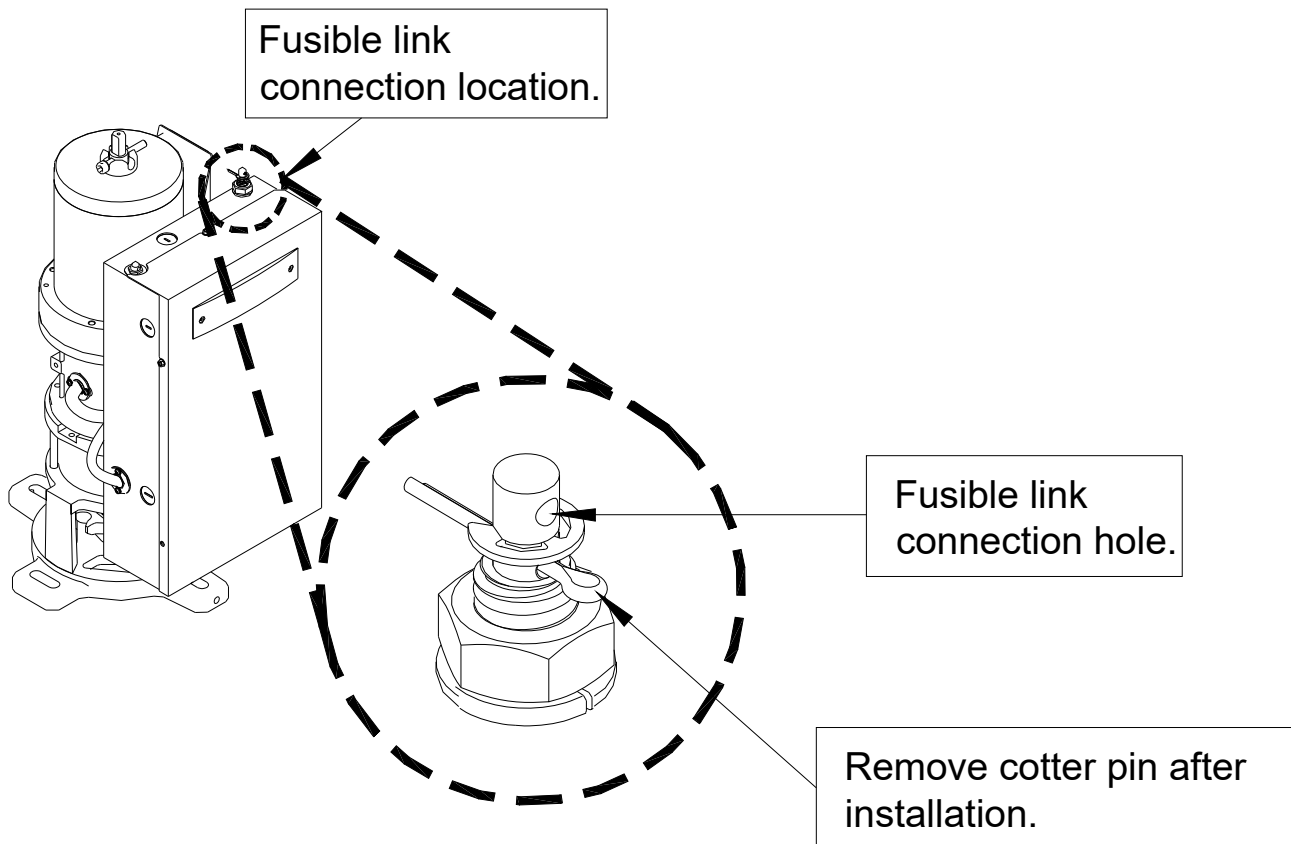

* Illustration only, not drawn to scale. See product for actual details.

TESTING

PUSH BUTTON STATION TESTING

1. If a 3-button control station is used to operate the door, push the “OPEN” button to open the door, push the “CLOSE” button to close the door, push the “STOP” button to stop movement of the door while opening or closing. Removing pressure from the “CLOSE” button will cause the door to stop.
2. If a key switch control station is used to operate the door, turn the key to the “OPEN” position to open the door, turn the key to the “CLOSE” position to close the door, push the “STOP” button to stop movement of the door while opening or closing. Removing pressure from the “CLOSE” key position will cause the door to stop.
3. Door may also be operated by remote devices.

WARNING

If a sensing edge is not installed on the bottom of the door, and removing pressure from the “CLOSE” button or key switch position does not cause the door to stop, this condition must be corrected immediately. Improper operation could result in serious injury or death to person(s) trapped beneath the door.

MAINTENANCE INSTRUCTIONS

The brake is a self-adjusting brake. It is maintenance free. The brake assembly requires no additional adjustments for its lifetime.

If an entrapment protection device is used, i.e. sensing edge or photoelectric sensors, please consult the manufacturer for maintenance instruction.

WARNING

Disconnect power supply to the operator before servicing.

Check the following items at the intervals listed:

CHECK LIST	DESCRIPTION	EVERY 3 MONTHS	EVERY 6 MONTHS	EVERY 12 MONTHS
Drive Chain	Check for excessive slack. Check & adjust as required Lubricate.	●		
Sprockets	Check set screw tightness	●		
Fasteners	Check & tighten as required		●	
Bearings & Shafts	Check for wear & lubricate	●		
Drop-test	Inspect door, drop-test for proper operation and full closure per NFPA-80			●

- ❖ Do not lubricate motor. Motor bearings are rated for continuous operation.
- ❖ Inspect and service whenever a malfunction either door or operator is observed or suspected.
- ❖ Before servicing, always disconnect power supply to the operator.
- ❖ Replace fuses only with those of the same type and rating.
- ❖ All replacement parts must be obtained from the door manufacturer per NFPA-80.

WARNING

Do not place hands or tools in or near the operator when the power is connected or when testing control or sensing devices. Always disconnect power before servicing or adjusting the operator.

U.S. GEAR

Covered under US Pat. # 7,275,631, # 7,161,100 and additional patents pending.

APPENDIX 1: Multiple Sensing Devices Connection Instruction

Multiple Sensing Devices Connection Instruction

Warning: Power OFF When Connecting.

QST-FS-EP-ADAPTER-7

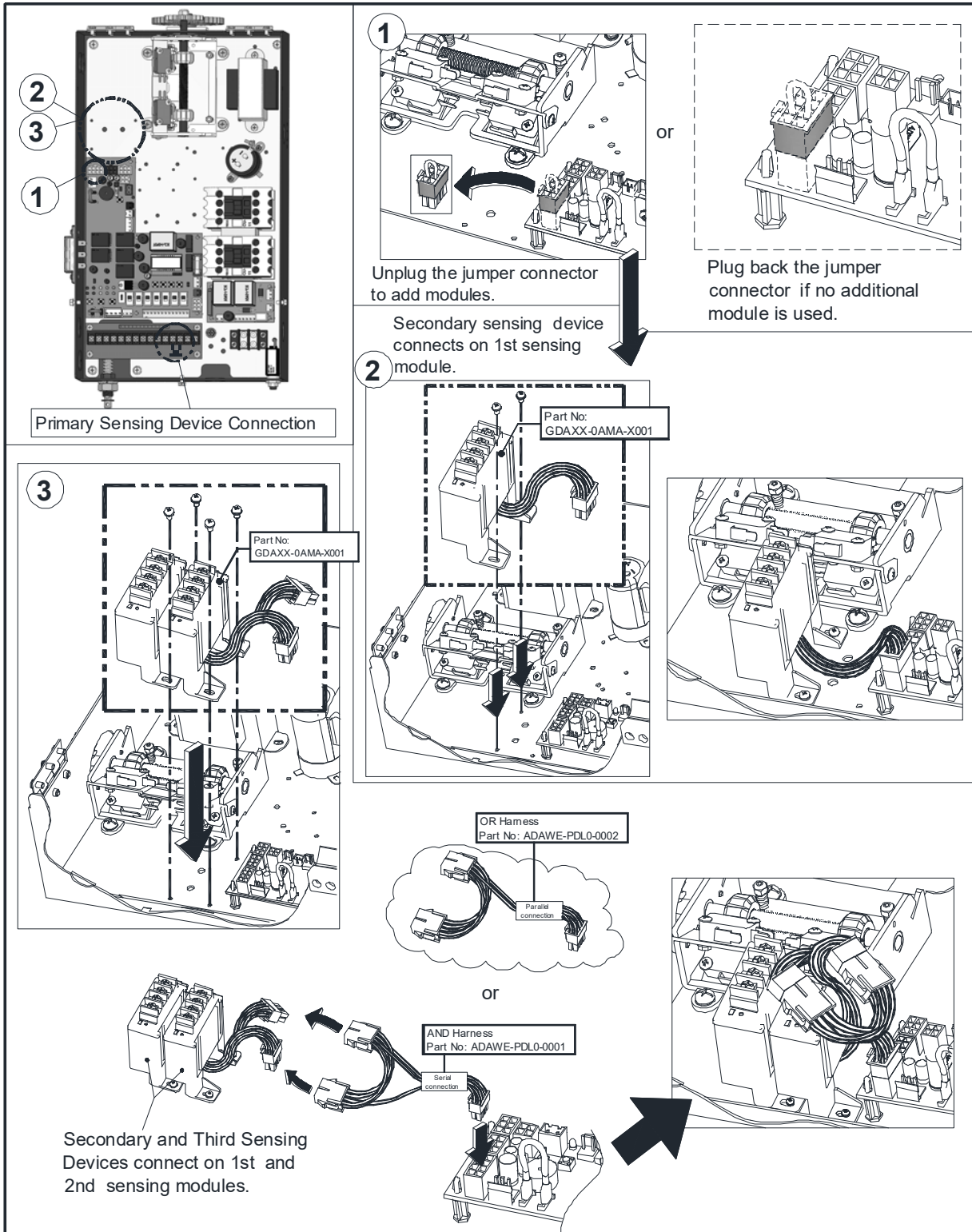

APPENDIX 2: Control Connections Diagrams

Control Connections Diagrams

CCD-PCB-A01

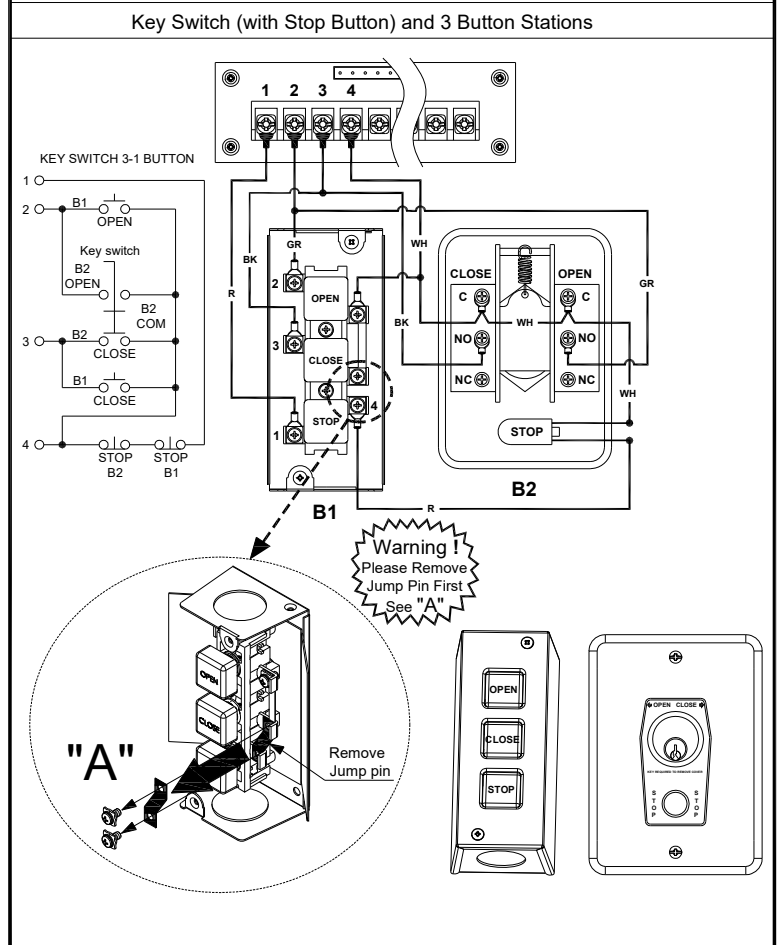
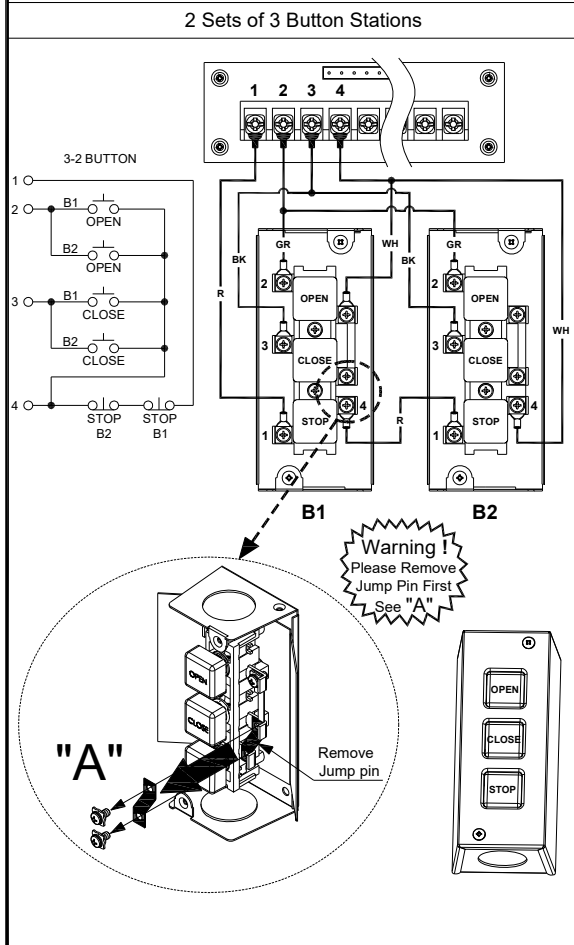
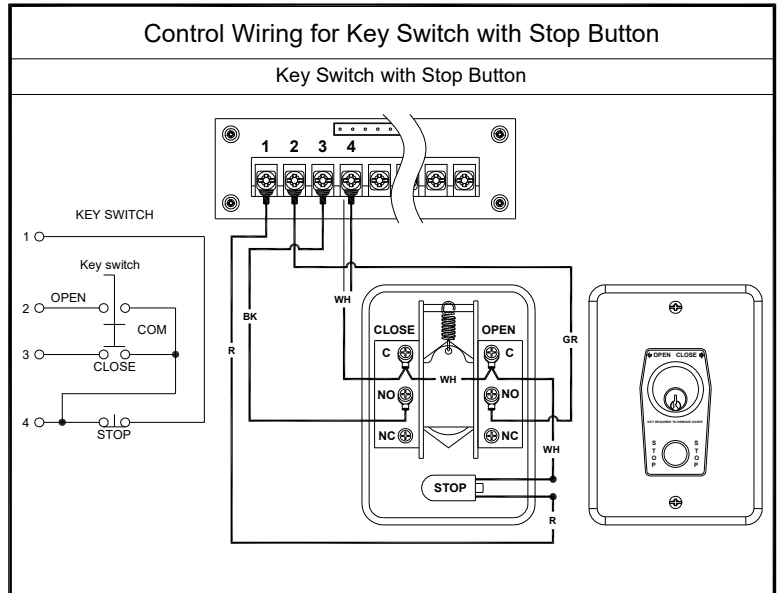
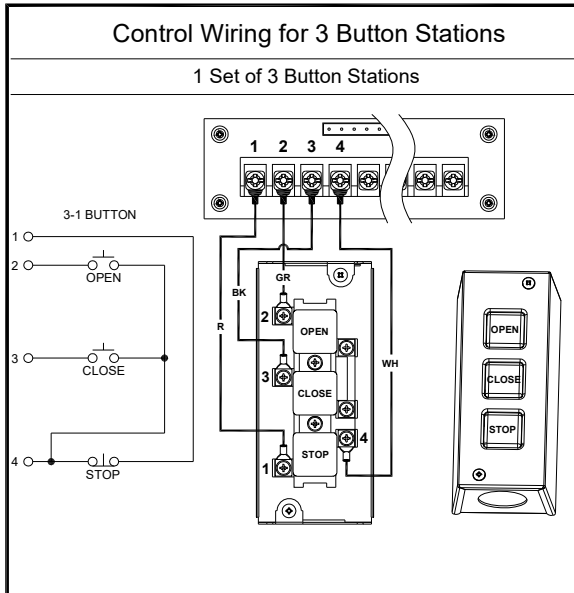

APPENDIX 3: Control Connections Diagrams

Control Connections Diagrams

CCD-PCB-B02

Wiring 3 Button Stations With Key Lockout

1 Set

KEY LOCKOUT 3 BUTTON

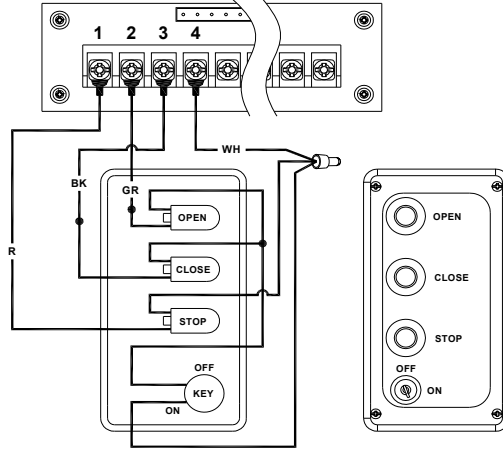
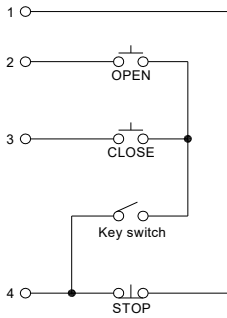

With and without key lockout

KEY LOCKOUT 3-2 BUTTON

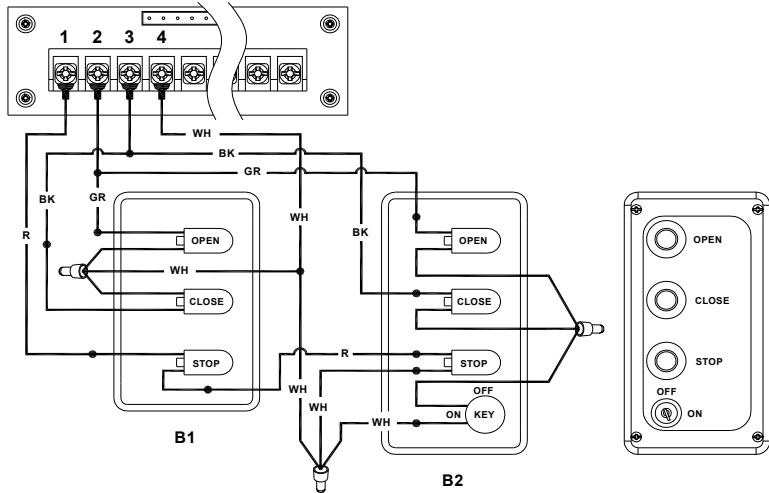
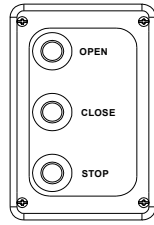
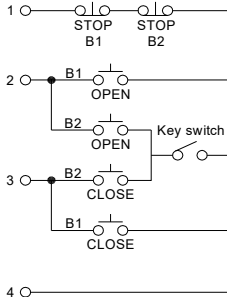

Ceiling Pull Switch Station

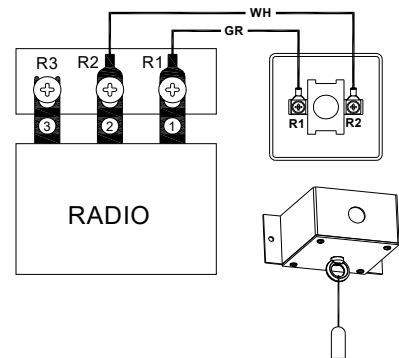
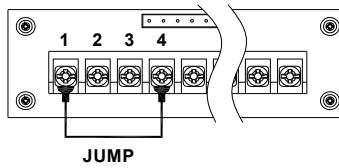
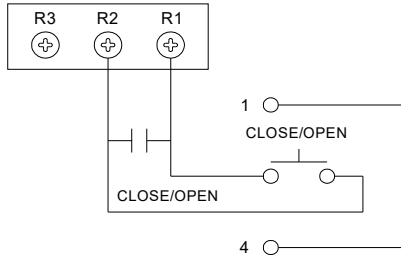

APPENDIX 4: External Timer Defeat Switch Connection

EXTERNAL TIMER DEFEAT SWITCH CONNECTION-FSEP BOARD

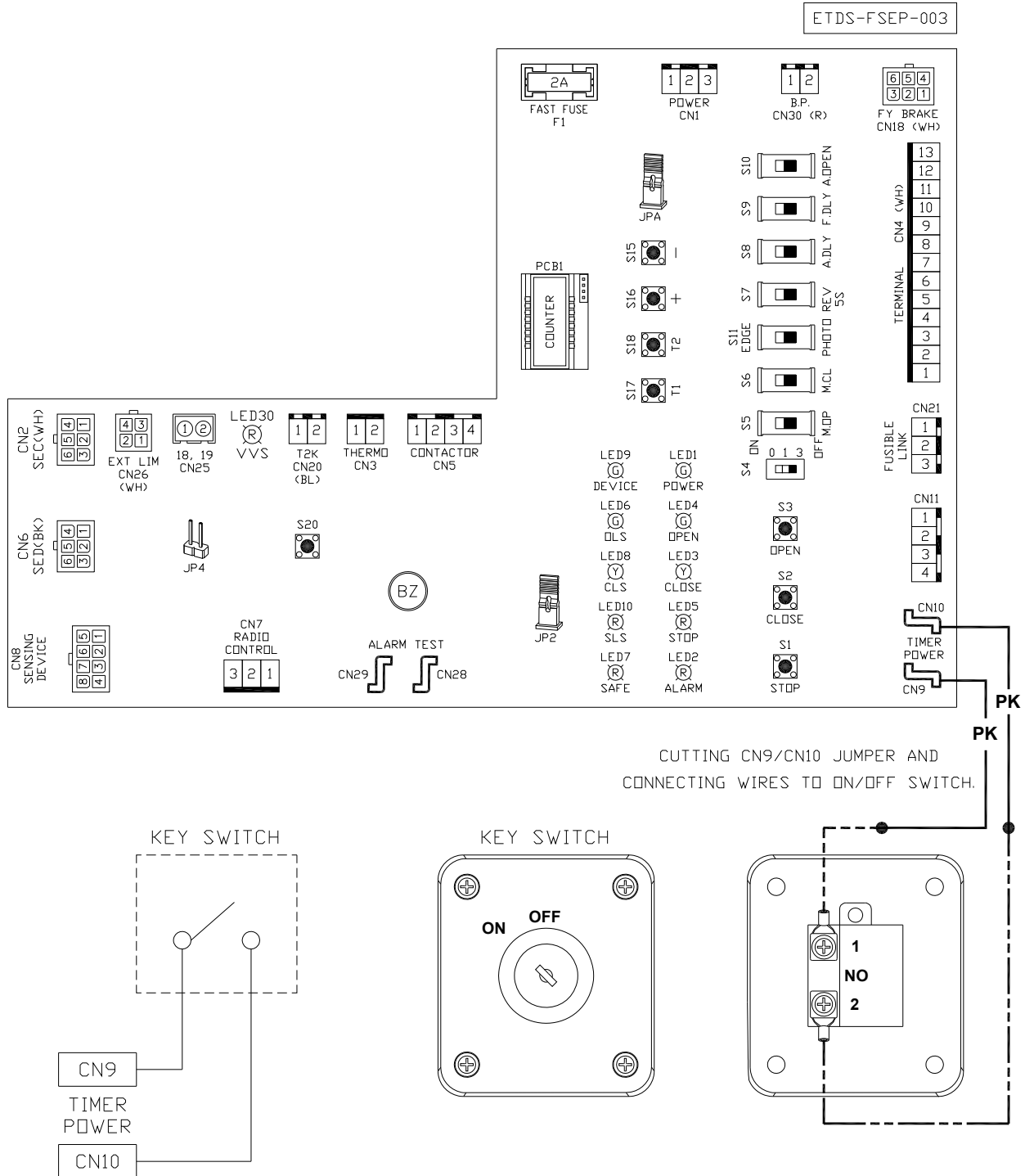

APPENDIX 5: Wiring Change Instruction from 230V to 208V 3 Phase Operator

Wiring Change Instruction from 230V to 208V 3 Phase Operator

FS EP Series

FS-EP-3P-V02

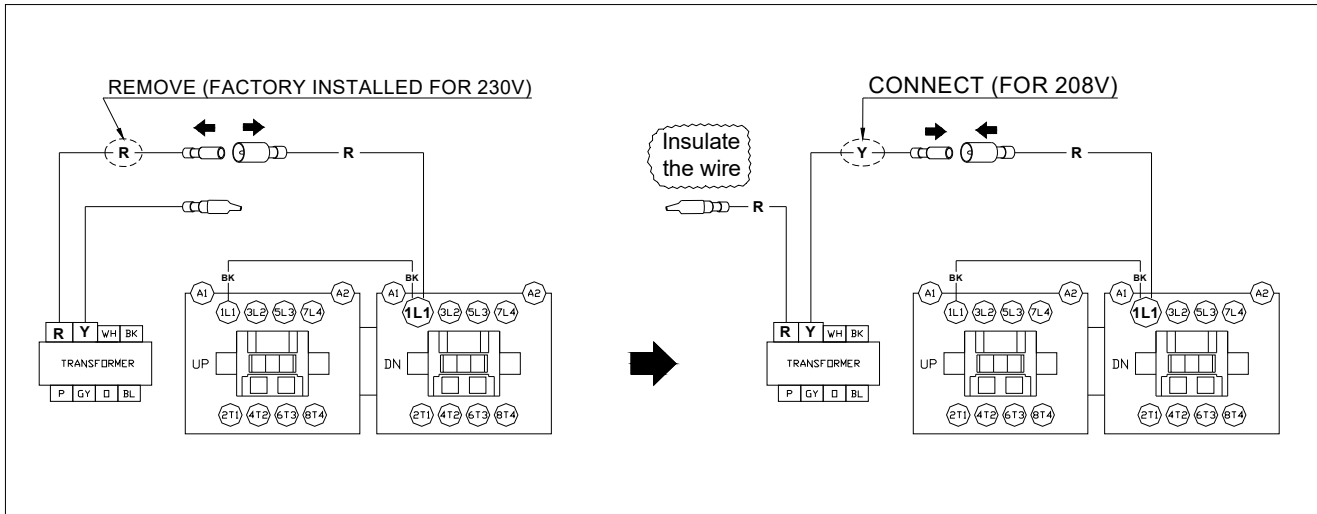

1. Unplug the red "230V" wire connector from the red "PWR" wire connector. Remove the insulating cap from the yellow "208V" wire connector.

2. Put the insulating cap on the red "230V" wire connector. Plug the yellow "208V" wire connector into the red "PWR" wire connector.

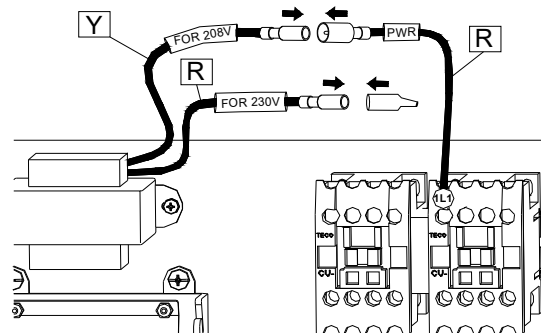
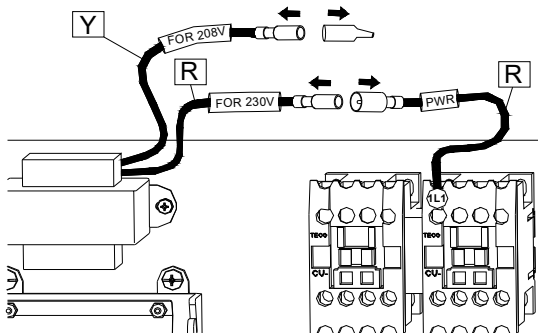

3. Completed.

