

INSTALLATION INSTRUCTIONS

AND

OPERATION MANUAL

**TUBULAR MOTOR 550 DMI
TUBULAR MOTOR 6100 DMI**

IMPORTANT INSTALLATION INSTRUCTIONS

WARNING: To reduce the risk of severe injury or death read and follow all installation instructions

1. Do not connect the door operator to the power source until instructed to do so.
2. Locate the switch/control station:
 - within sight of the door
 - at a minimum height of 5 feet from the floor so small children cannot reach it
 - away from all moving parts of the door.
3. Make sure the available power supply to be connected to the operator is of the same voltage, frequency, phase, and wattage as indicated for the operator.
4. Read and understand the wiring diagrams of the operator and the switch/control station, and any other equipment to be connected to the operator.
5. To avoid damage to the door and operator, make all door locks inoperative. Secure locks in the unlocked position, or install external electrical interlocks to prevent operation with the locks engaged. (NOTE: external electrical interlocks should be provided only with a Smart Motor Control (SMC).
6. Always disconnect power when installing or servicing the door operator or the door itself.
7. All wiring is to comply with National Electric Code (NEAC) and local code requirements.
8. Consult factory for any changes as they may affect the operation of the door and result in damage or injuries.

SPECIFICATIONS

TUBULAR MOTOR TYPE 550 DMI

Voltage.....	115 / 1 phase / 60 Hz
Watts.....	210
Amps.....	2.1
Protection index.....	IP44
Torque.....	440 in.lb.
Speed.....	12 rpm
Limit adjustment.....	Progressive
Limit switch (max. turns).....	28
Run time.....	5 min.
Override.....	manual
DMI reduction ratio.....	27:1
Cable length.....	8 ft

TUBULAR MOTOR TYPE 6100 DMI

Voltage.....	115 / 1 phase / 60 Hz
Watts.....	430
Amps.....	3.8
Protection index.....	IP44
Torque.....	880 in.lb.
Speed.....	14 rpm
Limit adjustment.....	Progressive
Limit switch (max. turns).....	28
Run time.....	5 min.
Override.....	manual
DMI reduction ratio.....	55:1
Cable length.....	8 ft

INSTALLATION INSTRUCTIONS

Tubular motor mounts inside the door's barrel. Based on the pipe diameter, a sleeve adapter or ring adapters mounted inside the pipe are used to compensate for the difference between the outside diameter of the motor and the inside diameter of the pipe. When inserting the tubular motor into the barrel ensure that the plastic tab on the motor aligns with the keyway in the adapter. The crown at the opposite end of the motor will fit inside a drive wheel or differential (depending on the door type). When inserting the motor into the barrel make sure that the motor is parallel with the pipe and that the motor slides completely into the barrel. Gently rotate the tubular motor while pushing it in to allow for the crown to engage with the drive wheel/differential.

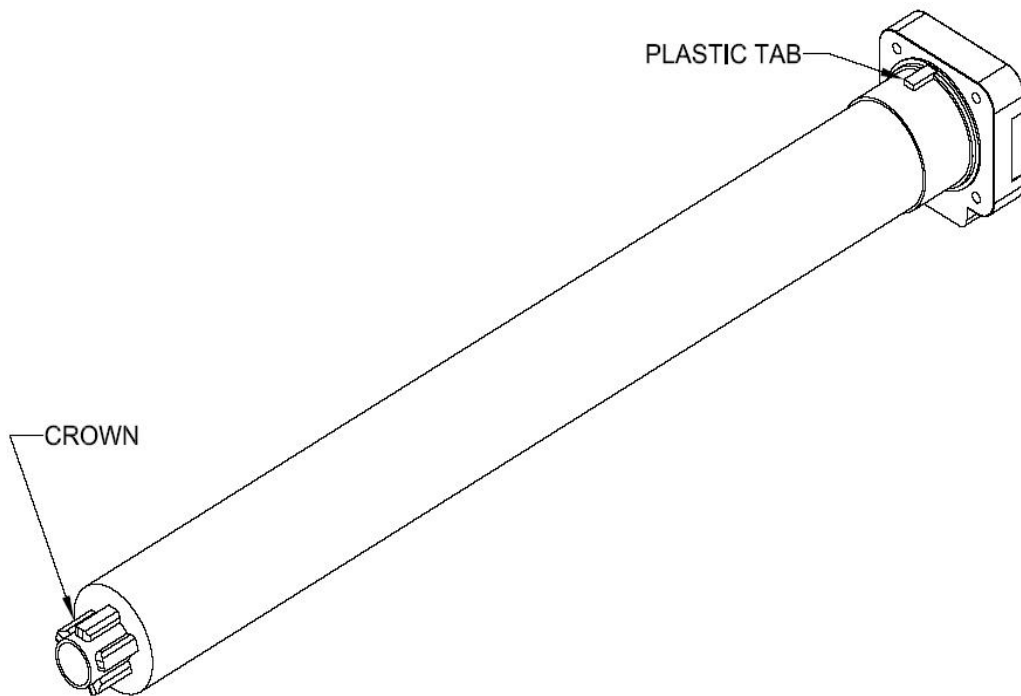

Tubular Motor

Tubular motors are supported by two motor mounting angles bolted to the drive bracket plate. See the drawings below for motor mounting configurations.

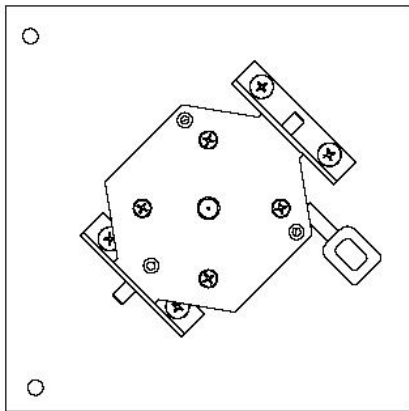
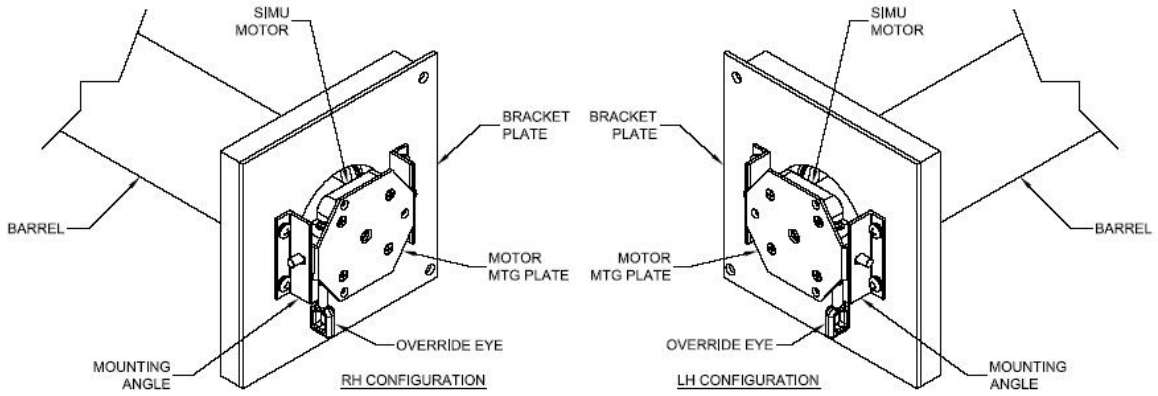

LH CONFIGURATION
FRAME UNIT

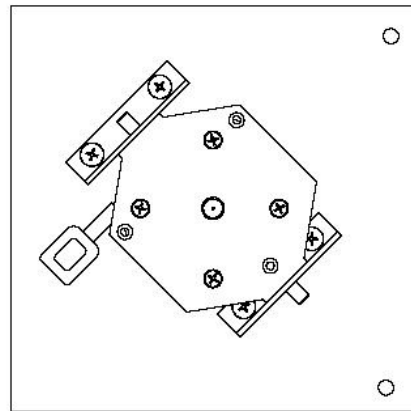

RH CONFIGURATION
FRAME UNIT

LIMIT SWITCH ADJUSTMENT

A limit switch adjustment tool is provided with the motor.

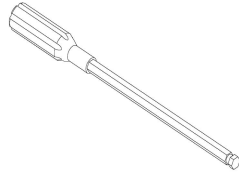

Limit switch adjustment tool

LIMIT ADJUSTMENT SCREWS ON OPPOSITE SIDE FROM MOTOR CABLE

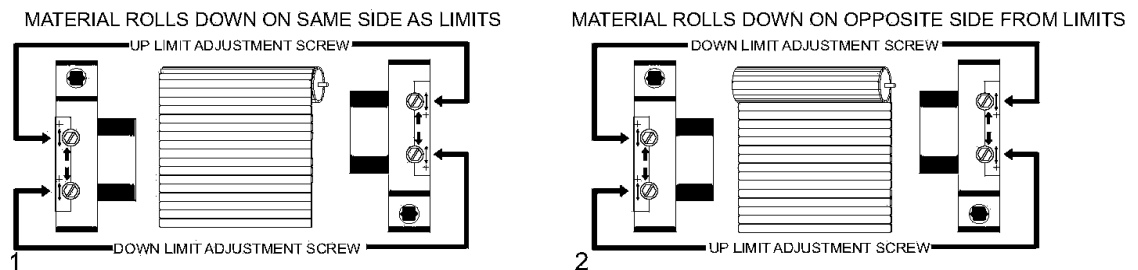

LIMIT ADJUSTMENT SCREWS ON SAME SIDE AS MOTOR CABLE

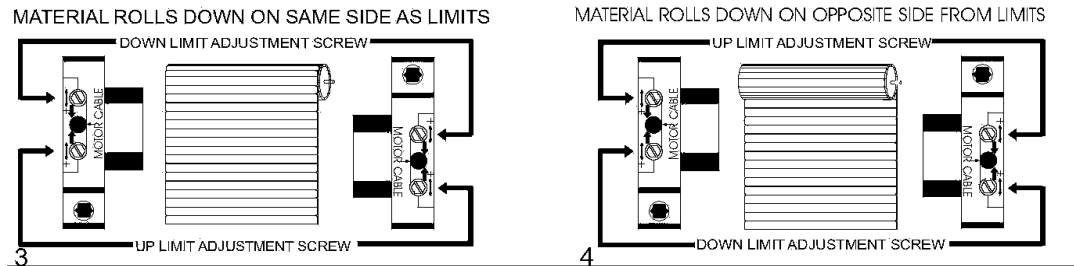

1) Identify which limit adjustment screw controls the up limit and which controls the down limit (see above diagrams). It is important to note that the arrows by the limit adjustment screw refer to the tube's rotation. Thus if the material comes off the tube on the back side and you are adjusting the limits from the side that the motor cable is not on (as per diagram 2), the limit adjustment screw with the arrow facing up controls the down limit and vice versa.

2) Turning an adjustment screw positive (+) will increase the maximum travel in the direction that it controls, and turning it negative (-) will decrease the maximum travel. **For the adjustment screws on the side without the motor cable**, turning clockwise is positive (+) and counterclockwise is negative (-). **For the adjustment screws on the side with the motor cable**, turning clockwise is negative (-) and counterclockwise is positive (+)

3) To set a limit, run the motor in the selected direction.

4) If the motor stops on its own before reaching the desired stop, turn the appropriate limit screw positive. Every 2 to 3 turns of the limit adjustment screw will allow the motor to travel about 1 inch further. After every few turns of the limit adjustment screw, use the control switch to move the motor to the new limit position. (If the motor does not stop on its own before reaching the desired limit, go to step 6)

5) When you are approximately at the desired limit position, use the control switch to run the motor away from the limit 2 to 3 feet, and then back. This will allow you to see precisely where the limit is set. Make small adjustments and repeat.

6) If the motor does not stop on its own at least 6 inches before the desired limit position, stop the motor with the control switch. Then turn the limit adjustment screw in the negative direction. Confirm that the motor is stopped at the limit and set the limit as per steps 4 and 5. If the motor is not stopped at the limit, continue turning the limit adjustment screw. (up to 120 turns may be required)

NOTE: The motor has a built in thermal cutoff. If after several minutes of use the motor will not run in either direction, allow the motor to cool for approximately 20 minutes.

WIRING INSTRUCTIONS

WARNING

- Do not install any wiring or attempt to run the operator without checking the wiring diagrams first.
- Disconnect power before proceeding with any wiring.
- Do not turn on power until you have finished making all power and control wiring connections.
- The operator must be properly grounded. Failure to properly ground the operator could result in electric shock and serious injury or death.
- To avoid damage to the door and operator, make all door locks inoperative. Secure locks in the unlocked position, or install external electrical interlocks to prevent operation with the locks engaged.
(NOTE: external electrical interlocks should be provided only with a Smart Motor Control (SMC)).
- Do not change closing control from constant pressure to momentary pressure without installing a sensing edge. This could result in serious injury or death to person(s) trapped beneath the door.
- After installation, ensure that the operator, lock sensor, controls, and sensing edge or other entrapment protection devices have been tested and function properly.

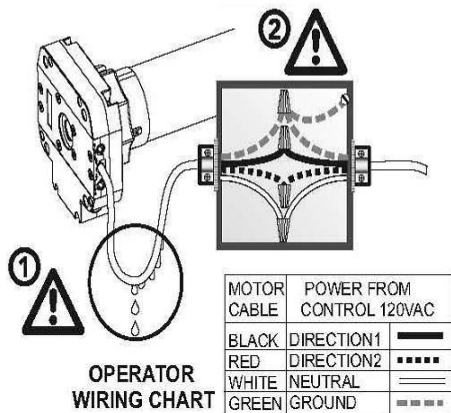
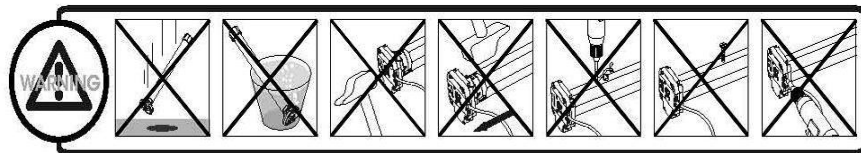

All wiring must conform to the National Electrical Code and local codes

- (1) The motor must be installed with a drip loop to prevent water intrusion
- (2) Connect the motor to power using a Listed junction box with appropriate cable strain reliefs.
- It is recommended a method of power disconnect for each motor be placed within sight of the motor to cut power during servicing.
- Do not use the motor cable to penetrate building walls. Connect the motor to power in a Listed junction box and from the Listed junction box run power in the manner proscribed by NEC and local codes.

1. TUBULAR MOTOR WITHOUT CONTROL PANEL

NOTICE: For installation by a qualified electrician in accordance with national and local electrical codes, and the following instructions.

CAUTION: RISK OF ELECTRICAL SHOCK. Disconnect power before installing. Never wire energized electrical components.

Select conductors having 90°C or higher rated insulation having sufficient ampacity in accordance with the 60°C column of National Electrical Code® Table 310-16 or Canadian Electrical Code Table 2

DO NOT USE TIN CONDUCTORS.

Warning

DO NOT wire more than one operator to a single pole switch. A second operator can be wired to the second pole of a double pole switch.

DO NOT connect two switches to an operator without a relay.

Wiring for one motor and one rocker switch

Power from wall

BLACK (120v - 60hz)

WHITE (neutral)

GREEN (ground)

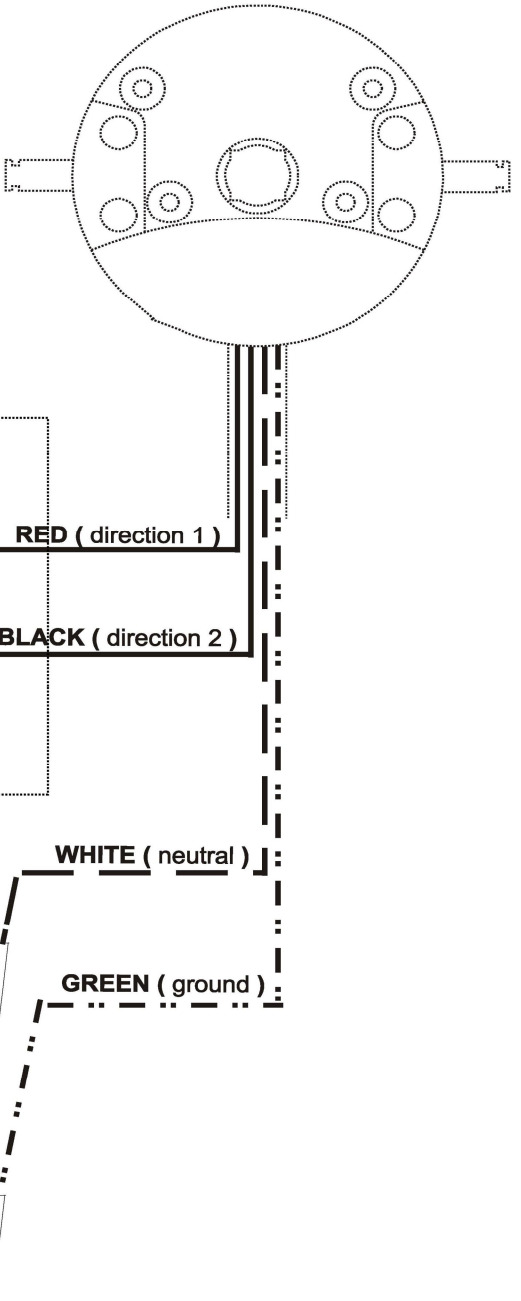

Power in		
Hot	Black	—————
Neutral	White	- - - - -
Ground	Green	- · - · - · - · - · - · - ·

Motor Leads		
Direction 1	Red	—————
Direction 2	Black	—————
Neutral	White	- - - - -
Ground	Green	- · - · - · - · - · - · - ·

Wiring for one motor and one designer switch

NOTICE: For installation by a qualified electrician in accordance with national and local electrical codes, and the following instructions.

CAUTION: RISK OF ELECTRICAL SHOCK. Disconnect power before installing. Never wire energized electrical components.

Select conductors having 90°C or higher rated insulation having sufficient ampacity in accordance with the 60°C column of National Electrical Code® Table 310-16 or Canadian Electrical Code Table 2

Terminal capacity: #14 AWG to #10 AWG

Strip conductors using strip gage on switch body. DO NOT USE TIN CONDUCTORS.

Warning

DO NOT wire more than one operator to a single pole switch. A second operator can be wired to the second pole of a double pole switch.

DO NOT connect two switches to an operator without a relay.

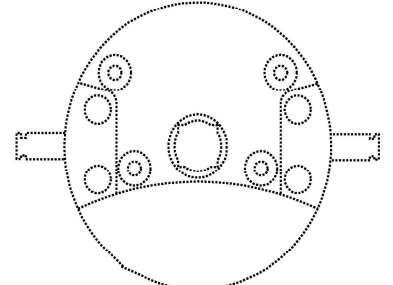

Power from wall

GREEN (ground)

BLACK (120v - 60hz)

WHITE (neutral)

GREEN (ground)

RED (direction 1)

BLACK (direction 2)

WHITE (neutral)

Power in		
Hot	Black	—————
Neutral	White	- - - - -
Ground	Green	- · - · - · - · - ·

Motor Leads		
Direction 1	Red	—————
Direction 2	Black	—————
Neutral	White	- - - - -
Ground	Green	- · - · - · - · - ·

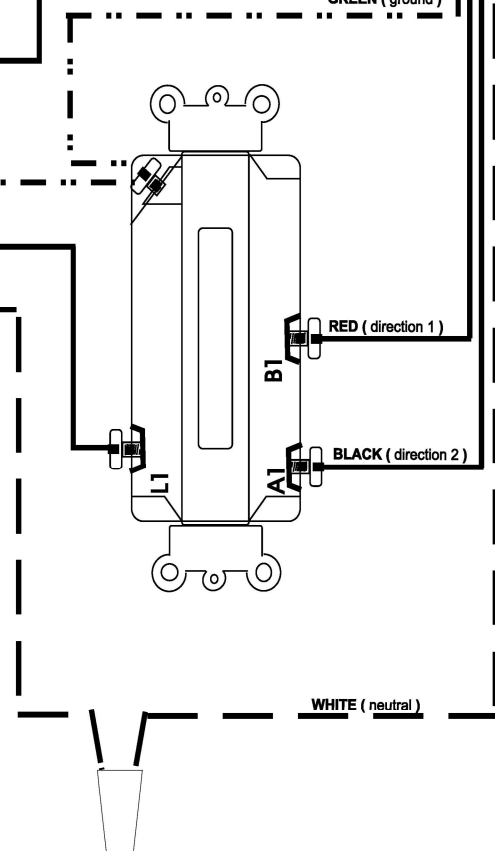

Wiring for one motor and one toggle switch

NOTICE: For installation by a qualified electrician in accordance with national and local electrical codes, and the following instructions.

CAUTION: RISK OF ELECTRICAL SHOCK. Disconnect power before installing. Never wire energized electrical components.

Select conductors having 90°C or higher rated insulation having sufficient ampacity in accordance with the 60°C column of National Electrical Code® Table 310-16 or Canadian Electrical Code Table 2

Terminal capacity: #14 AWG to #10 AWG

Strip conductors using strip gage on switch body. DO NOT USE TIN CONDUCTORS.

Warning

DO NOT wire more than one operator to a single pole switch. A second operator can be wired to the second pole of a double pole switch.

DO NOT connect two switches to an operator without a relay.

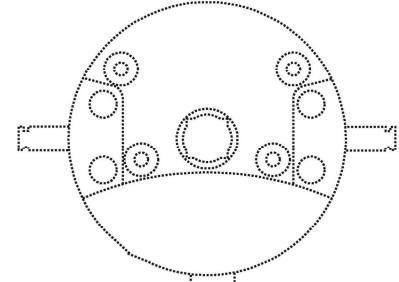

Power from wall

GREEN (ground)

BLACK (120v - 60hz)

WHITE (neutral)

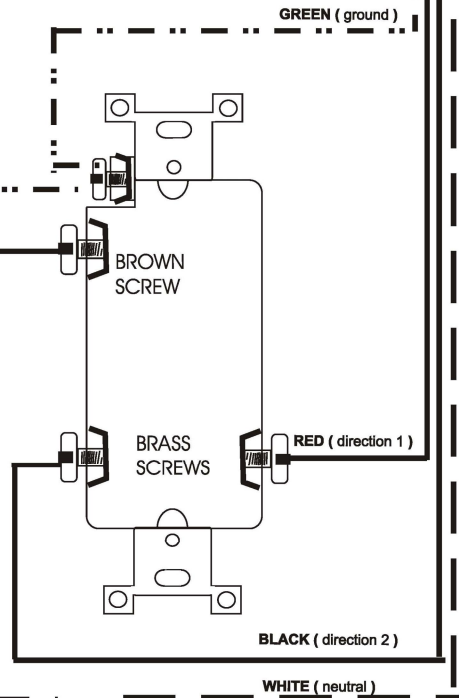

Power in		
Hot	Black	—————
Neutral	White	- - - - -
Ground	Green	- · - · - · - · - · - ·

Motor Leads		
Direction 1	Red	—————
Direction 2	Black	—————
Neutral	White	- - - - -
Ground	Green	- · - · - · - · - · - ·

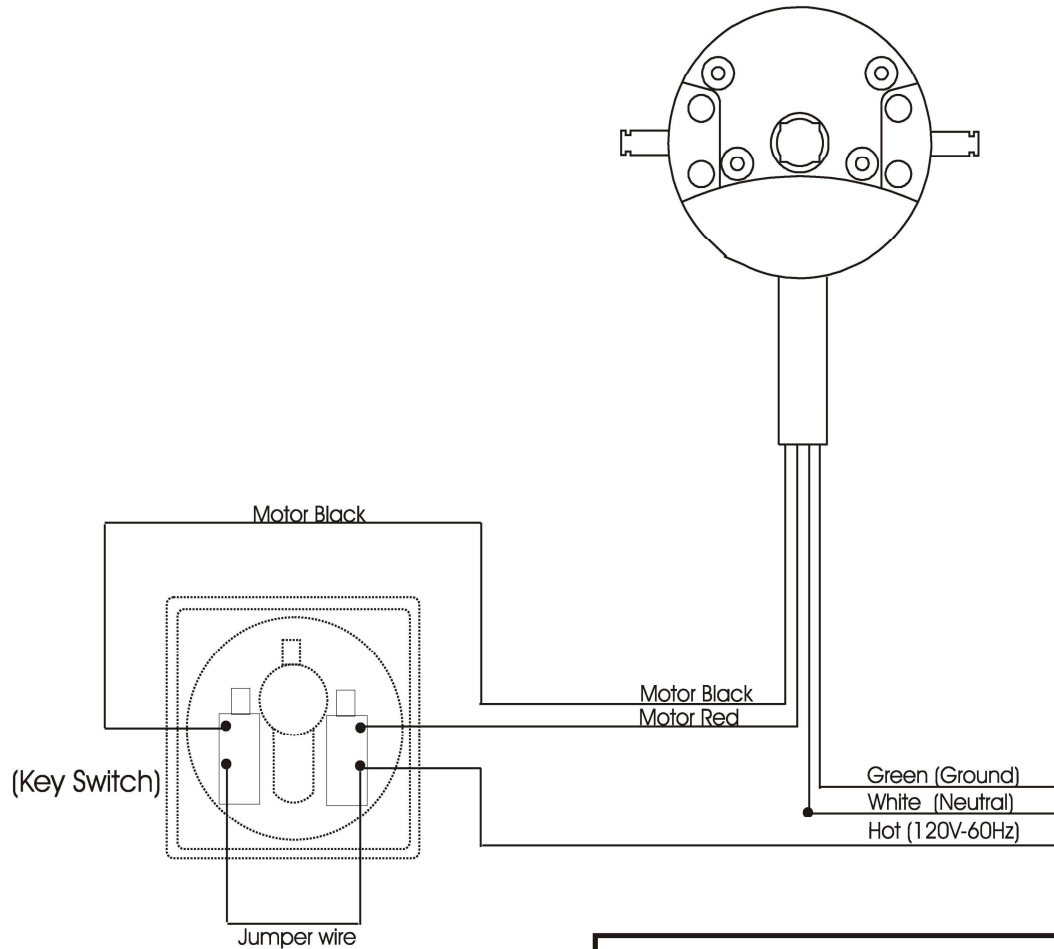

Key Switch

- * One Motor
- * One Key Switch

Reference Numbers

- 601201 - Momentary key switch, surface mount
- 601203 - Momentary key switch, recessed mount

NOTICE: For installation by a qualified electrician in accordance with national and local electrical codes, and the following instructions.

CAUTION: RISK OF ELECTRICAL SHOCK. Disconnect power before installing. Never wire energized electrical components.

Select conductors having 90°C or higher rated insulation having sufficient ampacity in accordance with the 60°C column of National Electrical Code® Table 310-16 or Canadian Electrical Code Table 2

DO NOT USE TIN CONDUCTORS.

Warning

DO NOT wire more than one operator to a single pole switch. A second operator can be wired to the second pole of a double pole switch.

DO NOT connect two switches to an operator without a relay.



NEW SMC SMART MOTOR CONTROL

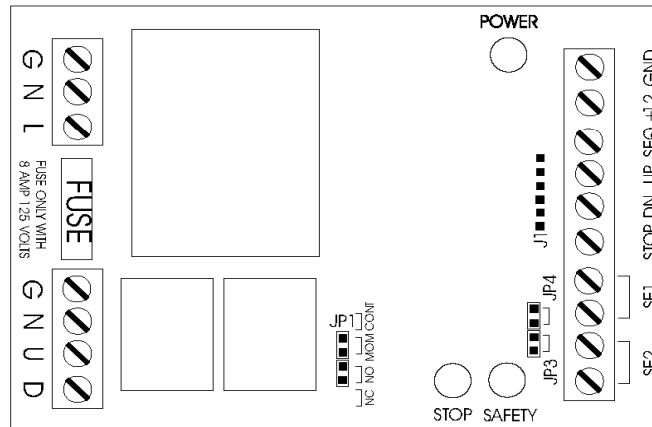

The "Smart Motor Control" (SMC) is an ideal general purpose intelligent control system for commercial or industrial applications. The SMC allows control of a 120VAC tube motor by most standard commercial controls and safety detectors.

FEATURES

- Mounts in standard 3 gang electrical box
- 250 mA 12 volt supply for accessories
- Diagnostic LEDs for quick, easy trouble shooting
- Supports normally open and close inputs from reversing detectors
- Supports 2 and 4 wire safety edges
- The stop button is selectable - normally open or normally close
- Control is selectable - timed run or continuous pressure
- Sequencing input supports single contact devices such as:
Radio Controls, Key Switches, Card Readers



SIMU U.S. INC
 6100 BROKEN SOUND PKWY. N.W., #14
 BOCA RATON, FL 33487
 PHONE: 800-822-7468 FAX: 561-995-7502

INSTALLERS MANUAL
 PAGE: 1 OF 5

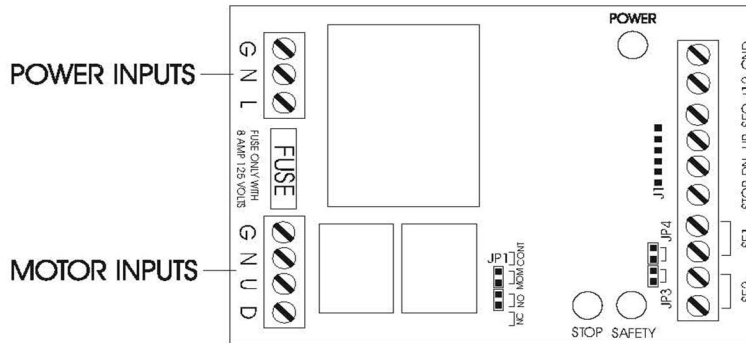

HIGH VOLTAGE CONNECTIONS

POWER INPUTS: G - GROUND
 N - 120 VAC NEUTRAL
 L - 120VAC HOT

MOTOR INPUTS: G - MOTOR GROUND (GREEN)
 N - MOTOR NEUTRAL (WHITE)
 U - MOTOR UP (BLACK*)
 D - MOTOR DOWN (RED*)

*IF MOTOR RUNS IN WRONG DIRECTION, REVERSE THE RED AND BLACK MOTOR WIRES

JUMPERS

RUN TIME JUMPER JP1 (TOP)



JUMPER ON (MOM)

WITH THE JUMPER ON, THE RUN TIMER IS OFF AND THE SMC WILL DRIVE THE MOTOR ONLY AS LONG AS THE UP OR DOWN BUTTON IS PRESSED

NOTES:

- 1) THE REVERSING DETECTOR CONTROLS ARE DEACTIVATED IN THIS MODE.
- 2) THE SEQUENCING CONTROL IS DEACTIVATED IN THIS MODE.
- 3) THIS MODE CAN BE USED TO CLOSE THE DOOR IF THERE IS A MALFUNCTION IN THE REVERSING DETECTORS. THIS MUST ONLY BE DONE IF THE UP/DOWN SWITCH IS IN DIRECT VIEW OF THE DOOR. THE REVERSING DETECTORS MUST BE SERVICED AS SOON AS POSSIBLE AND THE DOOR RETURNED TO ITS NORMAL OPERATING MODE.





JUMPER OFF (CONT)

WITH THE JUMPER OFF, THE RUN TIMER IS ACTIVE AND THE SMC WILL DRIVE THE MOTOR FOR 1 MINUTE (OR TO THE MOTOR LIMIT) WHEN THE UP OR DOWN BUTTON IS PRESSED. PRESSING THE OTHER DIRECTION WHEN THE MOTOR IS RUNNING WILL CAUSE THE MOTOR TO STOP FOR 1/4 SECOND BEFORE REVERSING DIRECTIONS.



NOTES:

- 1) THE SMC MUST BE IN THIS MODE FOR THE SEQUENCING AND REVERSING DETECTORS TO BE ACTIVE.

STOP SELECT JUMPER JP1 (BOTTOM)

 <p>JUMPER ON (N.O.)</p> <p>WITH THE JUMPER ON, THE STOP BUTTON IS SELECTED NORMALLY OPEN (N.O.). A CLOSED STOP CONTACT WILL STOP THE MOTOR AND LIGHT THE YELLOW STOP LED.</p> <p>NOTES: 1) THE JUMPER MUST BE IN THIS POSITION IF A STOP SWITCH IS NOT USED OR IF THE STOP BUTTON IS N.O.</p>	 <p>JUMPER OFF (N.C.)</p> <p>WITH THE JUMPER OFF, THE STOP BUTTON IS SELECTED NORMALLY CLOSE (N.C.). A OPEN STOP CONTACT WILL STOP THE MOTOR AND LIGHT THE YELLOW STOP LED</p> <p>NOTES: 1) THE JUMPER MUST BE IN THIS POSITION IF A N.C. STOP SWITCH IS USED. LEAVING THE JUMPER ON WITHOUT A N.C. STOP BUTTON ATTACHED WILL CAUSE THE SMC TO NOT OPERATE.</p>
--	---

REVERSING DETECTOR JUMPERS (JP3 JP4)

 <p>JUMPERS OFF (4 WIRE EDGE)</p> <p>BOTH JUMPERS JP3 AND JP4 MUST BE OFF TO USE A 4 WIRE SENSING EDGE.</p> <p>NOTES: 1) IF EITHER JUMPER IS OFF WITHOUT A 4 WIRE SENSING EDGE ATTACHED, THE RED SAFETY LED WILL LIGHT AND THE DOOR WILL BE LOCKED IN THE UP DIRECTION.</p>	 <p>JUMPERS ON (2 WIRE EDGE OR N.O. DETECTOR)</p> <p>BOTH JUMPERS JP3 AND JP4 SHOULD BE ON IF A NORMALLY OPEN REVERSING SENSOR IS USED OR IF NO REVERSING SENSOR IS USED.</p> <p>NOTES: 1) IT IS STRONGLY RECOMMENDED THAT A REVERSING SENSOR BE USED IF THE SMC RUN TIMER IS ON.</p>
 <p>1 JUMPER ON, 1 JUMPER OFF (N.C. DETECTOR)</p> <p>WITH JUMPER JP3 ON AND JP4 OFF A NORMALLY CLOSE REVERSING SENSOR CAN BE CONNECTED TO SE1.</p> <p>NOTES: 1) WITH JP4 OFF A NORMALLY CLOSE CONTACT MUST BE CONNECTED TO SE1 OR THE SMC WILL LOCK THE DOOR OPEN.</p>	

LOW VOLTAGE SWITCHING CONNECTIONS

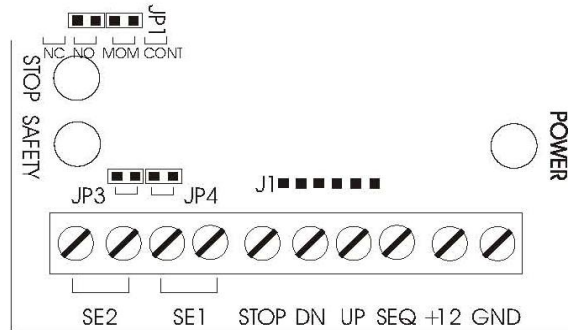

3 BUTTON STATION

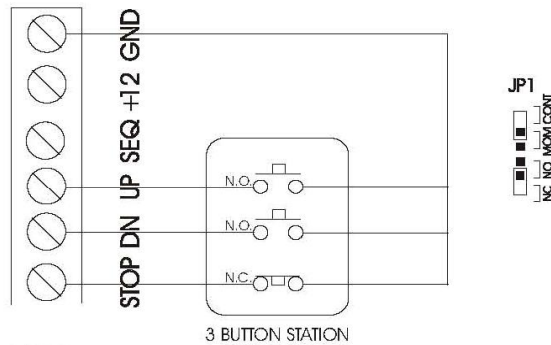

- NOTES:
- 1) SHOULD BE USED WITH REVERSING SENSORS
 - 2) SHOWN CONFIGURED FOR A N.C. STOP BUTTON

2 BUTTON STATION

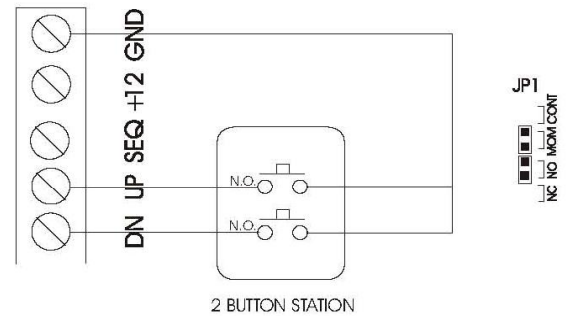

- NOTES:
- 1) SHOWN REQUIRING CONSTANT PRESSURE ON THE SWITCH FOR THE MOTOR TO OPERATE.
 - 2) SWITCH MUST BE IN VIEW OF THE DOOR

SEQUENCING CONTROL

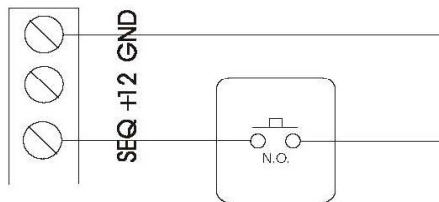

- NOTES:
- 1) CAN BE USED WITH ANY MOMENTARY, DRY CONTACT SUCH AS KEY SWITCHES, CARD READERS, RADIO CONTROLS, ETC..
 - 2) TWO OR MORE SWITCHES CAN BE WIRED IN PARALLEL.
 - 3) CONTROL WILL FOLLOW A SEQUENCE WITH EACH PULSE (UP, STOP, DOWN, STOP, UP,

SINGLE CHANNEL RADIO

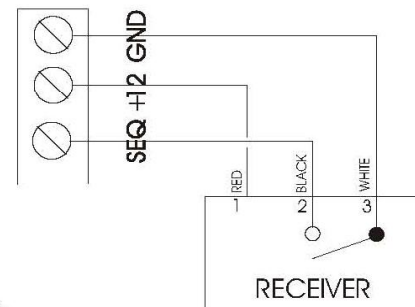

- NOTES:
- 1) WIRING SHOWN IS STANDARD BUT MAY VARY WITH MANUFACTURER. CHECK INSTRUCTIONS WITH RADIO RECEIVER FOR DIFFERENCES BEFORE WIRING.

4 WIRE SENSING EDGE

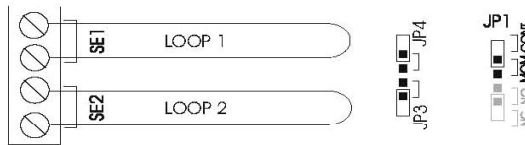

- NOTES:
- 1) JUMPERS JP3 AND JP4 MUST BE OFF WHEN USING A 4 WIRE SENSING EDGE.
 - 2) JP1 TOP JUMPER MUST BE OFF (CONT). THIS SETS THE SMC RUN TIMER ON.
 - 3) JP1 LOWER JUMPER SETTING DEPENDS ON STOP BUTTON.
 - 4) CHECK SENSING EDGE FUNCTION. IF THE MOTOR REVERSES UPON SENSING EDGE ACTIVATION WHEN THE DOOR IS GOING UP INSTEAD OF DOWN, REVERSE THE RED AND BLACK MOTOR LEADS.

N.O. SENSING EDGE (2 WIRE)

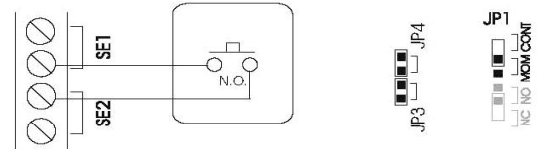

- NOTES:
- 1) JUMPERS JP3 AND JP4 MUST BE ON WHEN USING A NORMALLY OPEN SENSING (2 WIRE) EDGE.
 - 2) JP1 TOP JUMPER MUST BE OFF (CONT). THIS SETS THE SMC RUN TIMER ON.
 - 3) JP1 LOWER JUMPER SETTING DEPENDS ON THE STOP BUTTON.
 - 4) CHECK SENSING EDGE FUNCTION. IF THE MOTOR REVERSES UPON SENSING EDGE ACTIVATION WHEN THE DOOR IS GOING UP INSTEAD OF DOWN, REVERSE THE RED AND BLACK MOTOR LEADS.

N.C. REVERSING SENSOR

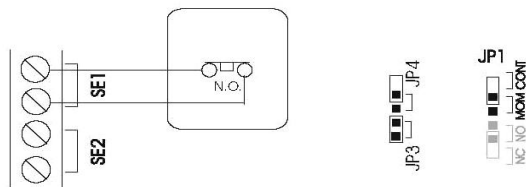

- NOTES:
- 1) JUMPER JP3 MUST BE ON AND JP4 MUST BE OFF WHEN USING NORMALLY CLOSE REVERSING SENSOR.
 - 2) JP1 TOP JUMPER MUST BE OFF (CONT). THIS SETS THE SMC RUN TIMER ON.
 - 3) JP1 LOWER JUMPER SETTING DEPENDS ON STOP BUTTON.
 - 4) CHECK SENSING EDGE FUNCTION. IF THE MOTOR REVERSES UPON SENSING EDGE ACTIVATION WHEN THE DOOR IS GOING UP INSTEAD OF DOWN, REVERSE THE RED AND BLACK MOTOR LEADS.

INTERLOCK (KEYED LOCK OUT)

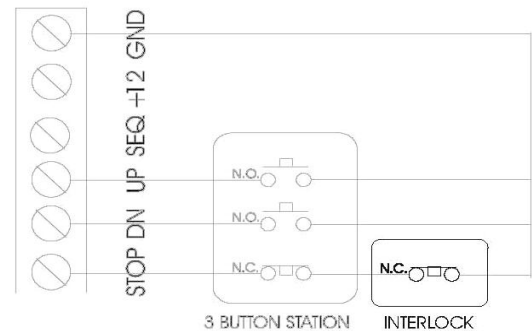

- NOTES:
- 1) A NORMALLY CLOSED INTERLOCK (KEYED LOCK OUT) CAN BE CONNECTED IN SERIES WITH THE N.C. STOP BUTTON.
 - 2) SHOULD BE USED WITH REVERSING SENSORS
 - 3) SHOWN CONFIGURED FOR A N.C. STOP BUTTON.

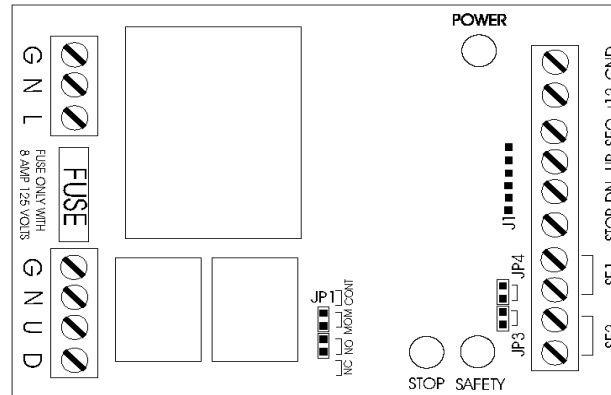

ELECTRICAL RATINGS

INPUT POWER: 120V AC 60Hz

MOTOR OUTPUT MAXIMUM: 8AMPS

FUSED: 8AMP 125V

LOW VOLTAGE SUPPLY FOR OFF BOARD CONTROLS: 12VDC @250mA

DIAGNOSTIC LED'S

GREEN POWER LED ON - POWER AND FUSE CONNECTIONS ARE GOOD

YELLOW STOP LED ON - ACTIVE STOP SIGNAL (CONTROL IS LOCKED)

RED SAFETY LED ON - ACTIVE REVERSING DETECTOR SIGNAL. (CONTROL WILL LOCK DOOR IN OPEN DIRECTION)

TROUBLE SHOOTING

PROBLEM - NO RESPONSE FROM CONTROL

- 1) IF THE GREEN POWER LED IS NOT ON: CONFIRM THAT THERE IS 120VAC ON THE POWER INPUT AND THAT THE CONNECTIONS ARE CORRECT.
CHECK THE FUSE.
- 2) IF THE GREEN POWER AND YELLOW STOP LEDS ARE ON: CHECK THAT THE STOP JUMPER IS CONFIGURED CORRECTLY.
CHECK CONNECTIONS TO THE STOP BUTTON.
- 3) IF THE GREEN POWER LED IS ON AND THE YELLOW STOP AND RED SAFETY LED'S ARE OFF: CHECK THE CONNECTIONS TO THE MOTOR.
TEST THE MOTOR DIRECTLY WITH A TEST SWITCH.
CHECK THE MOTOR LIMITS (TURN BOTH LIMITS PLUS 5 REVOLUTIONS).

PROBLEM - MOTOR LOCKED IN ONE DIRECTION

- 1) IF THE RED SAFETY LED IS ON: CHECK THE CONNECTIONS TO THE REVERSING DETECTORS.
CONFIRM THAT THE JUMPERS JP3 AND JP4 ARE CONFIGURED CORRECTLY.
- 2) IF THE RED SAFETY LED IS NOT ON: CHECK THE CONNECTIONS TO THE MOTOR.
CHECK THE MOTOR LIMIT (TURN IT PLUS 5 REVOLUTIONS).
TEST THE MOTOR DIRECTLY WITH A TEST SWITCH.

PROBLEM - MOTOR RUNS ONLY AS LONG AS SWITCH IS HELD DOWN

THIS IS CORRECT OPERATION IF REVERSING DETECTORS ARE NOT USED. IF REVERSING DETECTORS ARE USED, CHECK THE POSITION OF THE RUN TIME JUMPER (JP1 TOP).

OPERATING INSTRUCTIONS

Tubular motors have a built-in thermal cut-off. If, after several minutes of use, the motor will not run in either direction, allow the motor to cool for approximately 20 minutes.

A. Constant Pressure Control

1. To open the door press/turn the switch up. Releasing the switch will cause the door to stop. If a key switch is used, turn the key to the "UP" position to open the door. Release the key and the door will stop.
2. To close the door press/turn the switch down. Releasing the switch will cause the door to stop. If a key switch is used, turn the key to the "DOWN" position to close the door. Release the key and the door will stop.

B. Momentary Pressure Control

1. If a 3-button control station is used to operate the door, push the "OPEN" button to open the door, push the "CLOSE" button to close the door, push the "STOP" button to stop movement of the door while opening or closing.
2. If a key switch control station is used to operate the door, turn the key to the "OPEN" position to open the door, turn the key to the "CLOSE" position to close the door, push the "STOP" button to stop movement of the door while opening or closing.

WARNING – DO NOT USE MOMENTARY PRESSURE CONTROL WITHOUT INSTALLING A SENSING EDGE. THIS COULD RESULT IN SERIOUS INJURY OR DEATH TO PERSON(S) TRAPPED BENEATH THE DOOR.

WARNING – IF THE DOOR IS NOT VISIBLE FROM THE CONTROL STATION A SENSING EDGE MUST BE INSTALLED ON THE BOTTOM OF THE DOOR. FAILURE TO INSTALL A SENSING EDGE MAY RESULT IN SERIOUS INJURY OR DEATH TO PERSON(S) TRAPPED BENEATH THE DOOR.

EMERGENCY MANUAL OPERATION

Tubular motors are equipped with an integrated manual override. To manually operate the door use the winding shaft provided.

On non-rated counter doors, the manual override allows you to open or close the door in case of a power failure.

NOTE: On rated counter doors, the manual override is operable only if the electromagnetic clutch of the release mechanism located at the opposite end of the barrel is engaged.

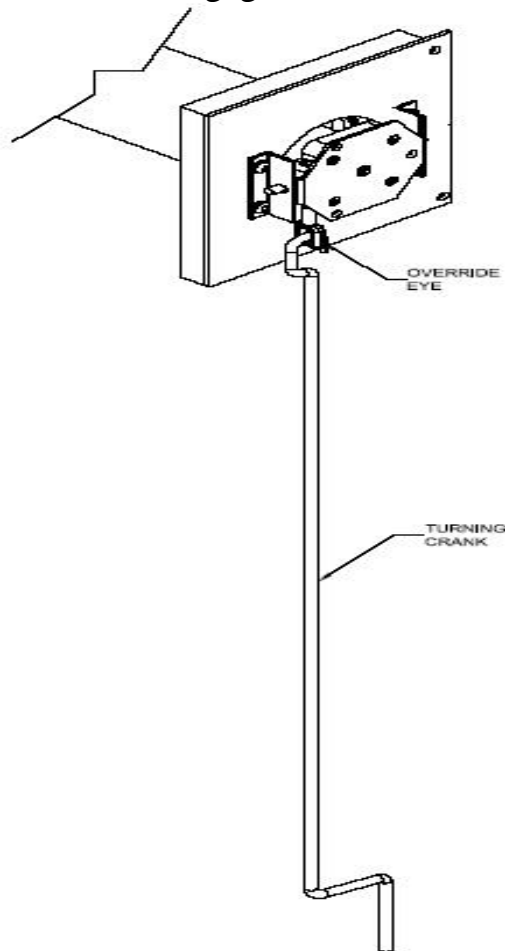

SAFETY INSTRUCTIONS

WARNING – To reduce the risk of severe injury or death:

1. Read and follow all instructions.
2. Never let children operate or play with door controls.
3. Personnel should keep away from a door in motion and keep the moving door in sight until it is completely closed or open. **NO PERSON SHOULD CROSS THE PATH OF A MOVING DOOR.**
4. Test the door's safety features at least once a month. Re-adjust travel limits if necessary. Failure to adjust the operator properly may cause severe injury or death.
5. Save these instructions for reference.

MAINTENANCE INSTRUCTIONS

WARNING – Disconnect power supply to the operator before servicing.

1. Inspect and service whenever a malfunction of either door or operator is observed or suspected.
2. Before servicing, always disconnect power supply to the operator.
3. All replacement parts must be compatible with those originally provided.
4. If an entrapment protection device is used, i.e. sensing edge, please consult the manufacturer for maintenance instruction.

WARNING – Do not place hands or tools in or near the operator when the power is connected or when testing control or safety devices. Always disconnect power before servicing the operator.