

Installation Instructions, Extreme Microcoil Grille

Section 1 - Table of Contents





Section 2 – Safety Check List	1
Section 3 – Freight Receiving	2
Section 4 – Pre-installation	3
Section 5 – Guides	4
Face Of Wall	4
Section 6 – Barrel and Brackets	6
Preparation	6
Hoisting and Installing Barrel Assembly	7
Section 7 – Motor Operator Installation	9
Section 8 – Sensor Mounting	11
Section 9 – Hood, Fascia, and Covers	13
Hood Support Installation	13
Hood and Fascia Installation	14
Horizontal Motor Cover	17
Vertical Motor Cover	17
Section 10 – Torque Specifications	18
Section 11 – Maintenance Schedule	19
Section 12 – Curtain Repair	21
Appendix A – Extreme® MicroCoil Grille Construction and Maintenance	24

Section 1 - Table of Contents

Rolling doors are large, movable objects. They move with the help of electric motors or manual operators (chain, crank, push up, etc), and most have springs under high tension. These items and their components can cause injury. In order to avoid injury to yourself and others, please follow the instructions in this manual.

- **Review the potential hazards and preventative measures listed below:**

Table 2.1 - Potential Hazards and Preventative Measures

Potential Hazard	Preventative Measure	
	<p style="text-align: center;">⚠ DANGER</p> <p style="text-align: center;">Pinned or crushed by closing door.</p>	<ul style="list-style-type: none"> • Keep yourself and others clear of opening while door is in motion. • Do not allow children to play near or operate door. • Do not operate if door becomes jammed or broken.
	<p style="text-align: center;">⚠ WARNING</p> <p style="text-align: center;">Struck by adjusting wheel bar while applying spring turns.</p>	<ul style="list-style-type: none"> • Be sure bar is adequate in strength and long enough to allow installer to apply the necessary torque. • Make sure bar is fully seated into the adjusting wheel slot before applying pressure. • Use two bars while applying turns to the adjusting wheel.
	<p style="text-align: center;">⚠ WARNING</p> <p style="text-align: center;">Electrical shock.</p>	<ul style="list-style-type: none"> • Make sure electrical operator is properly grounded. • Turn off source power completely prior to servicing the motor. • Make sure wires are clear of any moving or potentially moving parts. • Avoid pinching wires when installing the motor cover.
	<p style="text-align: center;">⚠ WARNING</p> <p style="text-align: center;">Pinched by moving components.</p>	<ul style="list-style-type: none"> • Make sure the motor is turned off and unplugged before working with moving parts such as roller chain and sprockets, drop-out mechanisms, adjusting wheels, etc. • Locate the possible pinch-points of the unit (Drive chain, coil area, bottom bar, etc.). Do not operate the door while someone is near these areas.

- **Check the following during installation and before leaving the job site:**
 - a. If the unit has tension springs, be sure the proper amount of tension is applied to the torsion springs, in order to properly counterbalance the weight of the curtain.
 - b. Securely fasten the tension adjusting wheel in place with the appropriate hardware provided.
 - c. Check that the keys and/or cotter pins have been set in place and fit properly at all sprockets or gears.
 - d. Check that the setscrews in each sprocket or gear (one over the key and one offset from the key) have been tightened properly.
 - e. Check all fasteners holding the unit to the building structures.
 - f. Check all fasteners used to assemble the components of the unit together.
 - g. Instruct owner or representative in the proper method of operating the door.

Section 3 – Freight Receiving

- **Upon delivery, check condition of components for damage.**
- **If damage occurred in transit, the installation should not proceed without authorization.**

NOTICE

If the installation proceeds, neither the carrier nor the manufacturer will assume responsibility for replacing the damaged material.

- **If the installation is stopped due to damage, do the following:**
 1. Take pictures of the damage.
 2. Do not move material from point of delivery to other premises once the damaged components are discovered.
 3. Do not unpack, if the damage is visible prior to removing packaging, until an inspection is made.
 4. If the damage is found while removing contents from packaging, the packaging material must be saved until inspection is made.
 5. Container and packaging should be retained by consignee until inspection is made.
 6. Have components inspected by carrier's representative within 15 days from date of delivery.
 7. Consignee must obtain a copy of the Inspection Report.
- **Returning damaged components:**
 1. Obtain permission from carrier to return.
 2. Route the return shipment via the identical carrier(s) involved in the original shipment.
 3. Notify the manufacturer when shipment is returned to manufacture plant.
- **Verify that all components have arrived. Look for the following:**
 1. Job construction drawings featuring different views (elevation, section, plan, etc.)
 2. (2) Guide assemblies; check for guide weathering if included in order
 3. Packaged Barrel assembly, curtain assembly with bottom bar, and (2) Bracket assemblies.
 4. Operator.
 5. Operator mounting assembly.
 6. Operator cover; may not be included in order.
 7. Hood and hood supports; may not be included in order.
 8. Hardware.
 9. Misc. items (Reelite, lintel seal, hood baffle, etc.).
 10. Verify material/finish/color of components matches what is listed on the job construction drawings and/or what was ordered.
- **If the delivery is incomplete:**
 1. Make note on delivery receipt.
 2. Note should be verified by driver's signature.
 3. Notify carrier and manufacturer.

Section 4 - Pre-installation

- **Read entire instruction manual thoroughly. The manufacturer will not be held responsible for any charges incurred due to improperly installed components.**
 - a. Only trained door systems technicians should perform installation, maintenance, etc.
 - b. Each unit comes with an individual item number. If the job contains multiple units, be sure to locate all the components for each item and separate each.

⚠WARNING

Do not interchange parts from one door to another.

- c. Find the job construction drawings for the unit being installed and check the dimensions of the opening against those on the drawings. See **Figure 4.1** below.
- d. If the opening dimensions differ from those on the drawings, **do not proceed**, check with distributor/manufacturer to be sure the correct door is being installed.
- e. Check the jambs of the opening for plumb. Check the head/lintel and floor for level. If the unit is to be free standing, for example mounted to tubes, check the floor and ceiling for level and for adequate mounting areas at the top and bottom.
- f. If your guides are embedded please contact the Service Department at 1-800-233-8366 for additional warning labels to be applied to finished wall. Ask for "Safety Instruction Labels."

Note: *The floor may not be level if a pitched bottom bar is specified.*

- **Work Area:**
 - a. The key to a smooth installation is a clean and well-prepared work environment. Once the components have been inspected and the job construction drawings have been reviewed; lay out the components in the order of installation.
 - b. The opening for the door should be cleaned and inspected for rough surfaces and construction debris.
 - c. Lastly the mounting hardware supplied with the door should correspond with the surface and construction features of the opening.
 - d. The basic assembly sequence is as follows:
 1. Guides.
 2. Packaged Barrel, curtain with bottom bar and Bracket assembly.
 3. Motor operator (if applicable).
 4. Weather stripping (if applicable).
 5. Hood, and operator/adjustor/idler covers (if applicable).

Figure 4.1 - Opening Dimensions and Designations

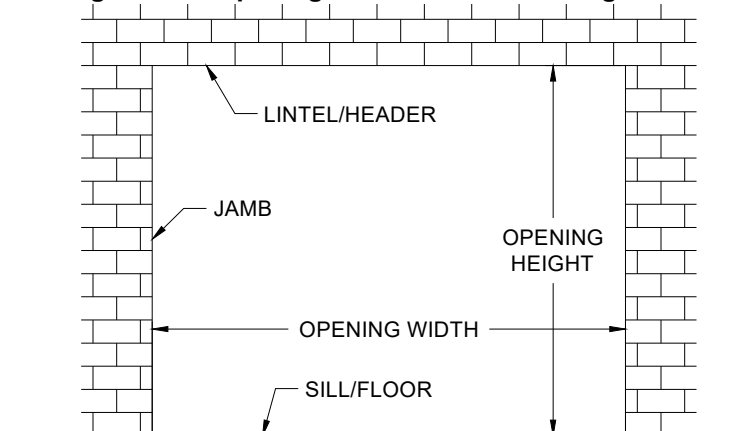

Section 5 - Guides

▪ **Face of Wall Units (Figures 5.1 - 5.2):**

Note: Determine which guide assemblies are utilized on the unit from the job construction drawings and compare to the diagrams below.¹

Figure 5.1 – Face of Wall “E” Guide

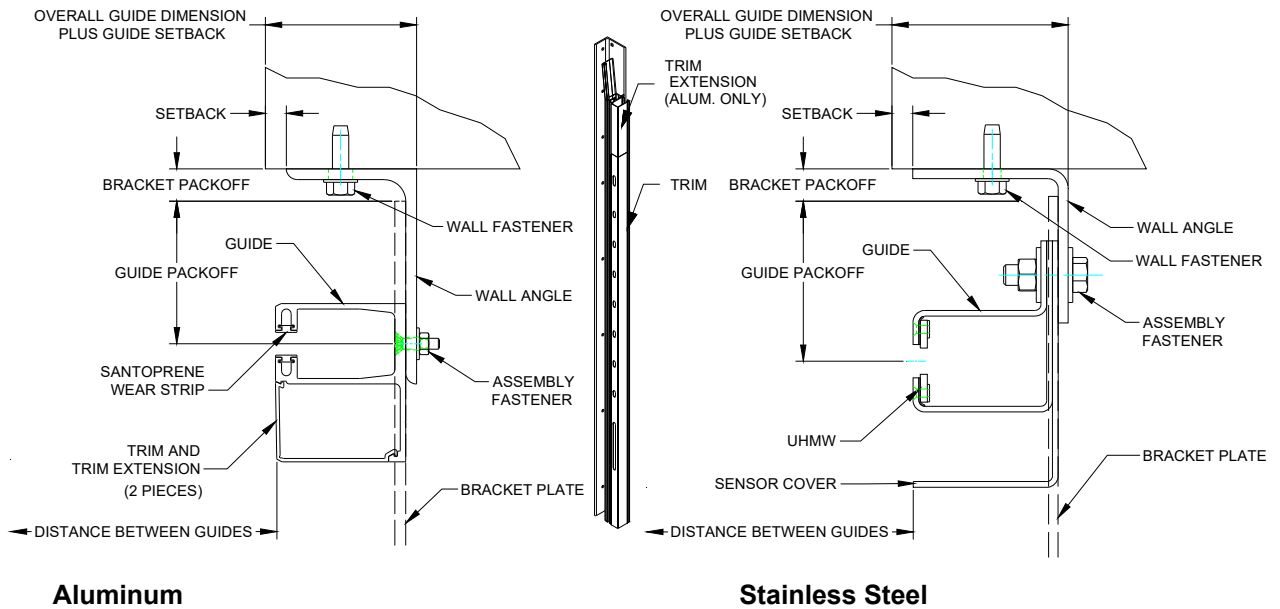
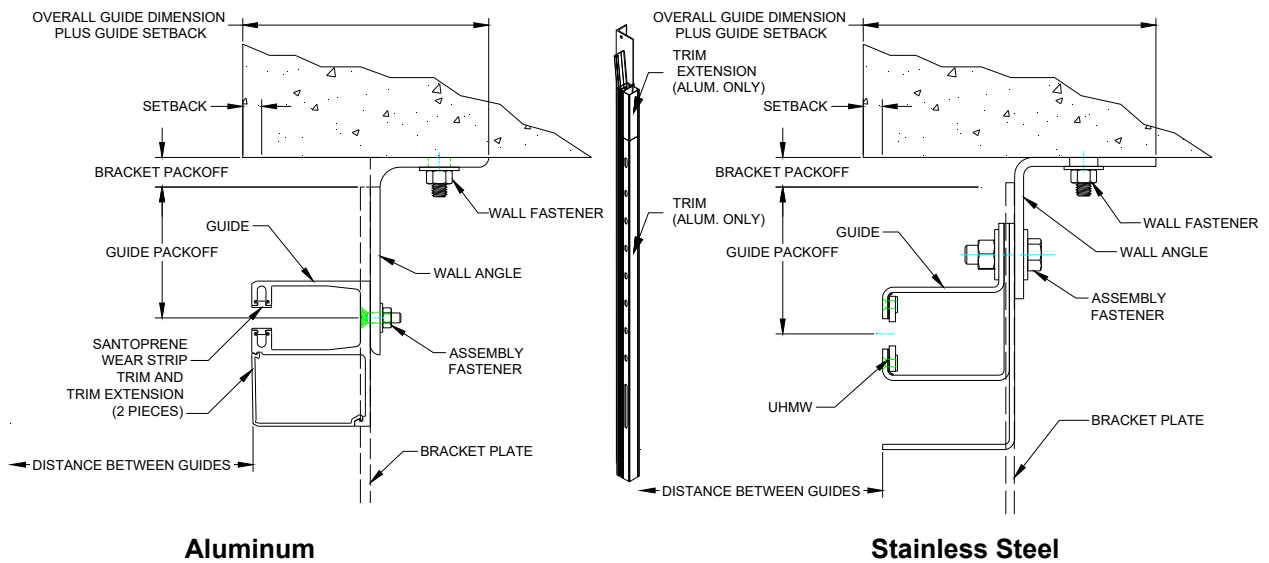

Figure 5.2 – Face of Wall “Z” Guide



¹ The guide assembly may differ from the right to left hand side of the unit. In these cases, follow the directions for each particular guide assembly, as well as the job construction drawings provided with the unit.

Section 5 - Guides

1. Separate the trim, trim extension and guide from the wall angle if necessary for aluminum models. The aluminum trim can be unsnapped, out of the guide by pressing on location "A" (see figure 5.3). To snap the trim into the guide, clip the longer leg into the guide, across the entire length (location "B", figure 5.3). Starting from the bottom, hold location "B" in place and exert force on the edge of the shorter leg, section "A", until the trim snaps/clicks into the guide. Start snapping the trim from the bottom and progress upwards. On stainless steel guides, the stainless steel sensor cover can be disassembled, by removing the assembly bolts.

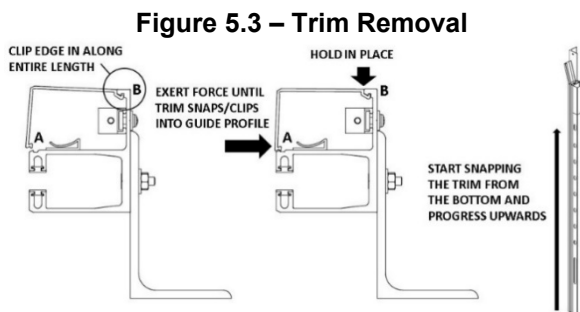

2. Measure the distance from the opening/jamb to the heel of the wall angle (on "E" guides) or the toe of the wall angle (on "Z" guides). This distance is referred to as the "Overall Guide Dimension plus Guide Setback"; see **Figures 5.1** and **5.2**. See the job construction drawings for the guide setback and overall guide dimensions.
3. Place mark on the floor at measured location. Check the distance between these marks and compare with the job construction drawing. It will be the "Opening Width" plus "Overall Guide Dimension" plus "Guide Setback" at both jambs.

NOTICE

If the measurement does not equal the dimensions on the job construction drawings, **STOP**. Check the guide dimensions against those on the job construction drawings to be sure the correct guides are being installed. If so, repeat previous step and re-check.

4. Scribe a plumb line on the wall from the marks on the floor.
5. Place the guide or wall angle against the scribed line, check the top of the guide for level, and mark the location of the wall fastener mounting holes.
6. If the wall angle is attached to the wall with fasteners, drill mounting holes for the wall fasteners and fasten the wall angle with the hardware provided. Check the job construction drawings for the wall fastener required. Tighten the wall fasteners to the recommended installation torque in the *Torque Specifications Tables* in **Section 10**.
7. If the wall angle is attached to the wall by welding to structural steel, see the job construction drawings for details on weld location, type, pitch, size, etc.¹

NOTICE

When installing a door with a pitched bottom bar it may be helpful to put the curtain into the guide before securing the guide to the wall angle. This is particularly helpful if there is a large slope and low headroom available.

8. At this point, the aluminum guide extrusion or inner/outer stainless steel guides and cover can be reassembled to the wall angle using the hardware provided. For aluminum models it is not necessary to snap the trim into place at this time. Tighten to recommended installation torque in the *Torque Specification Tables* in **Section 10**.

¹ Minimum recommended weld rod: AWS A5.1, Grade E-70.

Section 6 – Barrel, Curtain and Brackets

Preparation of the Barrel, Curtain and Brackets

Note: Check to see if a hood support will be required. If so, refer to the “**Hood Support Installation**” section before proceeding to the barrel and brackets.

1. Determine which jamb wall is your “operator side”, or side on which the operator is to be installed. The following instructions refer to these directional cues.
2. The Barrel, Curtain, and Brackets will come from the factory assembled and packaged on a skid. The packaging can be removed only after the brackets are secured to the wall angles and the motor is installed. Note the markings on the packaging, see **Figure 6.1** below.

Figure 6.1 – Assembly Markings

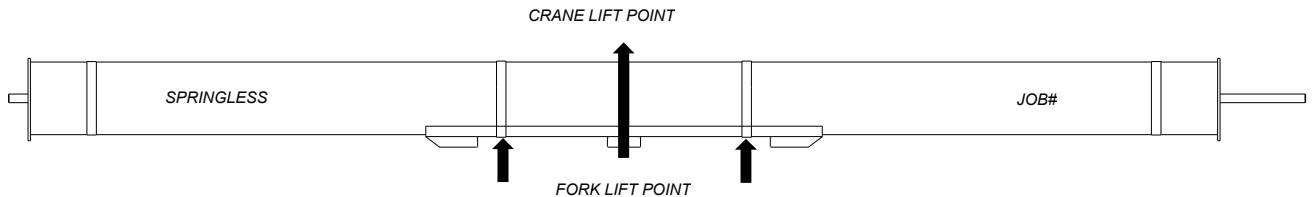

3. Locate the brackets. Determine the “operator” and “adjustor” brackets by referring to **Figure 6.2**. The “operator” bracket will contain a bearing and holes to mount the operator. The “adjustor” bracket will contain a bearing only.

Figure 6.2 – Barrel Spacer Installation

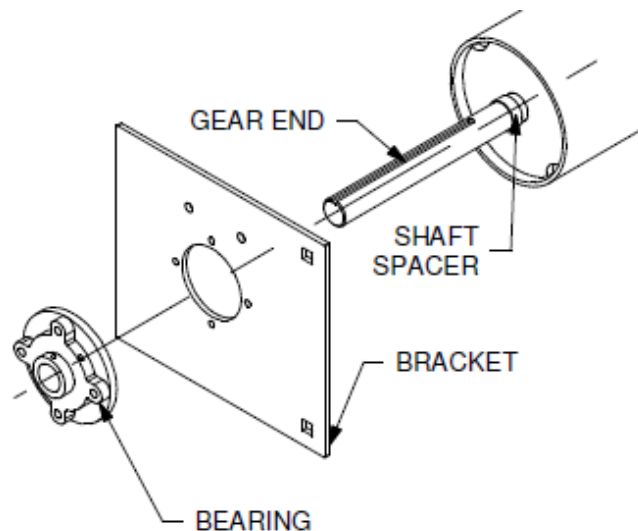

4. Remove the tape off the shaft spacers and slide them towards the gear end plate leaving 1/8” between the spacer and the weld.
5. Slide the operator and adjustor brackets over the gear end until the inside face of the bracket is approximately 0.6875 (11/16) inches from the edge of the outer shaft. Do not tighten the set screws at this point, as you may need to adjust the position of the bracket.
6. Position and center the assembly between the guides on the coil side of the opening with the end with the longer gear end towards the “operator side” of the opening.
7. Check to make sure the packaging is marked as *springless*, as shown in **Figure 6.1**. Consult the distributor or the manufacturer if you cannot locate this information.

Section 6 – Barrel, Curtain and Brackets

Figure 6.3 – Brackets and Barrel Prior to Installation

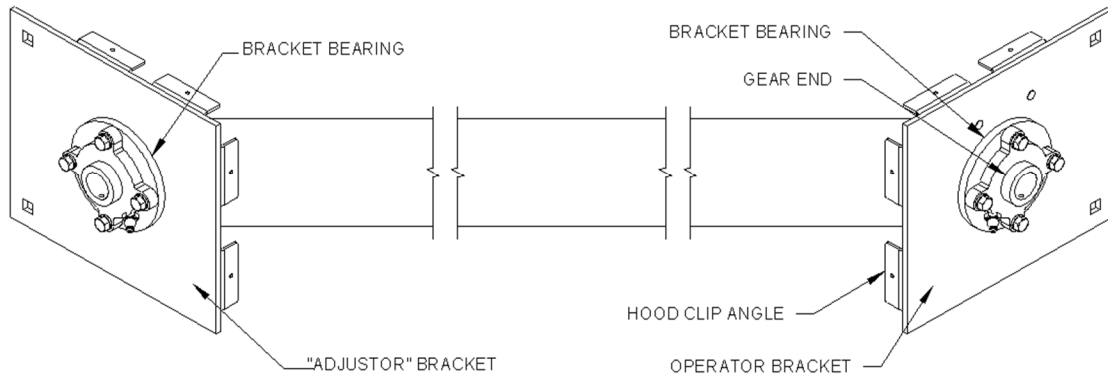

▪ Hoisting and Installing Barrel/ Curtain/ Bracket Assembly

1. The following methods can be used for hoisting them into place:
 - **Crane Hoisting:** Place a sling or lifting agent under the barrel assembly at the “lift point” provided on the barrel, see **Figure 6.1**.
 - **Forklift Hoisting:** Space the forks evenly under the “lift point” provided on the barrel, see **Figure 6.1**. Ensure that the barrel assembly is positioned close enough to the tips of the forks that the fastening holes in the bracket can be aligned with those of the guides without the forks contacting the wall. Secure the barrel assembly to prevent slipping off the tip of the forks.

⚠ WARNING

The operator may be installed prior to hoisting. If so, the addition of the operator may offset the balance slightly from when the “lift point” was marked. Check to make sure the assembly is properly balanced before hoisting.

2. Before hoisting, refer to the hardware sheet and ensure that the proper type and quantity of fasteners were provided for the bracket installation. Measure the distance between the brackets and compare that to your wall angles. Readjust the brackets as needed before hoisting.
3. Center the barrel assembly between the guides, keeping approximately 2 feet of clearance between the packaged assembly and wall/guides.
4. Raise the barrel assembly up to the approximate bracket mounting level. The brackets should be clear of the outer and inner guide angles.

Note: Position the brackets in the upright position, with the mounting holes facing the wall, before moving the assembly towards the wall. It may be difficult to rotate the bracket when in close to the wall.

Slowly maneuver the barrel assembly towards the guide, and align the mounting holes of the brackets with those of the wall angles.
5. Insert the specified bolts and snug tighten, see **Figure 6.2**.

Section 6 – Barrel, Curtain and Brackets

Figure 6.4 – Bracket Mounting Configuration and Hardware

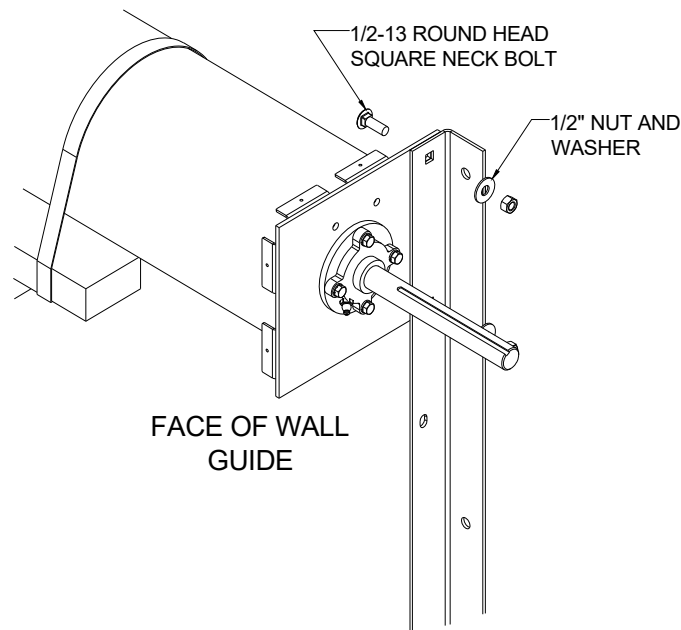

6. Check to see that the barrel is positioned properly between the brackets. That is, so that the proper amount of space is allowed between the barrel and the brackets. The space is equal at both the operator and adjustor side. Adjust as necessary. The set screws in the bearings should be tightened at this time.
7. Place a level in the center of the barrel and curtain assembly. If the assembly is **not** level:
 - Check the dimensions of the brackets from the top of the bracket to the center of the barrel.
 - Verify that the bracket mounting fasteners are the same distance from the top of the bracket.
 - a. If the dimensions **are not** correct, contact the Service Department.
 - b. If the dimensions **are** correct, the floor may be out of level, causing the bracket mounting holes in the guides to be out of alignment.
8. Install the Operator. **See section 7.**
9. After the motor is installed the packaging can be dismantled by cutting the steel bands. Use caution when disassembling the skids.
10. Remove the curtain packaging (cardboard, bubble wrap), except for the fiber tape.
11. Position the bottom bar so it is in line with the guides and remove the fiber tape.
12. Use the operator to lower the bottom bar into the guides and operate the door until it reaches the closed position or until you have access to the barrel surface.
13. Place a level in the center of the barrel to verify if the barrel is level otherwise repeat step 7.
14. Fully tighten mounting brackets bolts to the torque specifications in this manual. See *Torque Specification Tables* in **Section 10**.

NOTICE

Proper pretension of the bracket mounting bolts will benefit the life of the bolts and brackets.

Section 7 – Motor Operator Installation

1. Unpack the motor operator from the shipping box and retrieve the mounting plates and hardware provided.
2. Refer to the shop drawings in order to understand the operator mounting configuration. See **Figure 7.1** for a vertical mount configuration or **Figure 7.2** for a horizontal mount configuration.
3. Attach the gearbox mounting plate to the operator using the provided hardware. Do not tighten the bolts at this time.
4. In the unlikely event of the operator needing to be removed for maintenance in the future, anti seize lubricant has been provided. Prior to installation apply the anti seize lubricant to the gear end, Gib key, and inside hub of the operator.
5. Place the Gib key in the keyway of the gear end. Slide the operator over the gear end of Gib key, ensuring the keyways are aligned. The keyways can be aligned by rotating the barrel by hand or utilizing the auxiliary hand chain on the operator.
6. Align the operator and mounting plates so that the operator hangs freely on the gear end.
7. Tighten all the bolts at this time.
8. Attach the operator mount to the head plate.
9. Remove the bolt in the front/top of the gearbox housing and install the provided vent plug. See **Figure 7.3**.

NOTICE

Installation of the vent plug is critical to safe operation of the operator. Failure to install the vent plug may cause permanent damage to the operator.

Figure 7.1 – Vertical Motor Mount

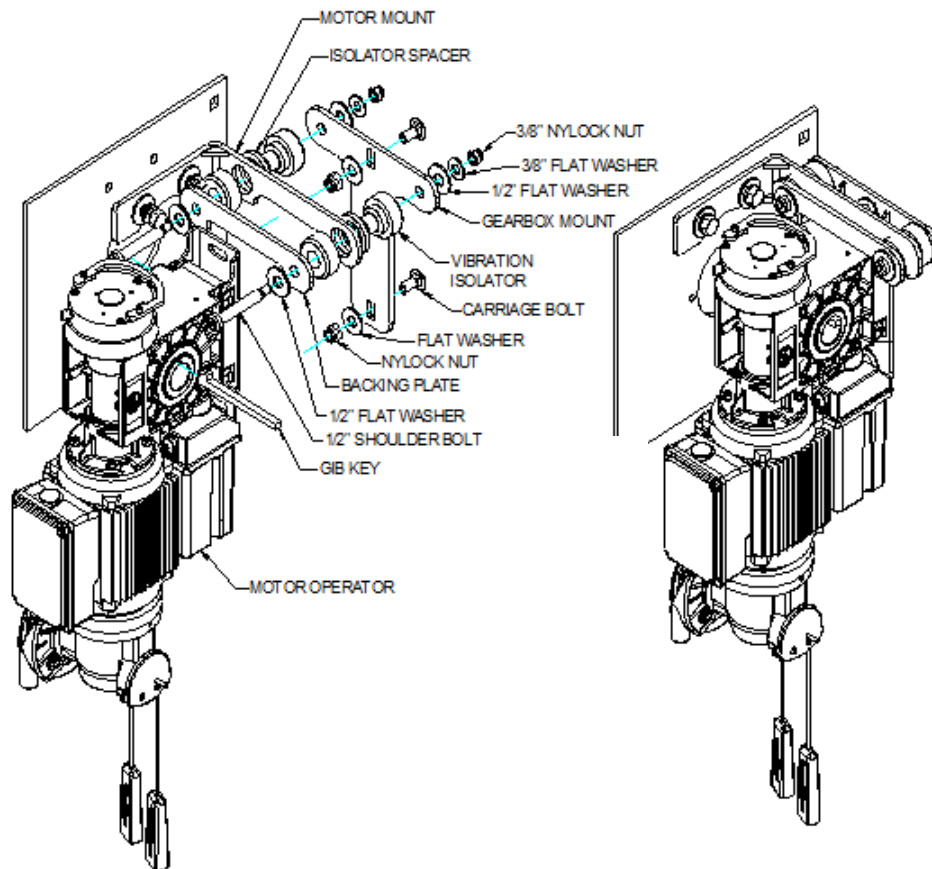

Section 7 – Motor Operator Installation

Figure 7.2 – Horizontal Motor Mount

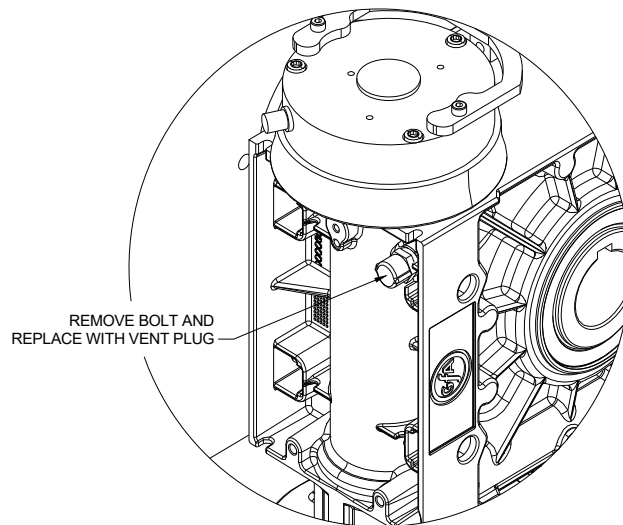
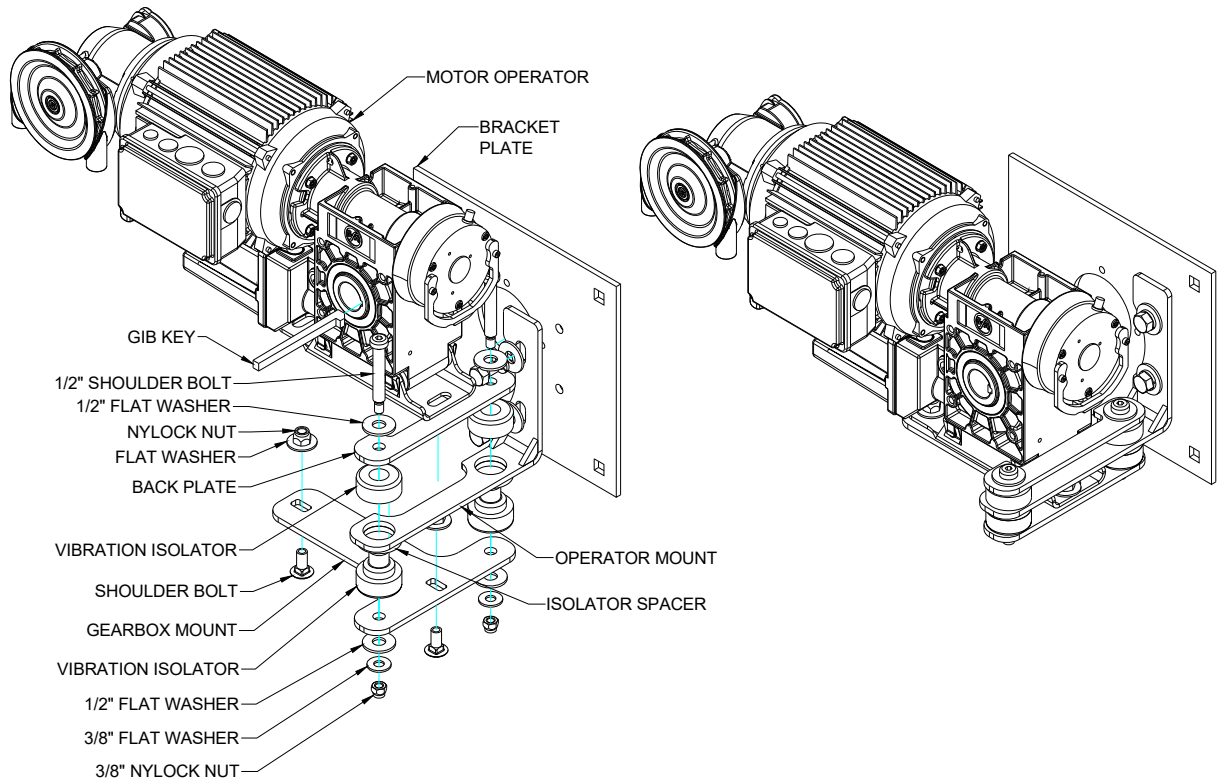

Figure 7.3 – GEARBOX HOUSING BOLT LOCATION

Section 8 – Sensor Mounting

▪ Sensor Mounting

1. Locate all sensors, mounts, hardware and wiring (pre-wired to the control panel). The light curtains are pre-installed into the guide assembly and the photoeyes are pre-installed onto the guides.
2. Ensure that the proper photoeyes and light curtains are placed on the proper side of the door. The photoeye transmitter (identified by “SMT” in the part number or the red housing) and the light curtain receiver (identified by “SGR” in the part number) will be placed on the “operator” side of the door. The photoeye receiver (identified by “SMR” in the part number of the yellow housing) and the light curtain transmitter (identified by the “SGT” in the part number) will be placed on the “adjustor” side of the door.
3. Route the plug and play cable through the access hole in the guide as shown in figure 8.1

Figure 8.1 – Photoeye Assembly

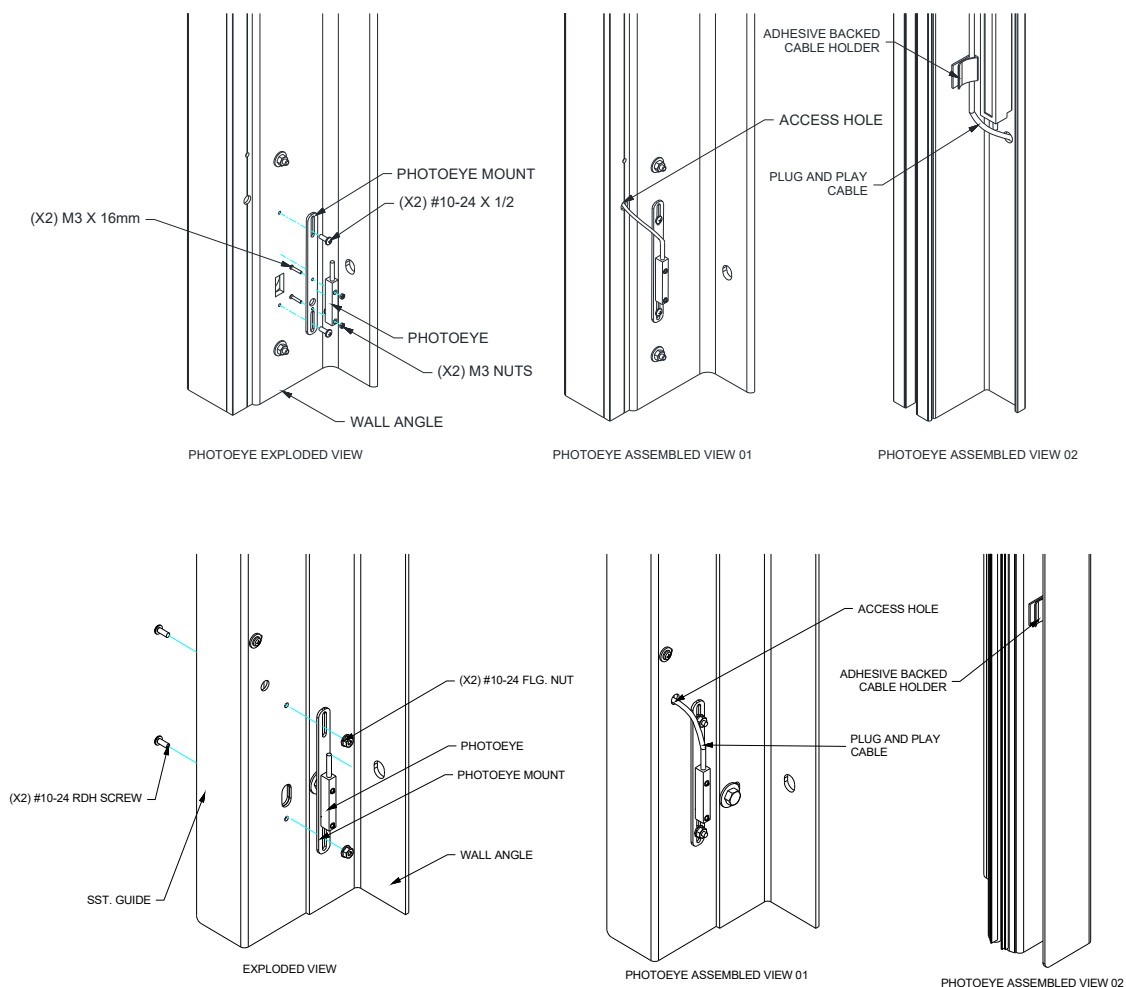

Section 8 – Sensor Mounting

- The light curtain is tensioned in place using 2 screws (pre-assembled). Verify the location of the Light curtain and Photoeyes using figure 8.2.

Figure 8.2 – Photoeye Assembly

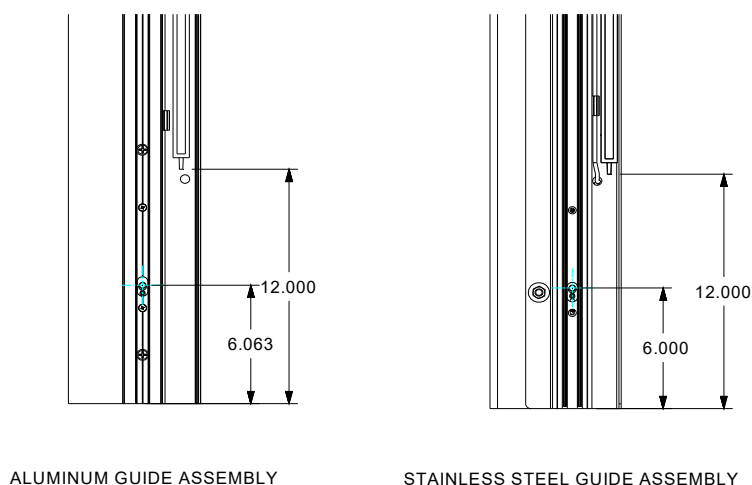

- Once the sensors are secured to the guides, route the plug and play connectors from the control panel to each side of the door. Use the access holes at the top of the guides to run wiring through the trim/ cover (Figure 8.3). Secure the wire to the guides using the provided clips. It is important that the cables are run in a manner such that they will not interfere with the sensors.

Figure 8.3 – Header Guide Access Holes

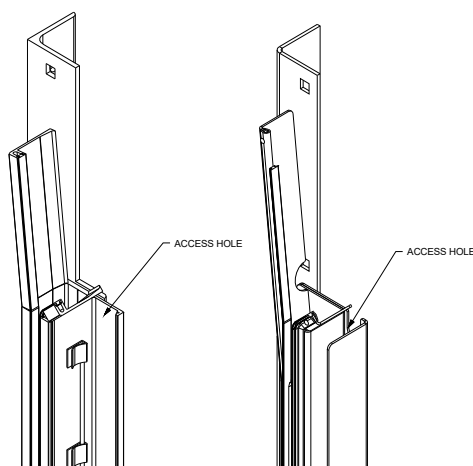

- If there is excessive cable within the guides, the excess cable can be zip tied and secured within the guides using the adhesive clips or cable managed outside the header guide access hole.
- If power is available, it is recommended to check the alignment of the sensors at this time prior to installing the guide trim. A laser level can be used to align the light curtains in the X,Y, and Z axis; it is critical for operation that the light curtains are level for communication.
- Install the slotted guide trim at the bottom and the trim extension directly above it as shown in figure 5.1 / 5.2.

⚠ WARNING

Check that the Bottom Bar Flag is installed prior to commissioning the door. (Flag is installed at Factory) Flag must be installed or permanent damage to the door may occur.

Section 9 – Hood, Fascia, and Covers

▪ Hood Support installation:

1. Refer to the job information to determine the type and quantity of hood supports required for your door. Hood supports will be noted on the elevation view of the job construction drawings. See **Figure 9.1** for hood support types.

Figure 9.1 - Hood Supports

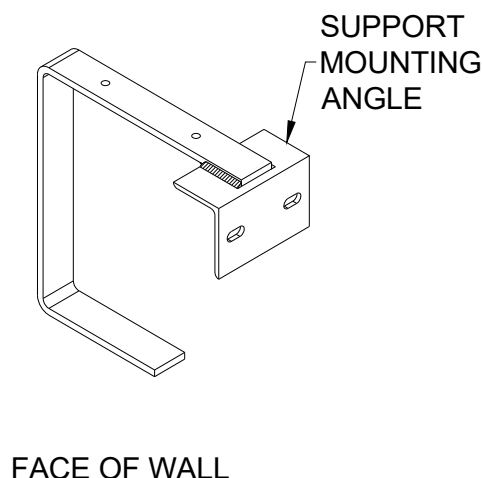

2. Determine where the support(s) will be located between the guides.
 - a. If multiple supports are required, see the job construction drawings to determine the centerline of each.
 - b. If a single support is required, it will be located at the center of the unit.
3. Mark a line on the lintel or ceiling (for units without a lintel) at the centerline of each support.
4. Check the construction at the support locations to be sure it is strong enough to handle the weight of the hood.

Note: *If the construction is not strong enough, do not proceed until rectified.*

5. The term “top of the coil” refers to the top edge of the brackets and hood which house the curtain (The curtain in the fully open position is referred to as the “coiled curtain”. The top of the coiled curtain is not actually located at the “top of the coil”, it is lower than the top of the coil) Locate the “top of the coil”:
 - a. This is typically at the top of the wall angle or intermediate angle.
 - b. If there is a ceiling at the top of the coil, skip the next step.
 6. Mark a line at the top of the coil at both guides of the unit. Project the lines together to make a continuous line.
 - a. This will help locate the top of the hood support which will keep the hood level.
 7. If there is no lintel/header, the hood support will be located based on the fascia side of the guide.
 8. Project a line from the fascia mounting location from one guide to the other.
 9. Mark a line at the support centerline along the fascia line.
 10. Prepare the location of the attachment point of the support(s) prior to installing the barrel. This will make installing the support much easier when the time comes to attach it to the lintel/header or ceiling.
 - a. Hold the support in place at the determined location and mark the mounting hole locations.
 - b. Drill holes in the construction.
 11. Attach the hood support to the lintel/header or ceiling to be sure the mounting holes were located properly.
 12. Remove the hood support and proceed to the **“Barrel and Brackets”** section.
- Once the barrel, brackets, and curtain are installed (and necessary testing was done on the unit), re-install the hood support.

Section 9 – Hood, Fascia, and Covers

▪ Hood and Fascia installation:

1. Determine what type of hood is provided. See **Figure 9.2** for possible hood configurations. This can be done by:
 - Looking at the brackets and identifying a half-circle shaped flat (D-shaped hood) or straight flats (square or sloped).
 - Looking in the hood box and comparing to the job construction drawings.

Figure 9.2 – Hood Configurations

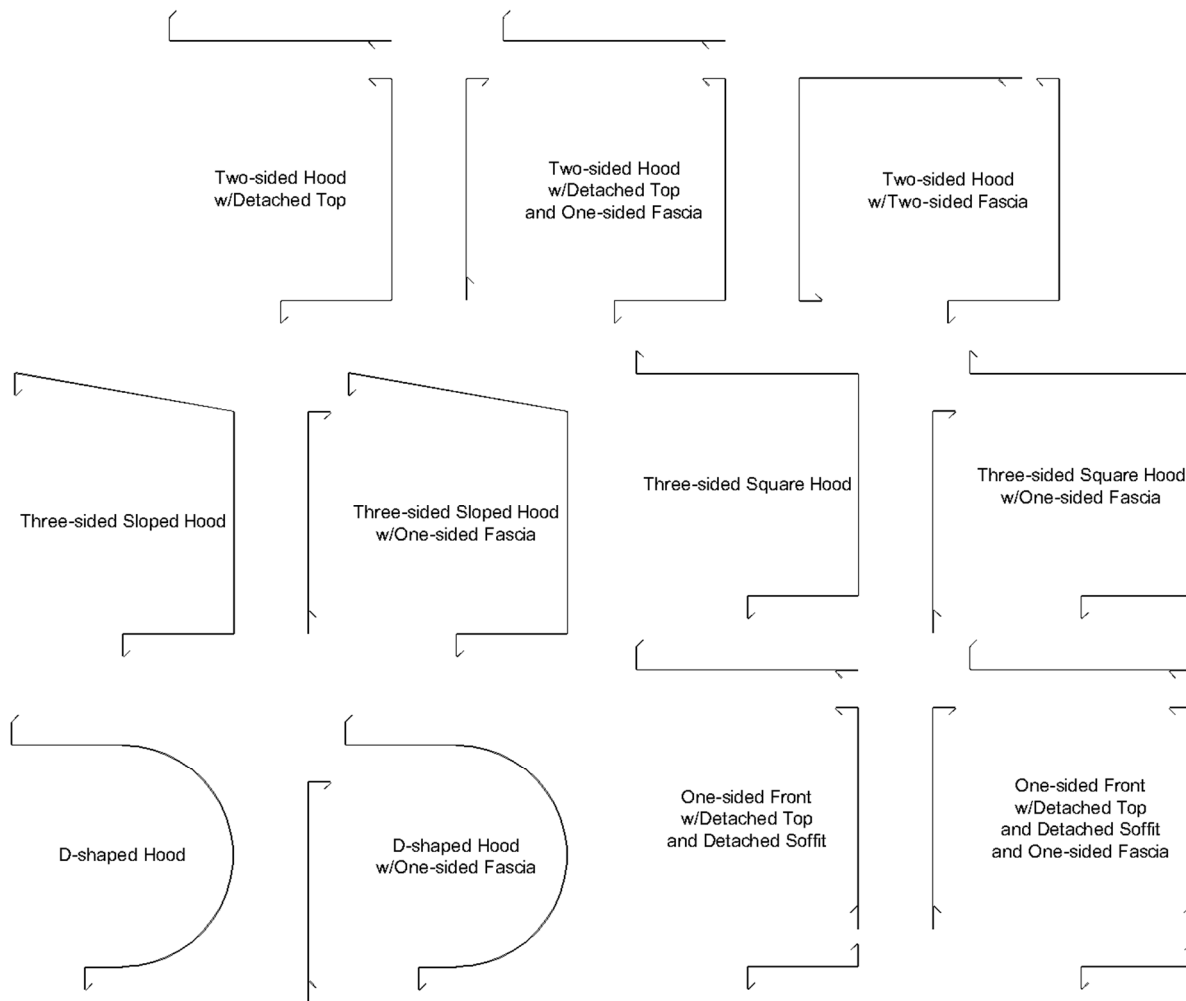

2. If no fascia is included, skip to Step 3.

If a fascia is included, it will be installed first. Fascia fastening varies by job condition but is typically secured to the guides, the brackets, or to the wall. Install the right-most section first, ending in “-R”. Continue leftward adding fascia sections, overlapping the right-hand section by 4”

3. If the hood has more than one section (separate left, right, or center), skip to Step 5.

For single-section hoods, begin with the front-most piece. Install by holding the hood up to the coil area and pushing it against the flats on the brackets. Center the hood so the gap is the same at both

Section 9 – Hood, Fascia, and Covers

brackets. Pre-drill with a #21 or 5/32" drill in at least one place on every face of the hood, at both the left and right sides. See **Figure 9.4** for recommended fastener locations.

4. After fastening the first hood piece, continue with the detached soffit and top, if included.
5. For hoods with multiple sections, begin with the front-most right-hand hood piece, ending in "-R".

Install by holding the hood up to the coil area and pushing it against the flats on the brackets. Butt the hood piece against the bracket to minimize the gap. Pre-drill with a #21 or 5/32" drill in at least one place on every face of the hood, at both the left and right sides. See **Figure 9.4** for recommended fastener locations.

The hood section should cover the hood support completely (approx. 4"). Temporarily clamp hood section to hood support until the next section is installed.

6. Continue leftward installing sections of the same type of hood piece before starting with the right-most soffit or top pieces. See **Figure 9.3** for an example of the order hood pieces should be installed. No cover is used on the splice between hood sections.

Figure 9.3 – Multiple Hood Sections

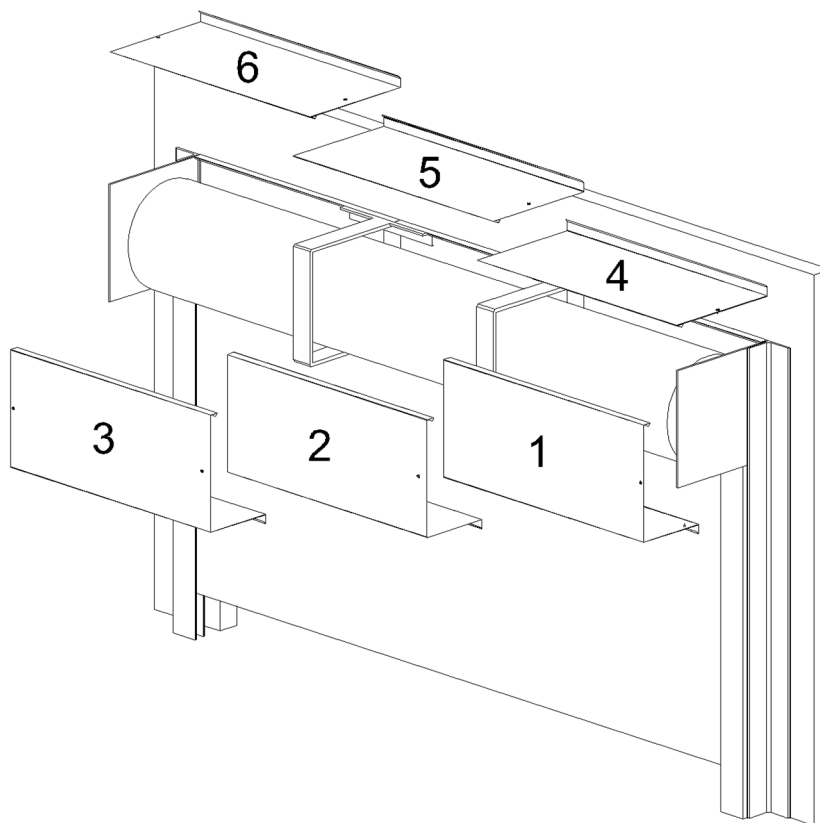

Section 9 – Hood, Fascia, and Covers

Figure 9.4 – Recommended Fastener Locations

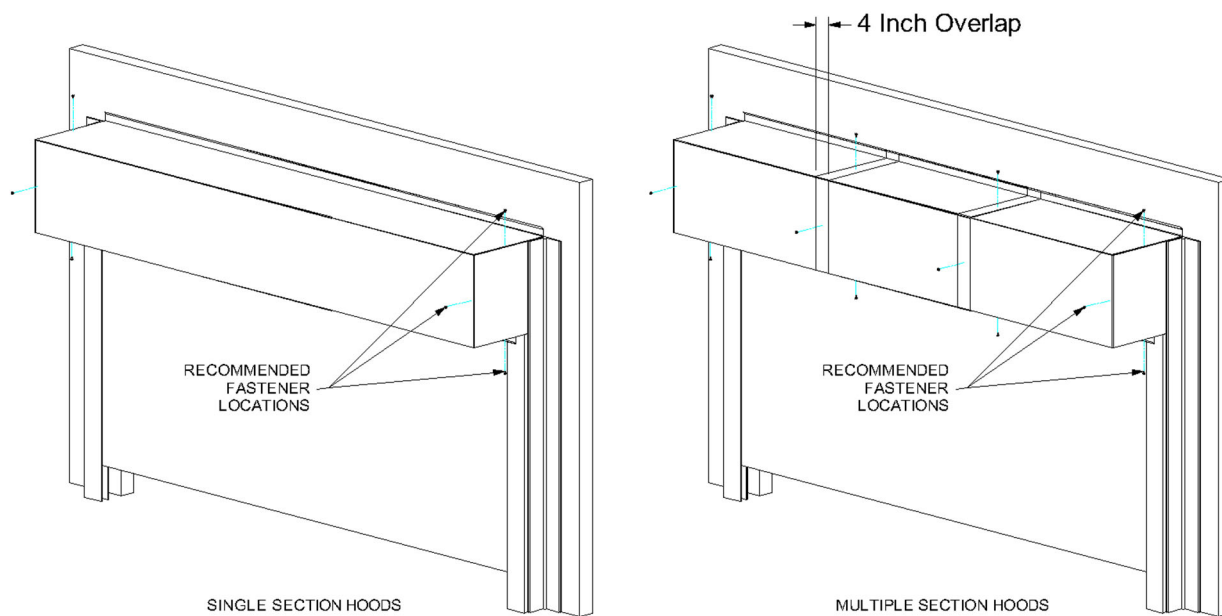

7. If the door is mounted in a weathered or exterior location, caulk the part of the hood that contacts the wall.

▪ **Hood Cover installation:**

1. Once the unit is installed and operating correctly, the covers can be installed.
2. Hood screws may have to be removed and reinstalled to install covers properly.
3. If the cover mounts to the side of the door bracket, pre-drill holes in the bracket to ease installation. A #21 drill size is recommended.
4. If an operator or adjustor cover is provided, individual installation instructions are provided with each cover along with the necessary hardware to attach the cover.
5. Once the cover is installed, operate the door a few more times to be sure there is no interference between the moving components inside the cover and the cover itself.
6. If the door is mounted on the exterior of the building, a bead of silicone sealant should be applied around the entire perimeter of the cover, as it will provide additional protection to the door components.

Figure 9.5 – Horizontal and Vertical Motor Cover

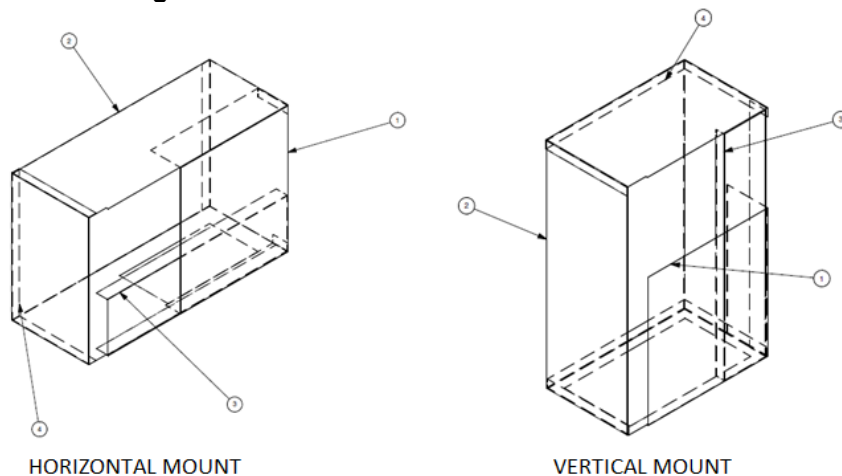

Section 9 – Hood, Fascia, and Covers

▪ **Horizontal Motor Cover Installation:**

1. Horizontal motor cover is designed to be fastened to the bracket using the welded on bracket clips and self-taping screws.
2. Pre-drill the holes after aligning cover pieces with the bracket clips to ease installation.
3. Install item 1 (back cover) from figure 9.5 Horizontal Cover to bracket at this time.
4. Place item 3 (side support) from figure 9.5 Horizontal Cover inside item 1 at the bottom so that it is flush with the edge furthest from the bracket and attach with self-taping screws.
5. At this time, attach the side support to the bracket clip with self-taping screws.
6. Place item 2 (front cover) from figure 9.5 Horizontal Cover over the assembly so that all pieces are inside and it aligns with the bracket and secure to the bracket clips with self-taping screws.
7. Secure front cover to the rest of the assembly with self-taping screws.
8. Place item 4 (side cover) from figure 9.5 Horizontal Cover over the open end of the assembly cover and secure with self-taping screws.

▪ **Vertical Motor Cover Installation**

1. Vertical motor cover is designed to be fastened to the bracket using the welded on bracket clips and self-taping screws.
2. Pre-drill the holes after aligning cover pieces with the bracket clips to ease installation.
3. Install item 1 (bottom cover) from figure 9.5 Vertical Cover to bracket at this time.
4. Place item 3 (side support) from figure 9.5 Vertical Cover inside item 1 at the side so that it is flush with the edge furthest from the bracket and attach with self-taping screws.
5. At this time, attach the side support to the bracket clip with self-taping screws.
6. Place item 2 (front cover) from figure 9.5 Vertical Cover over the assembly so that all pieces are inside and it aligns with the bracket and secure to the bracket clips with self-taping screws.
7. Secure front cover to the rest of the assembly with self-taping screws.
8. Place item 4 (top cover) from figure 9.5 Vertical Cover over the open end of the assembly cover and secure with self-taping screws.

Section 10 – Torque Specifications

Table 10.1 – Torque Recommendations for Guide Assembly and Wall Fasteners

Bolt size/type	Torque (ft-lbs) ^a
1/4-20 Grade 2 steel bolt	6
5/16-18 Black Oxide Socket Cap	25
3/8-16 18-8 stainless steel bolt	20
3/8-16 Grade 2 steel bolt	20
3/8-16 Grade 5 steel bolt	31
3/8-16 Grade 8 steel bolt	45
1/2-13 Grade 5 steel bolt	75
1/2-13 Grade 8 steel bolt	107
5/8-11 Grade 8 steel bolt	212
3/4-10 Grade 8 steel bolt	376

^a The recommended torque for steel bolts is based on a plated bolt that has not been lubricated.

Table 10.2 - Torque Recommendations for Solid Masonry Wall Anchors

Anchor Size (nominal)	Manufacturer/Torque (ft lbs) ^a	
	Redhead Trubolt	Hilti Kwik HUS-EZ
3/8	25	40
1/2	45	45
5/8	90	85
3/4	100	95

^a Torque values for grout filled block are different, reference bolt manufacturer for these values.

Section 11- Maintenance Schedule

▪ **Maintenance Schedule:**

Note: If any of the following problems exist, **do not** operate the door until repaired.

Component	What to look for and how often the components must be inspected:	Weekly	Monthly	Quarterly	What to do if problem exists:
Curtain & Bottom Bar	Are any curtain components damaged (slats, endlocks, etc.)?	X			Contact Service about replacing damaged parts.
	Is bottom bar damaged?	X			Contact Service about replacing damaged parts.
	Are bottom bar fasteners in place and properly tightened?		X		Fasteners must be inspected/replaced and properly tightened.
	Are fasteners attaching curtain to the barrel in place and properly tightened?		X		Fasteners must be inspected/replaced and properly tightened.
	Do you notice any hang-ups, jamming or other problems preventing the door from moving smoothly throughout the opening?	X			Check for external issues, if none exist, contact Service.
	Do you notice any odd or excessive noise when the door is operated?	X			Check for external issues, if none exist, contact Service.
	If there is a bottom seal, is it damaged?		X		Contact Service about replacing damaged parts.
	If there is locking, does it function properly?	X			Check for external issues, if none exist, contact Service.
Brackets	Are brackets plumb and perpendicular with wall?			X	Contact Service.
	Are bracket fasteners in place and properly tightened?			X	Fasteners must be inspected/replaced and properly tightened.
	Do you notice signs of excessive wear on the bearings (i.e. binding, excessive noise, etc.)?		X		If there is a grease fitting, apply grease, if not, contact Service.
Guides	Are wall fasteners in place and properly tightened?		X		Fasteners must be inspected/replaced and properly tightened.
	Are guide assembly fasteners in place and properly tightened?		X		Fasteners must be inspected/replaced and properly tightened.
	Is guide gap dimension correct?		X		Check job construction drawings and adjust gap as required. If job construction drawings are not available, contact Service.
	Are any of the guide parts bent or damaged?		X		Contact Service.
Hood and Fascia	Is hood/fascia dented or damaged?			X	Remove hood/fascia. Repair if possible. If not leave hood/fascia off and contact Service.
	Is curtain rubbing against the hood/fascia?	X			Hood/fascia may have been damaged. Contact Service.
	Is hood/fascia level?			X	Check fasteners, they may be loose or missing. Replace as soon as possible.
	Are guide assembly fasteners in place and properly tightened?		X		Fasteners must be inspected/replaced and properly tightened.
	Is hood support level?			X	Check fasteners, they may be loose or missing. Replace as soon as possible.
Door operation	Does the door require excessive force to open?		X		Check for hang-ups or obstructions. Contact Service.
	If the door contains locking, does the locking mechanism function properly and securely hold the door in the closed position?		X		Check for damage and other external issues. Contact Service.

Section 11- Maintenance Schedule

	Does the photoeye function properly?	X			Cut power and check for loose wires. Contact Service for further instruction.
	Does the light curtain function properly?	X			Cut power and check for loose wires. Contact Service for further instruction.
	If there is a sensing edge, does it function properly?	X			Cut power and check for loose wires. Contact Service for further instruction.
Motor Operator	Are the fasteners attaching the motor-to-the mounting bracket, and mounting bracket-to-the door bracket secure?			X	Fasteners must be inspected/replaced and properly tightened. Contact Service for replacement hardware.
	Is the door stopping correctly at the open and closed (as soon as the bottom bar contacts the floor) positions?		X		Limits may have to be adjusted in the motor operator. Refer to the operator owner's manual or contact Service.
	Is the operator functioning normally?		X		Refer to the <i>Operator Manual</i> to diagnose the problem.

Section 12- Curtain Repair

▪ **Assess the curtain damage:**

1. Locate and determine the sections of the curtain that are damaged (Rods, Links and Spacers).
 - a. Switch to constant pressure mode in the control panel and then bring the door to the fully closed position. Inspect the curtain attachment to the barrel for damage.
 - b. Coil the curtain up one revolution and inspect for damaged links and/or rods. Make note of sections that do not nest like shown in Figure 12.1. Continue to inspect entire curtain by coiling up one revolution at a time until door is in fully open position.

Figure 12.1 – Curtain Nesting

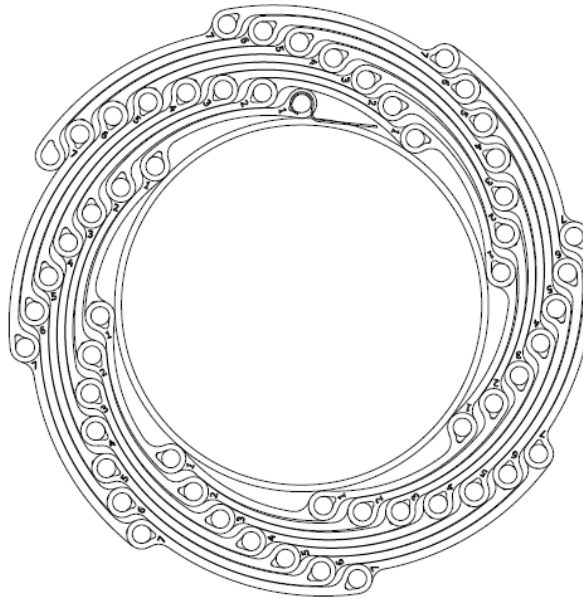

- c. Carefully inspect the section above and below the identified damage section. When a door is cycled with a damaged area, it's likely that the sections above and below the damaged area will be damaged as well.
 - d. Switch out of constant pressure mode, if the door is operable.
 - e. It's important to note that cycling with damaged links can cause more damage to other areas of the curtain.
 2. The sections can be determined by locating the link number on the side of the link as shown below. This information is necessary when contacting the service department for replacement of damaged sections.

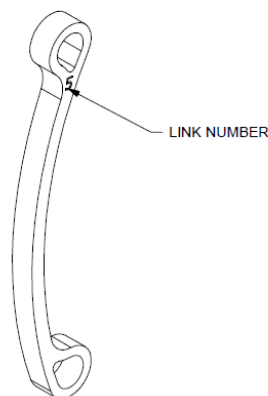

Section 12- Curtain Repair

▪ **Curtain Repair:**

1. Move door to the full open position, avoiding further damage to curtain.
2. Shut off power.
3. Engage hand chain by pulling on the red handle located at the bottom of the operator.
4. Loosely strap the coiled curtain to prevent bottom bar from dropping over backside in next steps.
5. Hand chain the door so the bottom bar is up and out of the guide assembly, in the 12 o'clock position. While doing this, be careful not to damage the bottom bar bumper flag.
6. Flip bottom bar over 180 degrees as shown below.
7. Continue to rotate coiled curtain until bottom bar goes over the top and is in the 3 o'clock position.

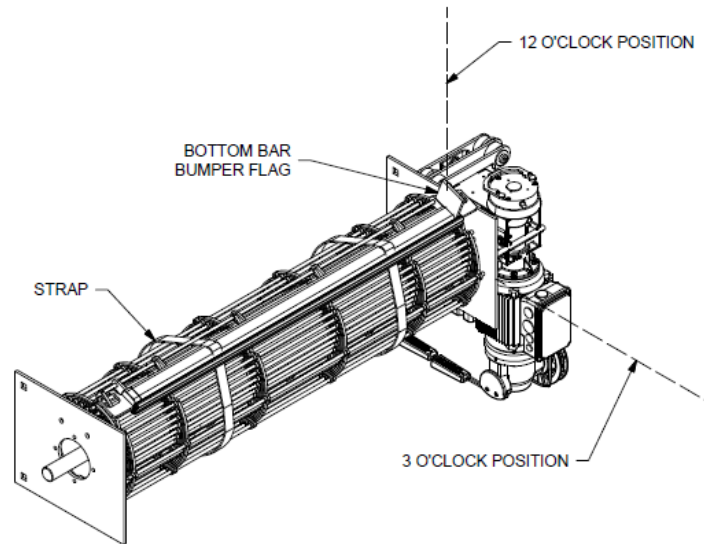

8. Remove straps at the 3 o'clock position and slowly lower the bottom bar by hand to its resting position.
9. Hand chain the curtain down, outside the guides, to a comfortable working height.
10. Identify the rod that will be removed. This can be done by locating the change of link number. It is important to note that per section, only 8 links of any one link type/number is used.

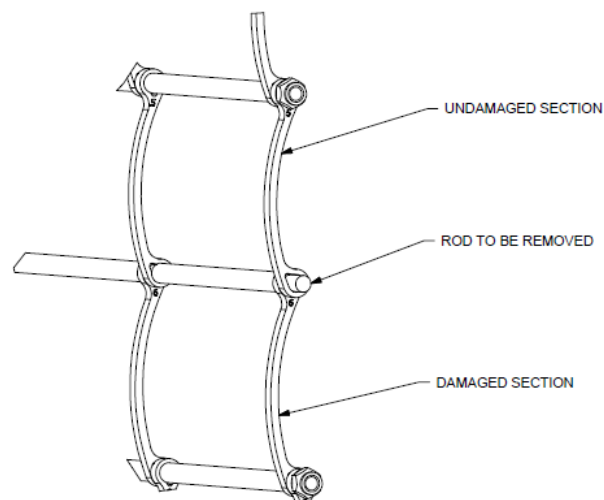

Section 12- Curtain Repair

11. Use zip ties as shown below to relieve curtain weight on the rod to be removed. This can also be achieved by using a strap over the shaft when the curtain section(s) are too heavy for zip ties.

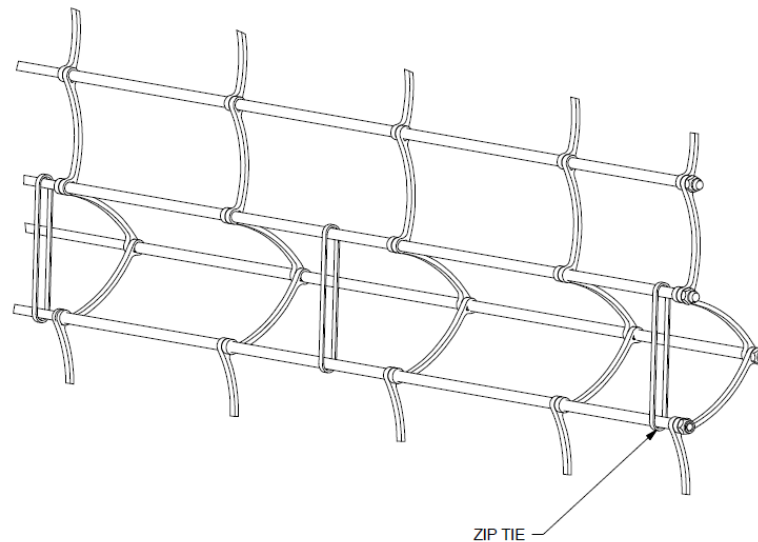

12. Remove the threaded nut on the rod ends.
13. Slide out the rod and remove the damaged section.
14. A new rod will be supplied with the replacement section. Use the new rod to attach the replacement section. Use zip ties to relieve curtain weight so rod will slide through links easily.
15. It's very important to maintain the link pattern when replacing a section by visually inspecting the replacement section to make sure it conforms to the existing pattern/orientation as shown in the figure below. This can be done by matching the orientation, link number location and curvature to links above and below the section being replaced.

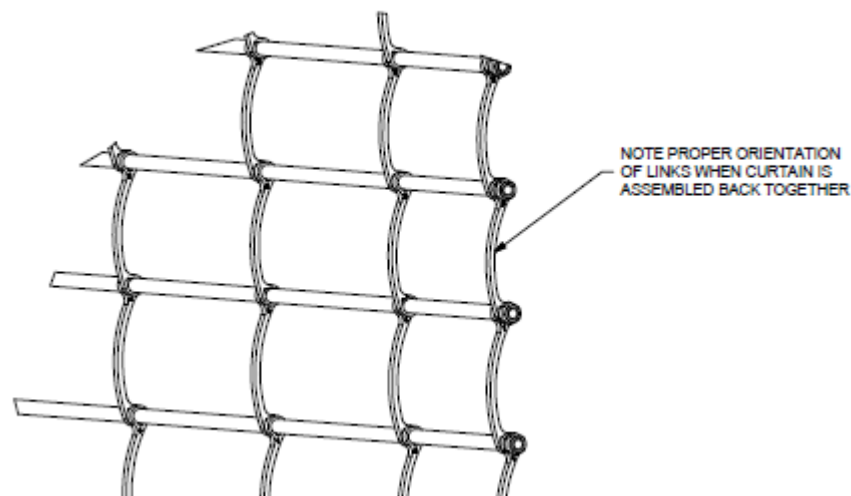

16. Install and tighten threaded nut on the rod ends and remove zip ties used in previous steps.
17. Hand chain curtain up to open position.
18. Lift bottom bar up, by hand, to 3 o'clock position and strap in place.
19. Perform steps in reverse order to get curtain back into guides and power up door.

Appendix A – Extreme® MicroCoil Grille Construction and Maintenance

- **Extreme® MicroCoil Grille Construction:**

- **Special Notes:**

1. The basic assembly sequence is as follows: guides, springless barrel w/ tapped holes, brackets (pre-assembled with bellmouths and inertia brake (if required)), motor operator, curtain, stoppers, weather stripping, hood, and operator/idler covers.
2. Prior to installing brackets onto the shaft, install the provided spacers onto the shaft.
3. Inertia brakes (if required) must be wired into operator interlock in case of failure.

Warranty Statement

CornellCookson warrants to the buyer that the Extreme MicroCoil grille will be free of defects in material and workmanship (ordinary wear and tear expected) for the time periods set forth below:

- **Mechanical** components for a period of **Two Years or 500,000 cycles**, whichever comes first, from the date of shipment.
- **Operator and Control panel** for a period of **Two Years or 500,000 cycles**, whichever comes first, from the date of Shipment.

This warranty does not include extra materials, equipment or labor that may be required due to site conditions, adjacent construction, incorrect installation, lack of maintenance, lack of access, ordinary wear, abuse or neglect. Documentation of a properly executed maintenance program will be required prior to corrective action being authorized. The design of coiling products by nature will abrade virtually any applied finish. For this reason, CornellCookson does not warrant either standard or optional finishes. Component wear is to be expected in the normal operation of a high cycle door. CornellCookson agrees to repair or replace, at CornellCookson's discretion, any parts which are determined, by CornellCookson, to be defective.

Job specific warranties, or warranties with obligations in addition to those listed above must be stated in writing and signed by CornellCookson.

PREVENTATIVE MAINTENANCE AND TEST PROCEDURES

These grilles have been designed for a minimum of maintenance. All scheduled maintenance and test procedures are to be found in this section.

Maintenance Schedule		
Cycles/Time (Whichever Occurs First)		
	Every 62,500/ 3 Months	Every 125,000/ 6 Months
Visual Inspection	INSPECT	INSPECT
Bracket Bearings	INSPECT	<u>LUBRICATE</u>
Drive Chain (if Required)	INSPECT	<u>LUBRICATE</u>
Limit Nuts/Shaft (If Required)	INSPECT	<u>LUBRICATE</u>
Motor Operator	INSPECT	INSPECT
Operator Brake Operation	TEST	TEST
Inertia Brake (If Required)	INSPECT	INSPECT
Sensing Edge (If Equipped)	TEST	TEST
Photoeyes/Light Curtain	TEST	TEST
Bellmouths	INSPECT	INSPECT
Guide Wear Strip	INSPECT	INSPECT

Maintenance Date								
Cycle Counter Readout								
Servicer Initials								

Appendix A – Extreme® MicroCoil Grille Construction and Maintenance

Comprehensive Maintenance

Item	Check
Visual Check	Visually inspect grille for unreported damage. Repair or replace any damaged parts. Visual inspection includes curtain, guides, hoods, and control panel.
Operational Check	Operate grille one full cycle while inspecting grille operation for binding, straining, or unusual noises. Correct any operational problems found.
Motor Check	Operate grille one full cycle while checking motor for unusual noises, smells, or smoke. Correct any motor operational problems found.
Drive Chain Lubrication/Inspection	Inspect roller chains, sprockets, and gears. Replace any sprockets or gears with teeth worn where they do not operate smoothly. Lubricate chains and gears with SAE approved gear oil. Adjust chain tension as required. Replace chain if stretched to point where it makes noise.
Safety Brake Inspection	Verify that red tab is not pushed out of housing. Operate grille one full cycle while checking for unusual noises and vibration. If red tab is pushed out or if unusual noises or vibrations are witnessed, Contact Service.
Limit Shaft/Nuts	Verify the threads on the limit shaft are not worn and are lubricated properly. Check for excessive shaft end play. Verify the limit nuts do not wobble excessively or bind on the limit shaft. Use SAE approved gear oil for lubrication.
Operator Inspection	Operate grille in the close direction and hit the “Stop” button when the bottom bar is about 36” above the finished floor. Verify that the brake does not allow the grille to continue to move in the closed direction more that 2” after the initial brake engagement.
Bracket Bearings	Inspect the bracket bearings for worn outer races and debris. Lubricate the bearings with bearing grease via the supplied grease fittings.
Sensing Edge	Operate the grille in the closing direction and contact the edge to verify edge functions and grille returns to the fully open position. Check the battery condition in the transmitter and replace battery if required. Inspect the bottom surfaces of the edge for cracking or separation at ends.
Photoeyes/Light Curtains	Operate the grille in the closing direction and place an obstruction in the path of the photoeyes as the grille is in mid-travel. Verify that the grille stops and reverses to the fully open position.