

# FIRE RATED COUNTER SHUTTER

Models ERC10, ERC11(SmokeShield), & ERC20 (integral frame and sill)



## PREPAREDNESS IS EVERYTHING WHEN SECONDS COUNT

### SUPERIOR SEPARATION AND PROTECTION

UL labeled for up to 3 hours, Fire-Rated Counter Shutters are custom-built to exact opening specifications using compact guides, slats, brackets and hoods for a smooth profile. When compact door components are desired, these rated shutters quickly and reliably close to the sill.

### GET UL LABELS FOR UP TO 1½ HOURS ON INTEGRAL FRAME AND SILL UNITS

For a custom appearance and a quick install, slip-in units easily set into existing walls.

### FAILSAFE ACTIVATION

AlarmGard® shutters may be integrated to the building fire alarm control panel or simply activated by local smoke detectors. Once notified by electrical signal, they close at a safe and reliable rate.

### ENHANCED SMOKE PROTECTION AVAILABLE

Optional SmokeShield® smoke and draft control conforms to UL1784 and ensures that smoke will be compartmentalized with the fire and not spread quickly throughout the facility, allowing safe egress for occupants.

**STANDARD COMPONENT MATERIALS AND FINISHES**

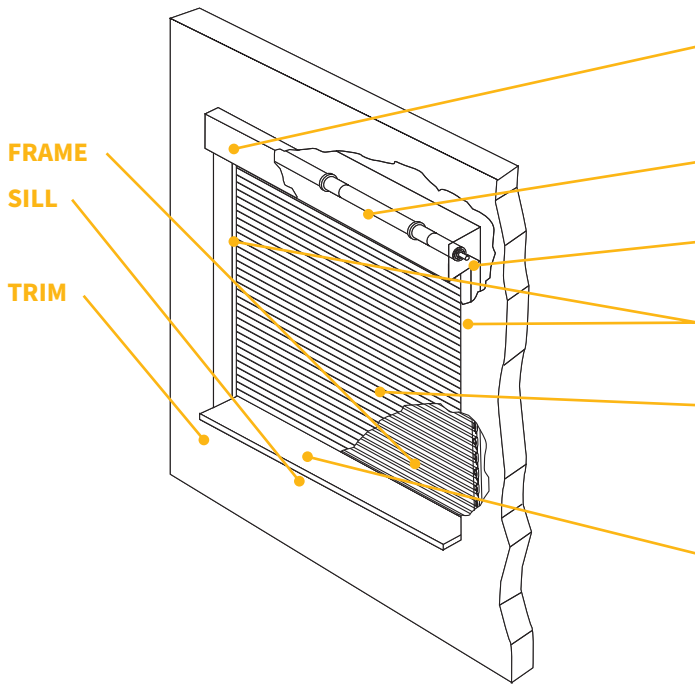

- HOOD** - Galvanized steel with GalvaNex™ polyester enamel finish to match curtain. Encloses the curtain and provides fire protection at the head of the door.
- COUNTER-BALANCE SHAFT** - Steel. Supports curtain and contains torsion springs for assisting operation.
- BRACKETS** - Steel with powder coating to match curtain. Bolt to guide assembly and support counter-balance shaft and curtain.
- GUIDES** - Steel with powder coating to match curtain. Guide assemblies bolt to the wall and support the entire weight of the unit.
- CURTAIN** - Galvanized steel with GalvaNex™ polyester enamel finish in Gray, Tan, or White. Interlocking roll-formed flat-faced slats with galvanized steel end locks riveted to the slats to maintain curtain alignment and prevent wear.
- BOTTOM BAR** - Steel with SpectraShield® powder coating to match curtain. Reinforcing member attached to the bottom of the curtain with a vinyl astragal seal. Locking mechanisms available.

**OPTIONAL MATERIALS AND FINISHES**

- ▶ Stainless steel - 300 series in #4 finish
- ▶ SpectraShield® Powder Coating in more than 180 colors
- ▶ For a more durable finish, consider upgrading to our Galvanex™ Ultra™ or SpectraShield® Ultra™ powder coat finish.
  - It is a polyester based textured wear resistant clear coat that provides increased resistance to corrosion of the curtain and improved durability against normal abrasion and scratching due to cycling.

**Brackets, Guides and Bottom Bar**

- ▶ Hot-dip galvanizing on steel components
- ▶ Zinc-enriched, corrosion-resistant powder coating in Gray

**WITH INTEGRAL FRAME AND SILL**

- HOOD** - Stainless steel.
- BRACKETS** - Stainless steel.
- CURTAIN** - Stainless steel.
- BOTTOM BAR** - Stainless steel.
- FRAME** - Welded stainless steel head and jambs. Guide groove is incorporated into jamb design.
- SILL** - Stainless steel provides a seamless, custom look.
- TRIM** - Stainless steel jamb trim angles. Head trim optional.

\*All stainless steel is 300 series in #4 finish

**OPERATION AND STRUCTURAL REQUIREMENTS**

**Hand-crank, push-up and a variety of motor options are available**

This product is supported by a guide assembly attached to the jamb construction. No additional header support is required unless hood supports are mandated by a larger opening width.



**CUSTOM-DESIGNED SOLUTIONS**

Contact our experienced Architectural Design Support Team for help in customizing our products to fit your specific application.

 [www.architectdoorhelp.com](http://www.architectdoorhelp.com)